

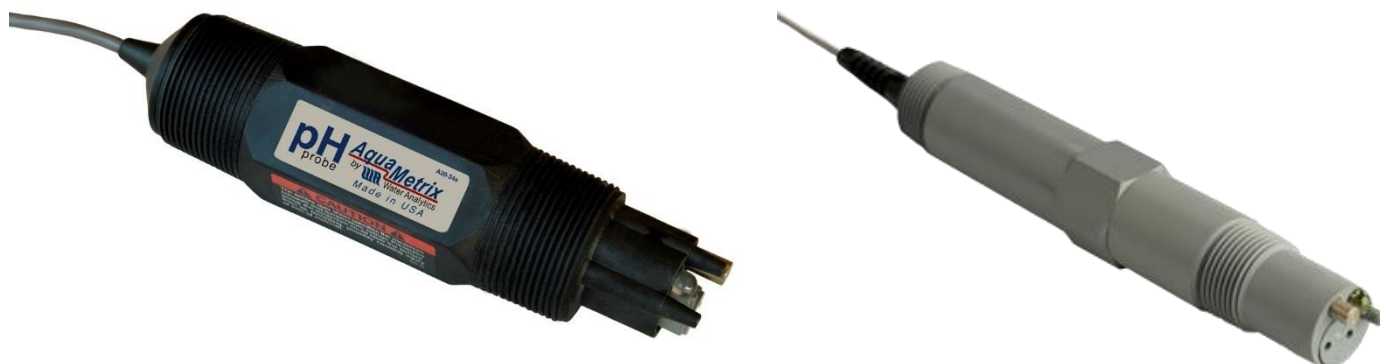

## OPERATING INSTRUCTION MANUAL



### 65-Series

### Differential 2-Wire (4-20 mA) pH & ORP Probes

N116-139 REV. 3

---

AquaMetrix, by Water Analytics Inc.  
100 School Street  
Andover, MA 01810

Tel: (978) 749-9949  
Toll Free: (855) PH-PROBE  
Fax: (978) 749-9961  
[www.AquaMetrix.com](http://www.AquaMetrix.com)

## TABLE OF CONTENTS

<b>1. GENERAL INFORMATION</b>	<b>3</b>
<b>2. SPECIFICATIONS</b>	<b>4</b>
<b>3. INSTALLATION</b>	<b>5</b>
3.1. GENERAL INSTRUCTIONS	5
3.2. CONNECTING TO A PLC OR AQUAMETRIX 2300 CONTROLLER	5
3.3. AVOIDING ISOLATION PROBLEMS	6
3.4. ORP (R65) SENSORS RANGE SELECTION	6
3.5. SUBMERSION MOUNTING FOR SERIES 8 AND 5 SENSORS	7
3.6. FLOW-THROUGH TEE MOUNTING FOR SERIES 8 AND 5 SENSORS	7
3.7. FLOW-THROUGH TEE MOUNTING SERIES 6 SENSORS	7
3.8. SANITARY PROBE SERIES 8 AND 5 SENSORS	8
3.9. HOT TAP (WET TAP) INSERTION MOUNTING SERIES 7 SENSORS	8
<b>4. CALIBRATION</b>	<b>8</b>
<b>5. TROUBLESHOOTING AND SERVICE</b>	<b>10</b>
5.1. CONNECTING A 65-SERIES SENSORS TO AN AMMETER	10
5.2. DIAGNOSING A P65 SERIES PH SENSOR	10
5.3. R65 SERIES ORP SENSORS	11
5.4. TEMPERATURE CHECK FOR PT65 AND RT65 PROBES	11
<b>6. SERVICE AND MAINTENANCE</b>	<b>11</b>
6.1. PROBE CLEANING	13
6.2. REPLACEMENT OF SALT BRIDGE	13
6.2.1. FOR SERIES 5, 6, 7 DIFFERENTIAL PROBES	13
6.2.2. FOR SERIES 8 DIFFERENTIAL PROBES	13
6.3. STORAGE	14
6.4. MAINTENANCE MESSAGES IN PLC (OPTIONAL)	14
7.1. TROUBLESHOOTING	15
7.2. CUSTOMER SERVICE	15
7.3. PARTS AND ACCESSORIES	16
<b>8. DRAWINGS</b>	<b>18</b>

## 1. GENERAL INFORMATION

This manual covers all AquaMetrix two-wire Series differential measurement pH and ORP probes.

The 65 series sensors feature the Aquametrix differential design for long lifetime, user serviceability and more accurate readings. In typical installations these probes will last for years whereas the more common combination probe lasts only months. The "P" prefix refers to the pH probe while the "R" prefix refers to the ORP version.

The 65 series sensor incorporates an encapsulated transmitter that outputs a 4-20 mA analog signal. It was designed to connect directly to a PLC or the AquaMetrix 2300 multi-input controller.

The PT65 and RT65 series sensors combine a separate temperature sensor with its own 4-20 mA transmitter. The PT sensors output a dual pH (or ORP) and temperature signal

The output from a two-wire transmitter type is non-isolated and un-calibrated. The system must provide 24 VDC, with the "low" input isolated from earth ground, and a means of calibrating for offset and span.

**NOTE:** Do not discard the protective cap(s) that came with the sensor. If the sensor is removed from the process for an extended period of time, thoroughly clean the sensor, put a piece of cotton ball with few drops of water into the protective cap and replace it on the sensor. This keeps the junction from drying out which causes slow response when put back into operation or causes permanent damage to the sensor. **Sensors should not be left in dry lines or empty tanks for extended periods.**

Do not store the sensors in a dry or humid location. When storing, check the protective cap(s) regularly to make sure the cotton ball remains moist. Improper storage of sensors voids the warranty.

## 2. Specifications

	pH P65-series	ORP R65-series
Measurement Range	0 to 14.00	User selectable: 0 to 1000 mV or -500 to +500 mV
PT and RT Versions	Temperature output range: 0 – 100 °C	
Wetted Materials	Ryton and/or CPVC, glass, ceramic, titanium, Viton	Ryton and/or CPVC, glass, ceramic, titanium, Viton, platinum or gold
Stability	0.03 pH/day	2 mV/day
Resolution	0.01 mA	± the greater of 0.1% of range or 2 mA
Sensitivity	< 0.005 pH	< 0.5 mV
Output Span	1.143 mA/pH	1.6 mA/100 mV
Output Offset	12±1 mA @ pH 7	0 to 1000 mV: 12±1 mA @ 500 -500 to 500 mV: 12±1 mA @ 0
Mounting	<ul style="list-style-type: none"> <li>- 5 sensor fixed 1.0" NPT insertion</li> <li>- 6 sensor variable insertion with 1.25" NPT</li> <li>- 7 sensor extended body for hot-tap application</li> <li>- 8 sensor fixed 1.5" NPT insertion</li> </ul>	
Flow Rate	3 m/sec (10 ft/sec). Flow should be as low as possible in water with low conductivity water or suspended solids	
Maximum Load	450 Ω	
Temperature Limits	-5 to 95°C (23 to 203°F)	
Pressure Limits	100 psig @ 65 °C, 40 psig @ 95°C	
Power Supply Limit	24±4 VDC, two 24±4 VDC for PT65 and RT65	
Probe Cable	15 ft. (4.6 m) standard. Up to 2000ft cable available.	
Transmission Distance	3000 ft (900 m)	
Temperature Compensation	Automatic for pH, none for ORP Isolated from Temperature Output in PT65 and RT65	

## 3. INSTALLATION

### 3.1. General Instructions

Specific instructions for each type of probe are given in the following pages. Common to all probes are the following instructions:

1. If the distance between the probe and the instrument is such that a direct connection is not possible, the probe cable should be routed to a junction box with a terminal strip (AquaMetrix Part No. AM-JB1). The box should be well sealed and away from corrosion danger. Be sure that you have sufficient slack cable to allow for probe removal for calibration and servicing.
2. Route the interconnect cable from the junction box to the instrument, preferably in metal conduit. Do not run the power cable or control cables in the same conduit with the probe interconnect cable.
3. Remove the protective plastic caps from the end of the probe before placing in service.
4. For best results probes should always be mounted vertically with electrodes down. If this is not possible, the probe must be at least 15° above horizontal.

### 3.2. Connecting to a PLC or AquaMetrix 2300 controller

P65 series sensors have two wires: Red – 24VDC Power, Black – Signal GND

R65 series sensors (purchased before 2017) have white and green wires in addition to the usual black and red ones. These wires are used to select the range and NOT to be terminated in any PLC inputs. See section 3.4.

PT65 and RT65 series sensors always have four wires:

1. Red – process 24VDC power
  2. Green – temperature 24VDC power
  3. Black – process signal
  4. White – temperature signal.
1. Refer to the top half of Figure 1 for configuring the probe for operation with a PLC. For connecting to a current sinking PLC or ammeter a separate 24 VDC power supply is needed. The wiring between the PLC and power supply is in series as shown on the top left side of the Figure 1.  
  
Most PLC's have powered, i.e. current sourcing, inputs that eliminate the need for an external power supply. The top right side of to Figure 1 shows the connections to the analog connector of a PLC.
  2. The AquaMetrix 2300 controller has both powered and unpowered inputs. The bottom left side of Figure 1 shows the connections of a probe to one of its four analog inputs and the 24 VDC power source.
  3. For connecting the PT65 to a PLC or 2300 the temperature wires (Green and White) follow the same pattern. Refer to the bottom right of Figure 1.

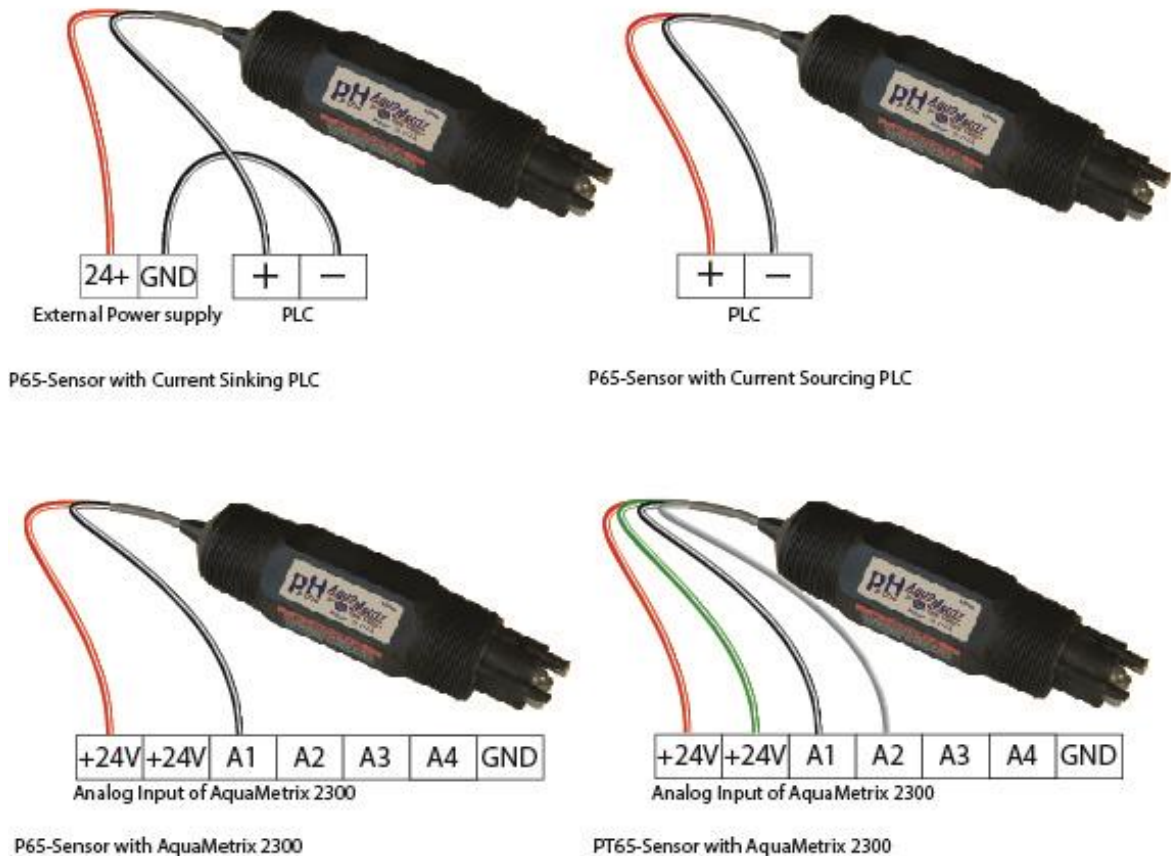

Figure 1 – Top left: Electrical connections for the 65 series sensors, with a 24 VDC power supply and a PLC. Top right: Electrical connections for the 65 series sensor with current sourcing PLC. Bottom left: Connections for a 65 series sensor with the AquaMetric 2300 controller. Bottom right: Connections for a PT65 with the AquaMetric 2300 controller.

### 3.3. Avoiding Isolation Problems

The 65-series is a loop-powered sensor, and, therefore, subject to issues caused by lack of isolation between it and other sensors or grounds. For instance when two sensors are connected to a PLC or 2300 the 24 VDC terminals (or ground for 3-wire sensors) are at the same potential. Any stray voltage that enters one of them will also enter the other. This includes changes in ground potential that result from the sample in which one probe is immersed not being grounded. Isolation issues (or lack thereof) can be some of the most difficult problems to solve. The symptom of a pH sensor that is held at ground is a constant signal at approximately 12 mA. For an ORP sensor and other sensors the output is held near 0 mA.

If one suspects that the process in which the probe is not isolated then an external power supply as shown in in Figure 1, can eliminate this problem. For the case in which a voltage change in one probe affects the output of another one can insert a galvanic isolator into between a sensor and the PLC or 2300.

### 3.4. ORP (R65) Sensors Range Selection

ORP R65 sensors purchased before 2017 have four wires; black, red, green and white. Do not connect the white and green wires to your PLC or 2300. By being open or shorted they enable the user to switch the range of the ORP sensor between -500 to +500 mV and 0 to 1000 mV.

1. To configure a sensor for a range of 0 to 1000 mV, connect (short) the green and white wires together.
2. To configure a sensor for a range of –500 to 500 mV, separate the green and white wires from each other.

ORP R65 sensors purchased after 2017 have a rocker switch for range selection. Figure 2 shows the switch.



Figure 2 - 2017 version of R65 series ORP sensors with rocker switch for range selection

### 3.5. Submersion Mounting for Series 8 and 5 Sensors

Refer to Figure 8-4.

1. A submersion mounting kit, AM-ARM-8 is available from Water Analytics which includes 4 ft. of pipe with a strain relief fitting and wire mounting bracket and a 1-1/2" NPT fitting. Proceed as follows, either with the kit or with your own hardware. For Series 5 sensors use AM-ARM-5 with 1" NPT fitting.
2. Route the sensor cable through an entire length of 1" pipe. A cable strain relief fitting should be used on the upper end of the pipe. Apply a thread sealant to the thread on the cable end of the probe and screw the probe into the fitting. The cable end of the probe should not be exposed to the process. In the kits a wire bracket is provided to aid in supporting the assembly.

**NOTE:** An optional protective shroud, Part No. AM-PTR-8 for 8 series (or AM-PTR-5 for 5 series) should be used on the electrode end of the probe to protect the electrodes from accidental contact with the tank bottom, sides or objects in the process.

### 3.6. Flow-through tee mounting for Series 8 and 5 Sensors

Refer to Figure 8-4.

1. Apply pipe sealant to the electrode end of the probe and screw it into the AquaMetrix union tee adaptor AM-TEE-8 for Series 8 sensors. (AM-TEE-5 for Series 5 Sensors)

### 3.7. Flow-through tee mounting Series 6 Sensors

Refer to Figure 8-2.

1. Take the compression fitting apart. Apply pipe sealant to the 1-1/4" NPT thread and screw this part into a 1-1/4" tee. A larger tee with an appropriate reducer may be used.
2. Put the compression fitting components on the probe in the order shown in the drawing. They should be in such a position that the electrodes will be in the pipe stream but not touching the opposite side of the tee.

3. Remove the protective cap from the probe and place the probe in the tee. Now tighten the nut by hand as much as possible, then turn 1/2 turn with a wrench.

### **3.8. Sanitary Probe Series 8 and 5 Sensors**

The 5 and 8 series sensors can be used with 2" sanitary fitting. Apply pipe sealant to the electrode end of the probe and screw it into the AquaMetrix sanitary flange (Part No. AM-SFL-5 or AM-SFL-8).

### **3.9. Hot Tap (Wet Tap) insertion mounting Series 7 Sensors**

Refer to Figure 8-3.

1. A ball valve assembly, AM-HTC-7, is available from AquaMetrix which includes the ball valve and safety shroud.
2. Mount the ball valve assembly in a desirable location. The assembly comes with a field selectable, 1-1/4 NPTF or socket adaptor. Make sure valve is in the close position before mounting.
3. Remove the union body by turning the union nut counter clockwise. Take the compression fitting apart as shown on the drawing. Insert the back end of the series 7 probe through the union body until safety notch on the probe aligns with the safety stop on the union body.
4. Place the union body, with the probe attached, back into the ball valve assembly and tighten union nut. Open ball valve & slide the probe into the process.
5. Put the compression fitting components on the probe in the order shown in the drawing and tighten the nut by hand as much as possible, then turn 1/2 turn with a wrench to keep probe in place.
6. Insert protective shroud as shown.

## **4. CALIBRATION**

All 65-series sensors are calibrated to output 4-20mA signal over the entire measuring range. The 65 series sensors have non-adjustable outputs.

Note that current output probes cannot be characterized by the same efficiency value as the "raw" 60 series probes. That's because the current output of the former is a function of the probe efficiency **plus** the transfer efficiency of probe voltage to current output.

Calibration for direct output probes is the process by which the current output of the probe is mapped to the value of the calibration solution in which the probe is immersed. This mapping is assumed to be linear so, typically, one calibrates using two points. Non-linear output in pH probes caused by alkaline error or acid error will result in a non-linear current response. In addition the mapping of probe voltage to current output always has some non-linear component. Some PLC's allow for calibration using more than two points. Under the assumption that the current output is approximately linear with process value the result of two-point calibration is a slope and offset.



Table 1 lists outputs for all standard calibration solutions for pH and ORP sensors and acceptable minimum values of the slope. These values are equal to 83% of the ideal slope. The acceptable offset for all probes is  $\pm 1$  mA. Every probe that leaves the factory must meet exceed the minimum slope stated in the table. Keep in mind that the minimum current outputs and maximum output of  $\pm 1$  mA are for new probes only. As probes age the output drifts. When the slope reaches approximately 75% of the ideal slope the probe should be replaced and set aside for emergency use.

**Note: Using the ideal current output values instead of performing an actual calibration can result in an error as high as 0.9 pH unit, 60 mV or 6 °C.**

Table 1 – Ideal current outputs of 65-series sensors. Single output probes include P65-X (pH) and R65-X (ORP). Double output probes include PT65-X (pH and temperature) and RT65-x (ORP and temperature). The acceptable deviation of output from these ideal values is  $\pm 1.0$  mA.

Output (mA)	pH	ORP (mV) -500 to + 500 mV	ORP (mV) 0 to 1000 mV	Temp. (°C)
4.00	0	-500	0	0
8.57	4			
7.20			200	20
12.00	7	0	500	50
13.60			600	
15.43	10			
20.00	14	500	1,000	100

Ideal Slope	1.143 mA/pH	0.016 mA/mV	0.16 mA/°C
Acceptable Slope (83%)	0.98 mA/pH	0.014 mA/mV	0.14 mA/°C
Acceptable Offset	$0 \pm 1$ mA		

Figure 3 graphically displays the range of acceptable output for P65 (pH) and PT65 (pH and temperature) probes. Figure 4 shows the range of acceptable output for R65 (ORP) and RT65 (ORP and temperature) probes. The dark blue band in the figures shows acceptable output for new 65-series sensors based on the 83% acceptance criterion. The wider light blue shaded band shows the acceptance for a 75% acceptance criteria of working probes.

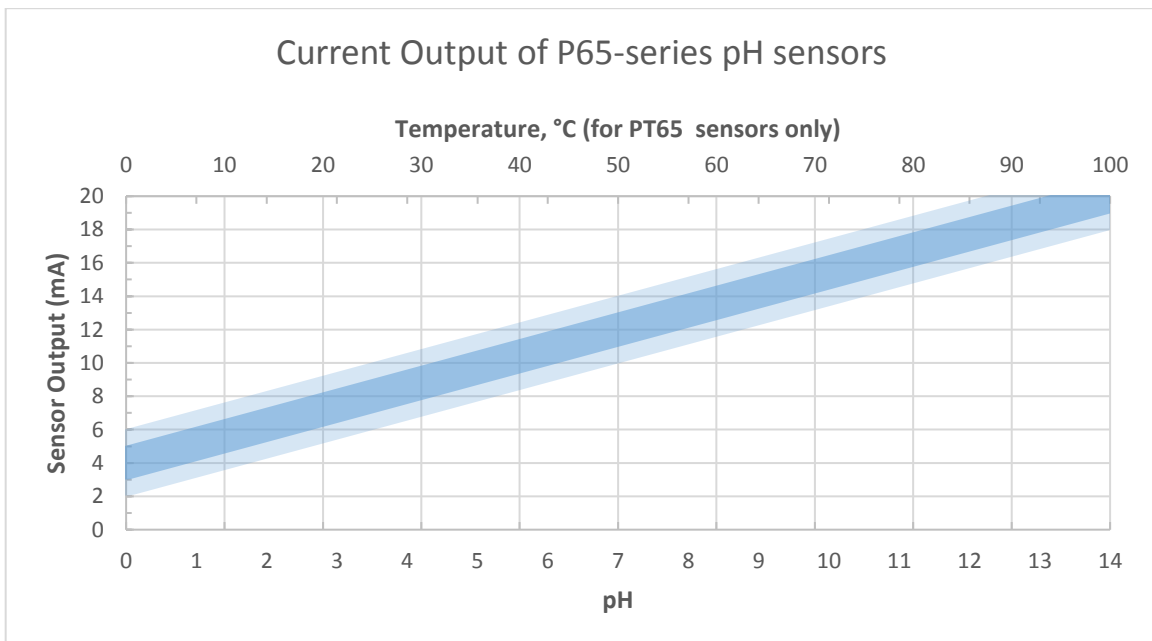

Figure 3 – Range of acceptable output for new P65 (pH) and PT65 (pH and temperature) probes. The dark blue middle band is for new probes and represents the acceptance criterion for new probes. The light blue outer band shows the acceptance criteria for working probes.

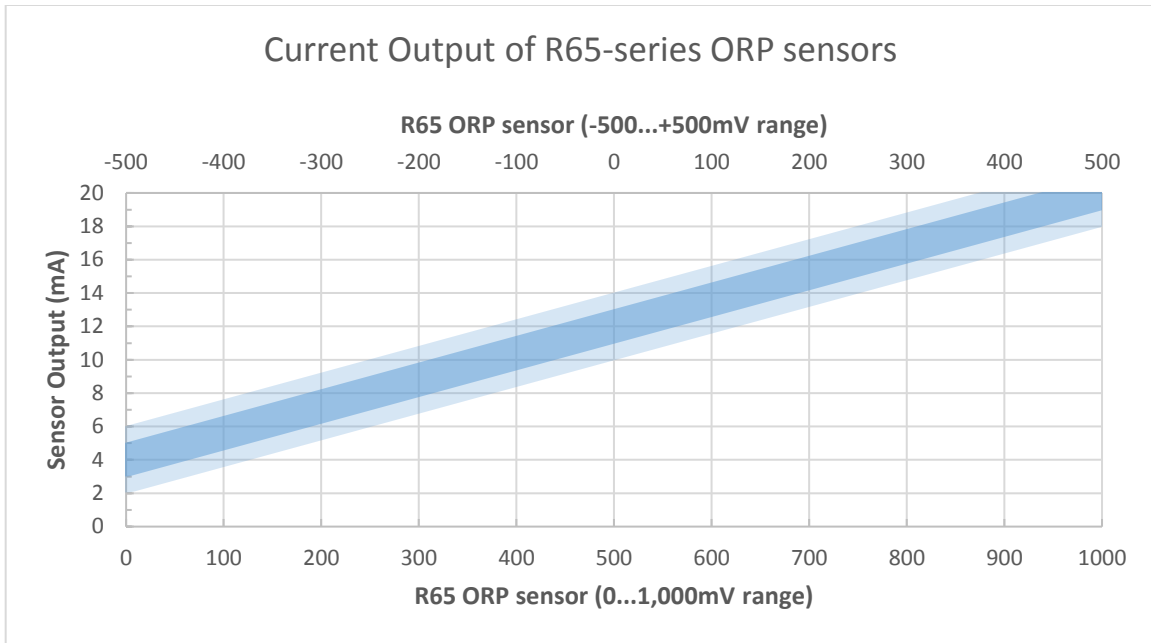
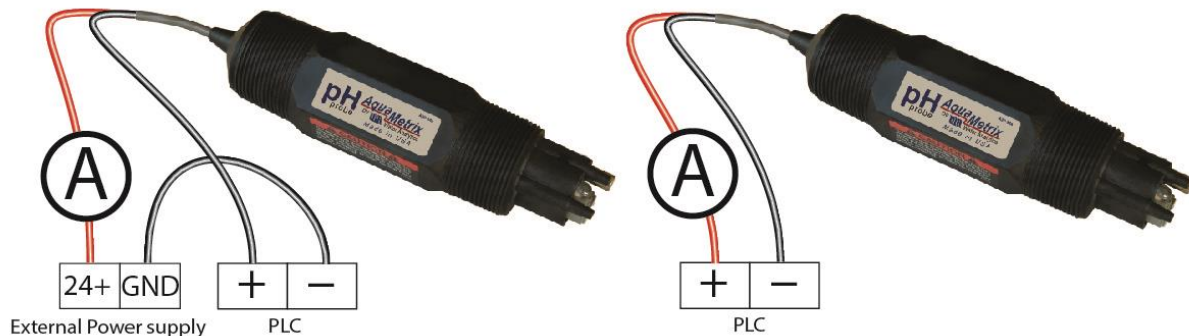

Figure 4 - Range of acceptable output for new R65 (ORP) probes. The dark blue middle band is for new probes and represents the acceptance criterion for new probes. The light blue outer band shows the acceptance criteria for working probes.

## 5. TROUBLESHOOTING AND SERVICE

### 5.1. Connecting a 65-series sensors to an ammeter

The 2300 and most PLC's can display a raw mA signal. If you are using a PLC that does not display the loop current then insert an ammeter as shown in Figure 5.



P65-Sensor with Current Sinking PLC

P65-Sensor with Current Sourcing PLC

Figure 5 – Connecting a PLC/2300 or an ammeter for sensor diagnostics.

### 5.2. Diagnosing a P65 series pH sensor

1. Rinse the probe and place it in pH 7 buffer. Allow the temperature of the buffer and probe to stabilize at room temperature.

2. Note the current reading for pH 7. This is the offset of the probe. The reading should be between 11 and 13 mA. If it is not then the probe needs maintenance or is defective. If the offset is within these limits then note the exact reading and proceed to the next step.
3. Rinse the probe and place it in pH 4 or pH 10 buffer. Allow the current of the probe to stabilize. Check the span of the probe by reading the ammeter. If the probe is in pH 4 buffer, the reading should be between 2.85 and 3.99 mA lower (pH 4) or higher (pH 10) than the reading obtained in pH 7. A perfect reading is 3.43 mA and one can assign an efficiency rating to the probe by dividing the actual span by 3.43. (Note that this is not the same as efficiency of a pH probe, which takes into account only the voltage output of the probe with pH.)
4. If the span of the probe drops below 2.85 mA then the efficiency is less than 83%. The probe still can be used with proper calibration but its accuracy will be compromised. If the output is less than 2.23 mA the probe should be replaced.
5. To check the operation of the temperature compensation in the probe, heat the buffer to about 50°C. The ammeter reading should be within  $\pm 0.2$  mA of the reading observed in the same buffer at room temperature. This tolerance is approximate as different buffers exhibit pH values that differ with temperature.

### 5.3. R65 series ORP sensors

1. Set the probe range to 0 to 1000 mV. For probes made in 2017 or later switch in position set the position of the switch to 0-1000mV, For older probes short the white and green wires together.
2. Rinse the probe and place it in the 200 mV solution. The ammeter should read between 6.2 and 8.2 mA.
3. Rinse the probe and place it in the 600 mV solution. The meter should read 6.4  $\pm$ 0.6mA higher than the reading obtained in ORP 200mV solution.
4. As explained for pH probes, a smaller difference can still enable the probe to be used with calibration.

### 5.4. Temperature check for PT65 and RT65 Probes

1. Insert the probe into a mixture of ice and water. The meter should read between 3 and 5 mA.
2. Insert the probe into a sample of water at 50 °C. The meter should read between 11 and 13 mA.

## 6. SERVICE AND MAINTENANCE

There are three sensor components that require routine maintenance:

1. **Process electrode.** The process electrode of a pH probe is pH-sensitive glass whereas the process electrode of an ORP probe is a platinum or gold band wrapped around a plain glass envelope. Both need to be kept clean, which usually means free of biofilms and/or scaling.
2. **Reference Solution.** The reference solution in either a pH or ORP probe is typically pH 7 buffer. As the probe ages reference solution flows out of the salt bridge while the process flow into the junction and into the reference chamber. The result is a steady contamination of reference solution. The pH trends toward 7 as the reference solution more closely resembles the process.
3. **Salt Bridge.** The salt bridge will foul over time through the accumulation of suspended solids and organic matter. The result is that the probe responds increasingly sluggishly and erratically.

The frequency of maintenance depends strongly on the application. Probes in clean water can go for months without the need for cleaning and recalibration but only two weeks in a metal plating

operation. Fortunately, by calibrating on a regular basis, one can determine when maintenance is due. The following rules of thumb are useful.

1. If calibration shows a pattern of decreasing span then the probe needs to be cleaned. This is why it is important to record the efficiency at every calibration. Probes that leave the factory have an efficiency of at least 83%. Probes in service can have a span as low as 50% and still be usable though their accuracy will diminish as the span drops. In general, a probe with a span less than 65% should be replaced and set aside for emergency use. A probe with a span less than 50% should be discarded.

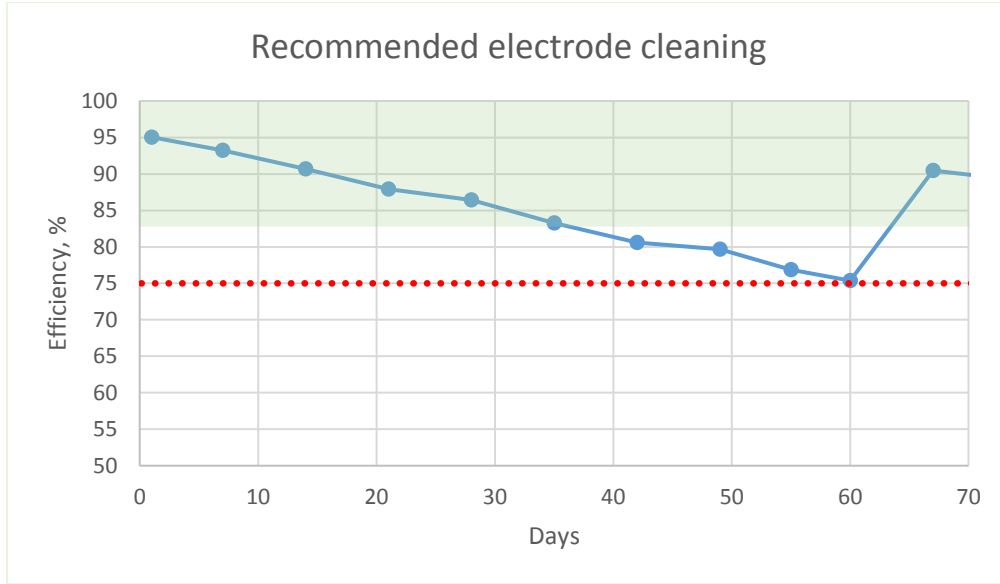

Figure 6 – Efficiency before and after electrode cleaning.

2. If the calibration shows a pattern of increasing offset, then the reference solution needs to be replaced. An offset greater than 2 mA indicates need of replacing salt bridge.

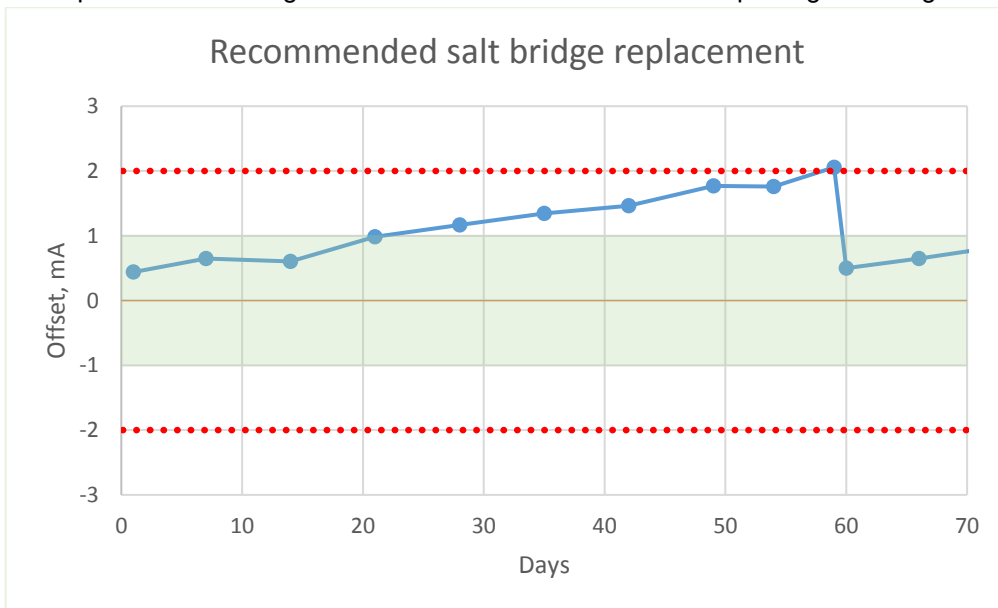

Figure 7 - Offset improvement after replacement of salt bridge.

3. If the probe takes more than about 15 seconds to fully respond to a change in pH then the salt bridge should be replaced. Of course that also requires replenishing the reference solution.

## 6.1. Probe Cleaning

1. Rinse the probe and use a soft brush, e.g. a soft toothbrush, and detergent to gently remove loose debris. Be careful: *The process electrode of a pH probe is comprised of very thin glass and breaks easily. Breaking it is the death of the probe.*
2. Rinse with clean warm water. Tap water is fine.
3. For scaling (calcium carbonate deposits) soak the probe in a weak acid for about an hour. White vinegar works great. Hydrochloric or sulfuric acid diluted ten-fold will do the job in about 10 minutes.
4. For biofilm fouling soak the probe in bleach for about 20 minutes.
5. Rinse the probe again in water.
6. Calibrate the probe in accordance with the instrument instruction manual.

## 6.2. Replacement of Salt Bridge

### 6.2.1. For Series 5, 6, 7 Differential Probes

Refer to Figure 8-5 - Installation of salt bridge in a differential probe. The probe pictured is a series 6 or 7 probe. For a series 8 probe a hex driver is used to remove and install the salt bridge. Figure 8-5

1. If the system cannot be calibrated after cleaning the probe, it may be necessary to replace the reference solution. A kit is available from Water Analytics for this purpose (Part No. AM-SBK-567). Proceed as follows:
2. Hold the probe vertically with the sensor face up. Insert long nose pliers in the blind holes in the salt bridge and turn counter-clockwise taking care not to damage the glass electrode. Discard the used salt bridge.
3. Up-end the probe and pour out the contents of the standard electrode chamber. Flush the chamber with a small amount of pH 7 buffer or clean water.
4. Refill the chamber with 7pH buffer solution up to the tip of the electrode inside the chamber. DO NOT OVERFILL. It is important to leave space for the salt bridge thread and a small amount of air.
5. Screw the new salt bridge into the cavity until finger tight. Now turn 1/4 turn with long nose pliers. The front face of the salt bridge should be flush with the probe face.

### 6.2.2. For Series 8 Differential Probes

1. If the system can't be calibrated after cleaning the probe, it may be necessary to replace the standard cell solution and/or the salt bridge. A salt bridge kit is available from Water Analytics for this purpose (Part No. AM-SBK-8). Proceed as follows:
2. Hold the probe vertically electrodes up. Remove the used salt bridge. For the -8 probe the salt bridge is a hexagonal-shaped capsule that can be removed using a 9/16" socket wrench. Discard the used salt bridge.
3. Dispose of the used solution inside the bridge chamber and flush with pH 7 solution or distilled water.
4. Refill the chamber with 7pH buffer solution, up to the tip of the electrode, inside the chamber. DO NOT OVERFILL. It is important to leave space for the salt bridge thread and a small amount of air.
5. Screw the new salt bridge into the cavity until finger tight. Now perform a 1/4 turn with a 9/16" socket wrench. The salt bridge edges should be flush with the front of the probe face.

### 6.3. Storage

1. Do not discard the protective cap(s) that came with the sensor. If the sensor is removed from the process for an extended period of time, thoroughly clean the sensor, put a piece of cotton ball with few drops of water into the protective cap and replace it on the sensor. This keeps the junction from drying out which causes slow response when put back into operation or causes permanent damage to the sensor. **Sensors should not be left in dry lines or empty tanks for extended periods.**
2. Do not store the sensors in a dry or humid location. When storing, check the protective cap(s) regularly to make sure the cotton ball remains moist. Improper storage of sensors voids the warranty.

### 6.4. Maintenance messages in PLC (optional)

For advanced users, PLC can be trained to predict maintenance and display messages for operators.

A calibration log, as shown in Table 2, can be incorporated in PLC logic. Once continuing loss of efficiency noted (see weeks 1-5) and/or efficiency falling below the threshold of 75% - there could be a popup message about an immediate need of cleaning glass electrode and recalibration. If efficiency of the sensor remains in >80% range and the gradually increases (by more than 2mA) – the message should ask to replace the salt bridge and recalibrate.

Table 2 - Weekly Calibration Log for pH sensor

	pH7, mA	pH4 (or pH10), mA	Slope, mA/pH	Offset	Efficiency
Initial Calibration	12.04	8.78	1.09	0.43	95%
1 WEEK Calibration	12.14	8.92	1.07	0.63	94%
2 WEEK Calibration	11.99	8.87	1.04	0.71	91%
3 WEEK Calibration	11.58	8.70	0.96	0.86	84%
4 WEEK Calibration	11.33	8.59	0.91	0.94	80%
5 WEEK Calibration	10.89	8.35	0.85	0.96	74%
After Cleaning	12.36	9.24	1.04	1.08	91%
6 WEEK Calibration	12.31	9.26	1.02	1.19	89%
7 WEEK Calibration	12.12	9.21	0.97	1.33	85%
8 WEEK Calibration	12.12	9.24	0.96	1.40	84%
9 WEEK Calibration	12.36	9.51	0.95	1.71	83%
10 WEEK Calibration	12.59	9.81	0.93	2.10	81%
Replaced Salt Bridge	11.25	8.34	0.97	0.46	85%

$$\text{Slope} = \frac{\text{mA@pH7} - \text{mA@pH4}}{\Delta\text{pH}}$$

$$\text{Offset} = \text{mA@pH7} - (\text{slope} * 7) - 4$$

$$\text{Efficiency} = \frac{\text{Measured Slope}}{\text{Ideal Slope}}$$

## 7.1. Troubleshooting

A pH or ORP probe is a simple instrument. As a potentiometric device, it outputs a voltage in response to a change in pH or ORP. The built-in transmitter converts the voltage to a current. A probe that is not functioning properly will output a current that is out of range of the specifications listed in Section 5.1

The change in output with calibration standard constitutes the span.

For a pH probe: The span between pH 4 and pH 7 or between pH 7 and pH 10 should be between 2.85 and 3.99 mA.

The ORP sensor is unique in that the voltage is the ORP reading. There is no span between readings of two calibration solutions. However, mA readings should be within the ranges stated in Section 5.1.

If the span of a pH probe or the absolute mA readings of an ORP probe do not satisfy these criteria then the cause of the problem may be one of the following:

1. The process electrode is coated with scaling or biofouling.
2. The process electrode is inoperable (likely broken).
3. The reference solution has been contaminated with the process to the point that it is no longer pH 7.
4. The salt bridge has fouled to the point that reference solution cannot pass through that is needed to complete the potentiometric circuit.
5. The printed circuit board (PCB) has shorted out by ingress or the op-amp on the board has failed.

The manifestations of these different sources are as follows:

1. A coated electrode (1) will create a narrower span or reduced ORP readings. If the coating is from scaling, then soaking the probe in a weak acid (e.g. vinegar or 0.1M HCl) will remove the scale. If the coating is from fouling, then soaking the probe in bleach will clear it.
2. Either problems 2 or 5 If the pH or ORP reading does not change when changing from one calibration solution to another then either the cause is a failed PCB (5) or broken electrode (2).
3. A contaminate reference solution (3) will result in both a lower span and higher offset for pH probes or an erroneous ORP reading.
4. A fouled salt bridge (4) will result in a slower response but not necessarily a narrower span or inaccurate ORP readings. AquaMetrix sells replacement salt bridges at very modest pricing.

## 7.2. Customer Service

If a problem has not been resolved with the above procedures, a telephone consultation with your AquaMetrix representative, or directly with Water Analytics will provide the answer.

978-749-9949

[www.AquaMetrix.com](http://www.AquaMetrix.com)

[support@WaterAnalytics.net](mailto:support@WaterAnalytics.net)

If you are returning a probe for inspection, enclose description of the problem. Pack the probe adequately to avoid damage to the glass electrode and ensure that it will not be exposed to temperatures below  $-5^{\circ}\text{C}$ . Water Analytics cannot be responsible for shipping damage nor for damage due to frozen electrodes. For safety reasons, Water Analytics cannot accept probes which have not been thoroughly cleaned to remove all process material.



### 7.3. Parts and Accessories

Description	Old Part #	New Part#
Submersion Mounting Kit for Series –8 Probes	STC60L	AM-ARM-8
Submersion Mounting Kit for Series –5 Probes		AM-ARM-5
Protective shroud for Series –8 Probes	PROTECTOR-3	AM-PTR-8
Protective shroud for Series –5 Probes		AM-PTR-5
Hot/Wet tap Ball Valve Assembly for Series –7	P60-HTC	AM-HTC-7
Union Mounting Tee w/ Adaptor for Series –8	AM-MH538N9A	AM-TEE-8
500 mL pH 7 Buffer Solution	A35-14	AM-PH7-05
4L pH 7 Buffer Solution	A35-118	AM-PH7-40
500 mL pH 4 Buffer Solution	A35-13	AM-PH4-05
4L pH 4 Buffer Solution	A35-117	AM-PH4-40
500 mL pH 10 Buffer Solution	A35-24	AM-PH10-05
4L pH 10 Buffer Solution	A35-119	AM-PH10-40
500 mL 200mV Buffer Solution	A35-40	AM-R20-05
4L 200mV Buffer Solution	A35-115	AM-R20-40
500 mL 600mV Buffer Solution	A35-41	AM-R60-05
4L 600mV Buffer Solution	A35-116	AM-R60-40
Salt bridge kit for Series –4, –6, –7 & –S (Package of 3 salt bridges and cell solutions)	C35-17(K)	AM-SBK-567
Salt bridge kit for Series –8 (Package of 3 salt bridges and cell solutions)	AM60-9765(K)	AM-SBK-8
Junction box with terminal strip	JB-1	AM-JB1
2-wire Interconnect cable for P65 and R65	C42-1-xxx	AM-CBL-65-xxx
4-wire Interconnect cable for PT65 and RT65		AM-CBL-AS-xxx

## Probe and Accessory Photographs

<p>P65R8-015 R65R8-015 PT65R8-015 RT65R8-015</p>		<p>P65C5-015 R65C5-015</p>	
<p>P65C6-015 R65C6-015</p>		<p>P65C7-015 R65C7-015</p>	
<p>2" Sanitary Flange -8: AM-SFL-8 -5: AM-SFL-5</p>		<p>Union Tee with adapter  -8: AM-TEE-8 -5: AM-TEE-5</p>	
<p>Protectors -8: AM-PTR-8 -5: AM-PTR-5</p>		<p>Jet Cleaners -8: AM-JET-8 -5: AM-JET-5</p>	
<p>Salt Bridge Kit -8: AM-SBK-8</p>		<p>Salt Bridge Kit -5: AM-SBK-567 -6: AM-SBK-567 -7: AM-SBK-567</p>	
<p>Hot Tap Assembly AM-HTC-7</p>		<p>Submersion Hardware -8: AM-ARM-8 -5: AM-ARM-5</p>	
<p>Junction box AM-JB1</p>		<p>Interconnect cable: P65: AM-CBL-65 PT65: AM-CBL-AS</p>	
<p>pH Calibration Solutions (500ml) pH4: AM-PH4-05 pH7: AM-PH7-05 pH10: AM-PH10-05</p>		<p>ORP Calibration Solutions (500ml) 200 mV: AM-R20-05 600 mV: AM-R60-05</p>	

## 8. DRAWINGS

  
**Differential pH/ORP Probe Series**  
**(P/r-60/65-X) Dimensions**

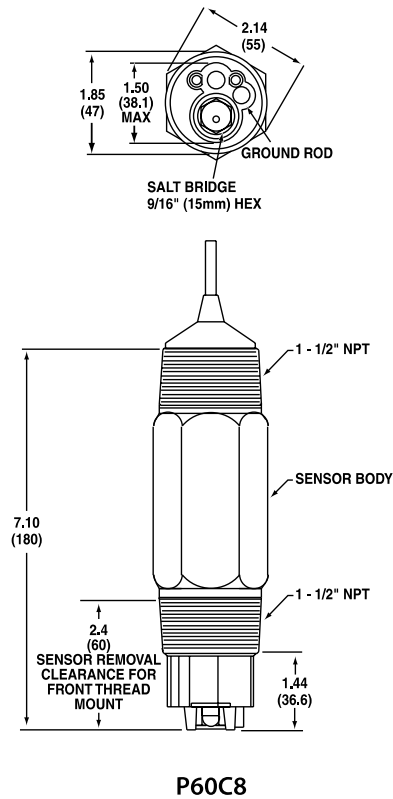

N106-279

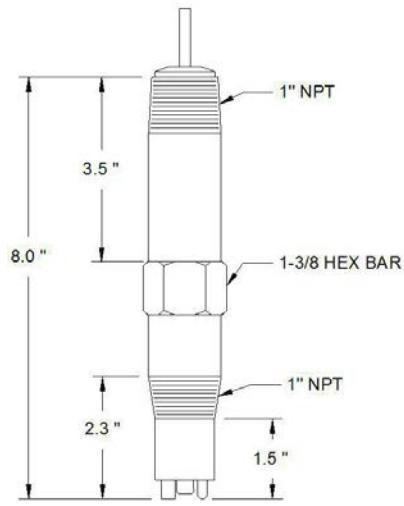

**P60C5**



**P60C6**

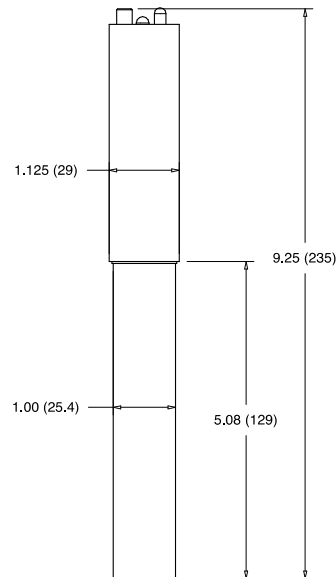

**P60C7**

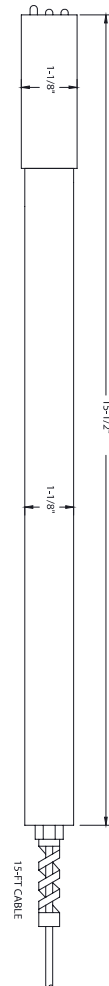
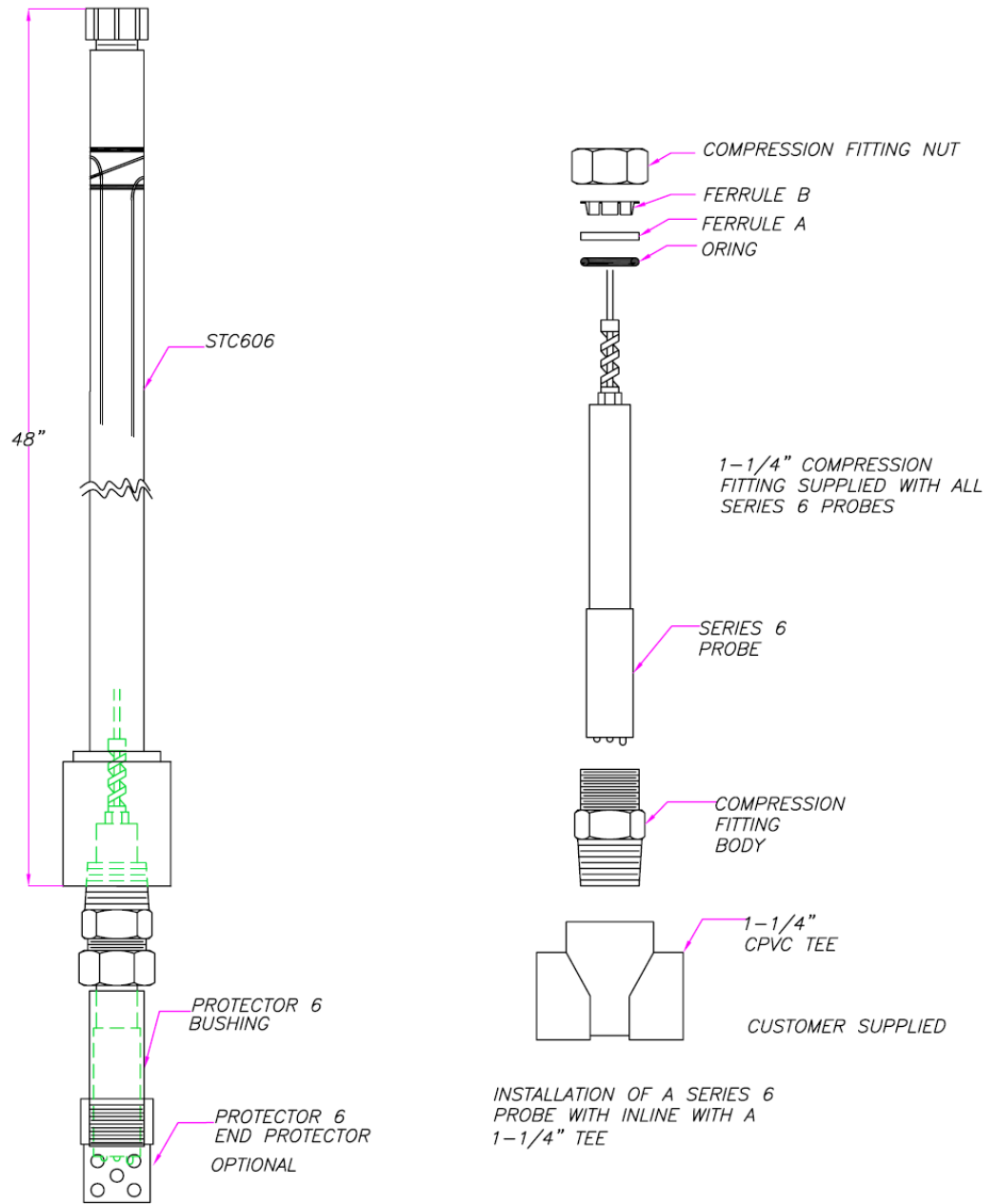

Figure 8-1 - Dimensions of -5, -6, -7 and -8 probes.

REVISIONS			
SYM	DESCRIPTION	DATE	APPROVAL
1	ORIGINAL ISSUE	26JAN05	P.MCLEAN



INSTALLATION OF A SERIES 6 PROBE WITH STC606 AND PROTECTOR 6 HARDWARE

<b>AquaMetrix Inc.</b> Industrial and Environmental Controls			
<b>INSTALLATION OF SERIES 6 DIFFERENTIAL PROBES</b>			
DRWBY: P.MCLEAN	BY: P.MCLEAN	DATE: 26JAN05	REV: 1
CHKD: P.MCLEAN	APPD: P.MCLEAN	SCALE: NTS	SHEET 01 OF 01
CODE IDENT NO.:	SIZE: A	AQUAMETRIX DRAWING NO.:	N105-73

THE INFORMATION ON THIS DRAWING IS PROPERTY OF AQUAMETRIX INC. AND MUST NOT BE REPRODUCED OR TRANSMITTED IN ANY FORM OR BY ANY MEANS, ELECTRONIC OR MECHANICAL, INCLUDING PHOTOCOPYING, RECORDING, OR BY ANY INFORMATION STORAGE AND RETRIEVAL SYSTEM, WITHOUT THE WRITTEN PERMISSION OF THE COMPANY AND MUST NOT BE USED IN ANYWAY DETRIMENTAL TO THE INTEREST OF AQUAMETRIX INC.

Figure 8-2 - Installation of a series 6 differential probe.

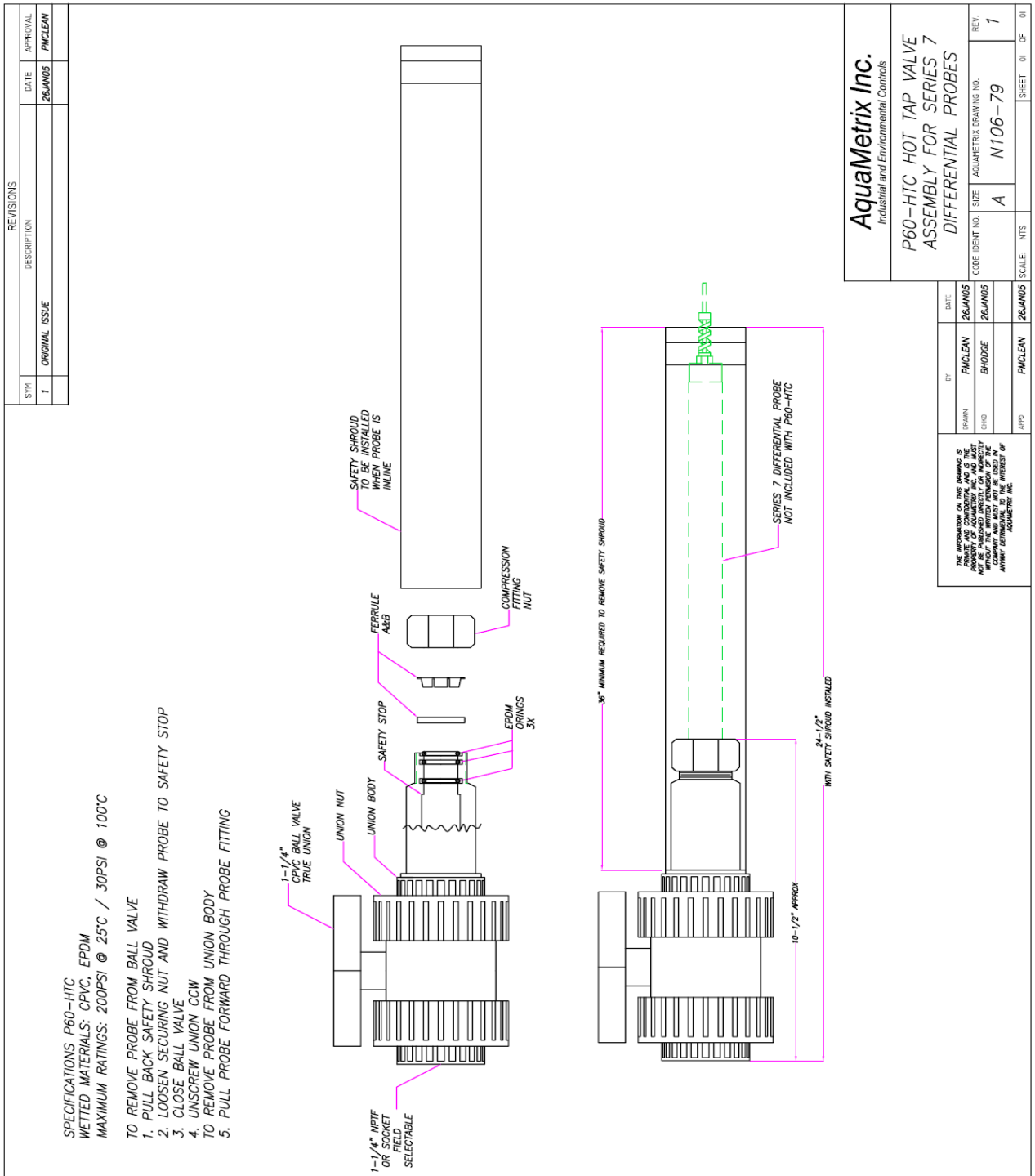

Figure 8-3 - Installation of a series 7 differential probe.

**AquaMetrix Inc.**  
Industrial and Environmental Controls

**P60-HTC HOT TAP VALVE ASSEMBLY FOR SERIES 7 DIFFERENTIAL PROBES**

DRAWN	DATE	CAGE IDENT NO.	SIZE	AQUAMETRIX DRAWING NO.	REV.
PACLEAN	26JAN05	A	N106-79	1	1
CHKD	26JAN05			SCALE:	NTS
APPD	PACLEAN			SHEET	01 OF 01

THE INFORMATION ON THIS DRAWING IS THE PROPERTY OF AQUAMETRIX INC. AND IS TO BE USED ONLY FOR THE PROJECT AND CONDITIONS AND TO THE EXCLUSIVE USE OF THE CLIENT. IT IS NOT TO BE REPRODUCED, COPIED, OR TRANSMITTED IN ANY FORM OR BY ANY MEANS, WITHOUT THE WRITTEN PERMISSION OF AQUAMETRIX INC.

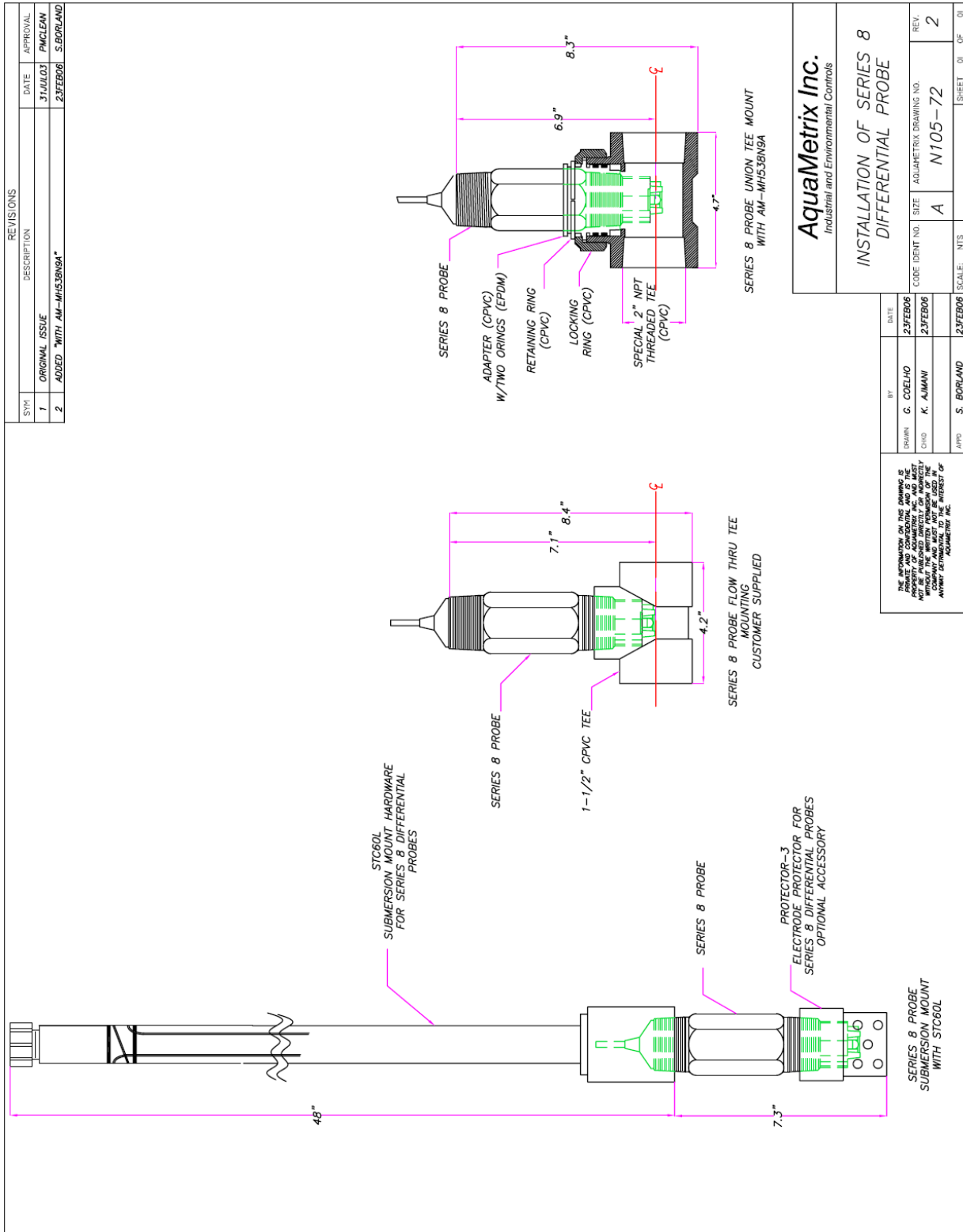

REVISIONS		
SYM	DESCRIPTION	DATE
1	ORIGINAL ISSUE	31 JUL 03
2	ADDED "WITH AM-MH5389A"	23 FEB 06

APPROVAL	
DATE	APPROVAL
31 JUL 03	PMCLEAN
23 FEB 06	S.BORLAND

**AquaMetrix Inc.**  
Industrial and Environmental Controls

**INSTALLATION OF SERIES 8 DIFFERENTIAL PROBE**

CODE IDENT NO.	SIZE	AQUAMETRIX DRAWING NO.	REV.
A	N105-72		2

DATE	BY
23 FEB 06	G. COELHO
23 FEB 06	K. AJMANI

DATE	BY
23 FEB 06	G. COELHO
23 FEB 06	K. AJMANI

THE INFORMATION ON THIS DRAWING IS THE PROPERTY OF AQUAMETRIX INC. AND MUST BE KEPT IN CONFIDENTIALITY. NO PART OF THIS DRAWING IS TO BE REPRODUCED OR TRANSMITTED IN ANY FORM OR BY ANY MEANS, WITHOUT THE WRITTEN PERMISSION OF AQUAMETRIX INC. IN THE INTEREST OF THE CUSTOMER.

APPROVED	S. BORLAND	23 FEB 06	SCALE: NTS
----------	------------	-----------	------------

SHEET 01 OF 01

Figure 8-4 - Installation of a series 8 differential probe. For a series 5 probe the hardware is the same with the exception of the thread sizes of the tee, protector and submersion arm.