

OneWireless
XYR 6000 Transmitters
Quick Start Guide

34-XY-25-21
Revision 12
February 2013

Notices and Trademarks

**Copyright 2008 by Honeywell International Inc.
Revision 12, February 2013**

While this information is presented in good faith and believed to be accurate, Honeywell disclaims the implied warranties of merchantability and fitness for a particular purpose and makes no express warranties except as may be stated in its written agreement with and for its customers.

In no event is Honeywell liable to anyone for any indirect, special or consequential damages. The information and specifications in this document are subject to change without notice.

Honeywell, PlantScape, Experion PKS, and **TotalPlant** are registered trademarks of Honeywell International Inc.

Other brand or product names are trademarks of their respective owners.

Honeywell Process Solutions

1860 West Rose Garden Lane

Phoenix, AZ 85027

About This Document

This document describes mounting, installation and wiring of the XYR 6000 Wireless Transmitters and antennae. Configuration, authentication and operation are covered in other documents.

Honeywell does not recommend using devices for critical control where there is a single point of failure or where single points of failure result in unsafe conditions. OneWireless is targeted at open loop control, supervisory control, and controls that do not have environmental or safety consequences. As with any process control solution, the end-user must weigh the risks and benefits to determine if the products used are the right match for the application based on security, safety, and performance. Additionally, it is up to the end-user to ensure that the control strategy sheds to a safe operating condition if any crucial segment of the control solution fails.

Revision Information

Document Name XYR 6000 Transmitters Quick Start Guide	Document No. 34-XY-25-21 Rev. No.	Publication Date
ATEX and IECEx control drawings and Multi DI manual added	5	April 2009
Product Ratings tables, STUW700/701/8x0, Universal IO, 2dBi and 4dBi antenna and 24V Power Supply details added	6	Sept 2009
FM/CSA/IECEx approval updates	7	Nov 2009
ATEX approval updates	8	March 2010
ISABattery Pack added	9	October 2010
Flange Mount and Remote Seal data, updated Approvals information	10	March 2012
Installation Drawings	11	April 2012
Reference documents and OW R210 software release added	12	February 2013

References

The following list identifies all documents that may be sources of reference for material discussed in this publication.

Document Title	Document number
OneWireless XYR 6000 Pressure Transmitter User's Manual	34-XY-25-15
OneWireless XYR 6000 Temperature and DI Transmitter User's Manual	34-XY-25-16
OneWireless XYR 6000 HLAI Transmitter User's Manual	34-XY-25-17
OneWireless XYR 6000 SmartCET Corrosion Transmitter User's Manual	34-XY-25-18
OneWireless XYR 6000 Multi Discrete Input Transmitter User's Manual	34-XY-25-27
OneWireless XYR 6000 Universal Input/Output User's Manual	34-XY-25-30

Continued on next page

References (continued)

OW-CDX010	OW-CDX010
OneWireless Wireless Builder User's Guide	OW-CDX060
OneWireless Builder Parameter Reference	OW-CDX070
OW R210 Hardware Planning and Installation Guide	OW-CC0010
OW R210 Wireless Device Manager User's Guide	OW-CC0020
OW R210 Field Device Access Point User's Guide	OW-CC0030
OneWireless R210 Parameter Reference Dictionary	OW-CC0050
OneWireless R210 Migration Users Guide	OW-CC0080
OW R210 Software Change Notice	OW-CCSCN1

Support and Contact Info

United States and Canada

Contact: Honeywell Process Solution

- Global Technical Support - Phone: 001-800-423-9883
- Customer Service (HFS) - Phone: 001-800-343-0228
- Outside United States - Phone: 001-215-641-3610

Calls are answered by dispatcher between 6:00 am and 4:00 pm Mountain Standard Time. Emergency calls outside normal working hours are received by an answering service and returned within one hour.

Email support: ask-ssc@honeywell.com

Mail: Honeywell Process Solutions
1860 West Rose Garden Lane,
Phoenix, Arizona 85027

For more contact details for Europe, Asia, North and South Americas, please see back page.

World Wide Web

Honeywell Process Solution Support Online:
www.honeywellprocess.com/

Elsewhere











Call your nearest Honeywell office. See back page for details.

Training Classes

Honeywell Automation College:
<http://www.automationcollege.com>







Symbol Definitions

The following table lists those symbols used in this document to denote certain conditions.

Symbol	Definition
	ATTENTION: Identifies information that requires special consideration.
	TIP: Identifies advice or hints for the user, often in terms of performing a task.
CAUTION	Indicates a situation which, if not avoided, may result in equipment or work (data) on the system being damaged or lost, or may result in the inability to properly operate the process.
	CAUTION: Indicates a potentially hazardous situation which, if not avoided, may result in minor or moderate injury. It may also be used to alert against unsafe practices. CAUTION symbol on the equipment refers the user to the product manual for additional information. The symbol appears next to required information in the manual.
	WARNING: Indicates a potentially hazardous situation, which, if not avoided, could result in serious injury or death. WARNING symbol on the equipment refers the user to the product manual for additional information. The symbol appears next to required information in the manual.
	WARNING, Risk of electrical shock: Potential shock hazard where HAZARDOUS LIVE voltages greater than 30 Vrms, 42.4 Vpeak, or 60 VDC may be accessible.
	ESD HAZARD: Danger of an electro-static discharge to which equipment may be sensitive. Observe precautions for handling electrostatic sensitive devices.
	Protective Earth (PE) terminal: Provided for connection of the protective earth (green or green/yellow) supply system conductor.
	Functional earth terminal: Used for non-safety purposes such as noise immunity improvement. NOTE: This connection shall be bonded to Protective Earth at the source of supply in accordance with national local electrical code requirements.
	Earth Ground: Functional earth connection. NOTE: This connection shall be bonded to Protective Earth at the source of supply in accordance with national and local electrical code requirements.
	Chassis Ground: Identifies a connection to the chassis or frame of the equipment shall be bonded to Protective Earth at the source of supply in accordance with national and local electrical code requirements.

continued

About This Document
Symbol Definitions

Symbol	Definition
	<p>The Factory Mutual® Approval mark means the equipment has been rigorously tested and certified to be reliable.</p>
	<p>The Canadian Standards mark means the equipment has been tested and meets applicable standards for safety and/or performance.</p>
	<p>The Ex mark means the equipment complies with the requirements of the European standards that are harmonised with the 94/9/EC Directive (ATEX Directive, named after the French "ATmosphere EXplosible").</p>
	<p>For radio equipment used in the European Union in accordance with the R&TTE Directive the CE Mark and the notified body (NB) identification number is used when the NB is involved in the conformity assessment procedure. The alert sign must be used when a restriction on use (output power limit by a country at certain frequencies) applies to the equipment and must follow the CE marking.</p>
	<p>The C-Tick mark is a certification trade mark registered to ACMA (Australian Communications and Media Authority) in Australia under the Trade Marks Act 1995 and to RSM in New Zealand under section 47 of the NZ Trade Marks Act. The mark is only to be used in accordance with conditions laid down by ACMA and RSM. This mark is equal to the CE Mark used in the European Union.</p> <p>N314 directly under the logo is Honeywell's unique supplier identification number.</p>
	<p>The INMETRO (Brazil) mark means the tested and meets applicable standards for safety</p>

Contents

1. INTRODUCTION	1
1.1 Site preparation	1
1.2 European Union Usage.....	1
1.3 Certifications and Approvals	2
Hazardous location certifications	2
Electrical Data:	6
Battery	6
DC Supply	6
1.4 Conditions of Certification	6
IECEX Conditions of Certification	6
ATEX Conditions for Safe Use	6
1.5 Maximum Working Pressure:.....	6
1.6 Radio Certifications	7
Radio Frequency (RF) statement	7
European Union restriction	7
Restriction	7
Japanese Restrictions	7
2. TRANSMITTER MOUNTING	9
2.1 Weight	9
2.2 Dimensions	10
2.3 Installation drawing number tables.....	16
2.4 Transmitter location.....	17
Pressure models.....	17
2.5 Conduit / Cable Entries.....	17
2.6 Bracket mounting.....	18
Attach bracket to pipe.....	18
Attach transmitter to bracket.....	19
2.7 Remote Seal Transmitter Mounting.....	20
2.8 Rotate transmitter housing	21
2.9 Rotate display.....	21
Tools required	21
Procedure.....	21
Display adjustment	22
3. PROCESS INSERTION	23
3.1 Pressure models	23
Piping	23
Process connections	25
General piping guidelines.....	26
Insert probe into process	27
Integral probe wiring.....	27
Remote probe wiring	27

3.2 HLA models	28
Connect wiring	28
3.3 Universal I/O	29
Connect wiring	29
Wiring for calibration – XYR6000 Universal I/O Wiring Diagrams for AI/DI (Model STUW700)	30
Wiring for calibration – XYR 6000 Universal I/O Wiring Diagrams for AI/DI/DO (Model STUW701)	31
3.4 Corrosion models	33
Probe mounting locations.....	33
Probe installation	36
Connect wiring	37
4. ANTENNA ADJUSTMENT AND MOUNTING	38
4.1 Requirements	38
Radio installation requirements.....	38
4.2 Integral antenna.....	38
Elbow	39
Straight.....	39
4.3 Remote antenna	40
Outdoor installation warnings.....	40
Choosing a Mounting Location.....	41
Site Selection	41
Mounting the Antenna.....	42
Directional mounting procedure	44
Omnidirectional mounting procedure	45
Grounding the antenna	45
5. START UP	47
5.1 Battery Power Option	47
Connect batteries.....	47
IS Battery Holder, 50025288-502.....	48
Battery replacement procedure	49
IS Battery Pack, 50047517-501	50
IS Battery Pack replacement procedure	50
24 Vdc Power Supply Option (DC) System Diagram	52
5.2 Display sequence.....	53
5.3 Provisioning.....	53
6. CERTIFICATION INSTALLATION REQUIREMENTS.....	55
6.1 Certification Drawings	55
EC Declaration of Conformity.....	55
Schedule	56
CSA Installation Drawings.....	58
ATEX Control Drawings	81
IECEX Control Drawings	93

Tables

Table 1-1 European Union.....	1
Table 1-2 Certifications and Approvals.....	2
Table 1-3 Radio Certifications	7
Table 2-1 Weights.....	9
Table 2-2 Installation Drawing Numbers for Flush, Extended and Pseudo Flanged Models.....	16
Table 2-3 Installation Drawing Numbers for DP Remote Seal Models STRW1xD, STRW9xD	16
Table 2-4 Installation Drawing Numbers for GP/AP Remote Seal Models STRW1xG, STRW9xG, STRW1xA, STRW9xA	16
Table 2-5 Pressure models.....	17
Table 2-6 Conduit entry plugs and cable glands for your XYR 6000 transmitter.	17
Table 2-7 Bracket Attachment	19
Table 2-8 Remote Seal Transmitter Mounting.....	20
Table 3-1 Process connections	25

Figures

Figure 2-1 Temperature/DI/Multi DI/HLAI/Corrosion transmitter dimensions.....	10
Figure 2-2 Universal I/O Temperature/DI/Multi DI/HLAI/Corrosion antenna dimensions.....	11
Figure 2-3 DP/DHGP Pressure transmitter dimensions	12
Figure 2-4 DP/DHGP Pressure antenna dimensions	13
Figure 2-5 GP/AP Pressure transmitter dimensions	14
Figure 2-6 GP/AP Pressure antenna dimensions.....	15
Figure 2-7 Common bracket orientations	18
Figure 2-8 Remote Seal mounting.....	20
Figure 2-9 Rotating transmitter housing	21
Figure 2-10 Display rotation.....	22
Figure 3-1 Typical 3-valve manifold and blow-down piping arrangement	23
Figure 3-2 Typical Arrangement for 1/2" NPT Process Connection Piping.....	24
Figure 3-3 Flange Mounting.....	26
Figure 3-4 Temperature probes.....	27
Figure 3-5 HLA connection	28
Figure 3-6 Voltage input wiring.....	28
Figure 3-7 Current input wiring	28
Figure 3-8 Universal I/O Connection	29
Figure 3-9 Corrosion transmitter with remote probe.....	37
Figure 4-1 Elbow antenna adjustment.....	39
Figure 4-2 Integral straight antenna	39
Figure 4-3 Directional antenna mounting	44
Figure 4-4 Omnidirection antenna mounting	45
Figure 5-1: Battery assembly.....	48
Figure 5-2: IS Battery Pack.....	50
Figure 5-3 Power Option 24V	51
Figure 5-4 External 24V Power Module.....	51
Figure 5-5 Power Supply 24 Vdc Option (DC) System Diagram.....	52

1. Introduction

1.1 Site preparation

Wireless devices require proper site preparation to ensure optimum performance and safety compliance. Do not proceed until you have done the proper planning described in the Wireless Planning Guide.

1.2 European Union Usage

This product may be used in any of the following European Union nations.

Table 1-1 European Union

Country	ISO 3166 2 letter code	Country	ISO 3166 2 letter code
Austria	AT	Latvia	LV
Belgium	BE	Liechtenstein	LI
Bulgaria	BG	Lithuania	LT
Cyprus	CY	Malta	MT
Czech Republic	CZ	Netherlands	NL
Denmark	DK	Norway	NO
Estonia	EE	Poland	PL
Finland	FI	Portugal	PT
France	FR	Romania	RO
Germany	DE	Slovakia	SK
Greece	GR	Slovenia	SI
Hungary	HU	Spain	ES
Iceland	IS	Sweden	SE
Ireland	IE	Switzerland	CH
Italy	IT	United Kingdom	BG

1.3 Certifications and Approvals

Hazardous location certifications

Refer to product label for applicable approvals.

Table 1-2 Certifications and Approvals

AGENCY	TYPE OF PROTECTION	Ambient Temperature	Product Applicability*
CSA 1903673 (USA and Canada)	Intrinsically Safe: Class I; Division 1; Groups A, B, C, D; Class II, Division 1, Groups E, F, G; Class III, Division 1; T4 Class I, Zone 0 Ex ia IIC T4 Class I, Zone 0 AEx ia IIC T4	-40 ° C to +85 ° C : Battery -40 ° C to +80 ° C : DC Supply	Pressure Temperature/ Discrete Inputs Corrosion High Level INPUT (HLAI) Universal I/O
	Nonincendive: Class I; Division 2; Groups A, B, C, D; Class II, Division 2, Groups F, G; Class III, Division 2, T4 Class I, Zone 2 Ex nA IIC, T4 Class I, Zone 2 AEx nA IIC, T4	-40 ° C to +85 ° C : Battery -40 ° C to +80 ° C : DC Supply	Pressure Temperature/ Discrete Inputs High Level INPUT (HLAI) Universal I/O
	Explosion-Proof/ Flameproof: Class I, Division 1; Groups A, B, C, D; Class II, Division 1, Groups E, F, G; Class III, Division 1; T4 Class I, Zone 1 Ex d IIC T4 Class I, Zone 1 AEx d IIC, T4	40 ° C to +85 ° C : Battery -40 ° C to +80 ° C : DC Supply	Pressure Temperature/ Discrete Inputs Corrosion High Level INPUT (HLAI) Universal I/O
	Enclosure: Type 4X/ IP66		
	Standards Used: CSA-C22.2 No. 30:M1986 CSA-C22.2 No. 94:M1991 CSA E60079-0: 2002 CSA E60079-15: 2002 FM 3600: 1998 FM 3615: 2006 UL 916:1998	CSA-C22.2 No. 142:M1987 CSA-C22.2 No. 157:M1992 CSA E60079-1: 2002 CSA E61241-0: 2002 FM 3610: 1999 ANSI/ ISA 12.12.02: 2003	CSA-C22.2 No. 213:M1987 CSA-C22.2 No. 60529:2005 CSA E60079-11: 2002 CSA E61241-1: 2002 FM 3611: 2004 UL 50:2003

AGENCY	TYPE OF PROTECTION	Ambient Temperature	Product Applicability*
FM Approvals™ 3032450 (USA)	Intrinsically Safe: Class I; Division 1; Groups A, B, C, D; Class II, Division 1, Groups E, F, G; Class III, Division 1; T4 Class I, Zone 0 AEx ia IIC T4	-40 ° C to +85 ° C : Battery -40 ° C to +80 ° C : DC Supply	Pressure Temperature/ Discrete Inputs Corrosion High Level INPUT (HLAI) Universal I/O
	Nonincendive: Class I; Division 2; Groups A, B, C, D; Class II, Division 2, Groups F, G; Class III, Division 2, T4 Class I, Zone 2 AEx nA IIC, T4	-40 ° C to +85 ° C : Battery -40 ° C to +80 ° C : DC Supply	Pressure Temperature/ Discrete Inputs High Level INPUT (HLAI) Universal I/O
	Explosion-Proof/ Flameproof: Class I, Division 1; Groups A, B, C, D; Class II, Division 1, Groups E, F, G; Class III, Division 1; T4 Class I, Zone 1 AEx d IIC, T4	-40 ° C to +85 ° C : Battery -40 ° C to +80 ° C : DC Supply	Pressure Temperature/ Discrete Inputs Corrosion High Level INPUT (HLAI) Universal I/O
	Enclosure: Type 4X/ IP66		
	Standards Used: FM 3600:1998 FM 3615:2006 ANSI/ ISA 12.02.01: 2002 ANSI/ IEC 60529: 2004	FM 3610: 2007 FM 3810: 2005 ANSI/ ISA 12.12.02: 2003 ANSI/ NEMA 250: 2003	FM 3611: 2004 ANSI/ ISA 12.00.01: 2002 ANSI/ ISA 12.22.01: 2005

AGENCY	TYPE OF PROTECTION	Ambient Temperature	Product Applicability*
ATEX- KEMA 08ATEX0062X	Intrinsically Safe: II 1 G Ex ia IIB T4 II 1 D Ex tD A20 IP66 T90 oC	-40 ° C to +70 ° C: Battery -40 ° C to +80 ° C : DC Supply	Pressure Temperature/ Discrete Inputs Corrosion High Level INPUT (HLAI) Universal I/O
	Flameproof: II 2 G Ex d [ia] IIB T4 II 2 D Ex tD A21 IP66 T90 oC	-40 ° C to +70 ° C: Battery -40 ° C to +80 ° C : DC Supply	Pressure Corrosion High Level INPUT (HLAI) Universal I/O
	Enclosure: IP66		
	Standards Used: EN 60079-0 : 2006 EN 60079-26 : 2007	EN 60079-1 : 2004 EN 61241-0 : 2006	EN 60079-11 : 2007 EN 61241-1 : 2004

1. Introduction
 Certifications and Approvals

AGENCY	TYPE OF PROTECTION	Ambient Temperature	Product Applicability*
ATEX- DEKRA 08ATEX0074	Nonincendive: II 3 G Ex nA [nL] IIC T4 II 3 D Ex tD A22 IP66 T90 oC	-40 ° C to +84 ° C	Pressure Temperature/ Discrete Inputs Corrosion High Level INPUT (HLAI) Universal I/O
	Enclosure: IP66		
	Standards Used: EN 60079-0 : 2006 EN 61241-1 : 2004	EN 60079-15 : 2005	EN 61241-0 : 2006

AGENCY	TYPE OF PROTECTION	Ambient Temperature	Product Applicability*
IECEX- CSA 09.0001X	Intrinsically Safe: Ex ia IIB T4 Ex tD A20 IP66 T90 oC	-40 ° C to +70 °C: Battery -40 ° C to +80 ° C : DC Supply	Pressure Temperature/ Discrete Inputs Corrosion High Level INPUT (HLAI) Universal I/O
	Flameproof: Ex d [ia] IIB T4 Ex tD A21 IP66 T90 oC	-40 ° C to +70 ° C: Battery -40 ° C to +80 ° C : DC Supply	Pressure Corrosion High Level INPUT (HLAI) Universal I/O
	Nonincendive: Ex nA [nL] IIC T4 Ex tD A22 IP66 T90 oC	-40 ° C to +84 ° C: Battery -40 ° C to +80 ° C : DC Supply	Pressure Temperature/ Discrete Inputs Corrosion High Level INPUT (HLAI) Universal I/O
	Enclosure: IP66		
	Standards Used: IEC 60079-0 : 2004 IEC 60079-26 : 2007 IEC 60079-15 : 2001	IEC 60079-1 : 2003 IEC 61241-0 : 1999	IEC 60079-11 : 1999 IEC 61241-1 : 1999

AGENCY	TYPE OF PROTECTION	Ambient Temperature	Product Applicability*
SAEx S/09-036X (South Africa)	Intrinsically Safe: Ex ia IIB T4 Ex tD A20 IP66 T90 oC	-40 ° C to +70 ° C: Battery -40 ° C to +80 ° C : DC Supply	Pressure Temperature/ Discrete Inputs Corrosion High Level INPUT (HLAI) Universal I/O
	Flameproof: Ex d [ia] IIB T4 Ex tD A21 IP66 T90 oC	-40 ° C to +70 ° C: Battery -40 ° C to +80 ° C : DC Supply	Pressure Corrosion High Level INPUT (HLAI) Universal I/O
	Nonincendive: Ex nA [nL] IIC T4 Ex tD A22 IP66 T90 oC	-40 ° C to +84 ° C: Battery -40 ° C to +80 ° C : DC Supply	Pressure Temperature/ Discrete Inputs Corrosion High Level INPUT (HLAI) Universal I/O
	Enclosure: IP66		
	Standards Used: SANS (IEC) 60079-0 : 2005 IEC 60079-1 : 2003 IEC 61241-0 : 1999	SANS (IEC) 60079-15 : 2006 IEC 60079-11 : 1999 IEC 61241-1 : 1999	ARP 0108 (Edition 1.1) IEC 60079-26 : 2007

AGENCY	TYPE OF PROTECTION	Ambient Temperature	Product Applicability*
INMETRO** NCC 11.0331 X (BRAZIL)	Intrinsically Safe: Ex ia IIB T4 Ga	-40 °C to +70 °C: Battery -40 °C to +80 °C : DC Supply	Pressure Temperature/ Discrete Inputs Corrosion High Level INPUT (HLAI) Universal I/O
	Flameproof: Ex d [ia] IIB T4 Ex tb IIIC T90 oC IP66	-40 °C to +70 °C: Battery -40 °C to +80 °C : DC Supply	Pressure Corrosion High Level INPUT (HLAI) Universal I/O
	Nonincendive: Ex nA [ic] IIC T4 Ex tc IIIC T90 oC IP66	-40 °C to +84 °C: Battery -40 °C to +80 °C : DC Supply	Pressure Temperature/ Discrete Inputs Corrosion High Level INPUT (HLAI) Universal I/O
	Enclosure: IP66		
	Standards Used: ABNT NBR IEC 60079-0:2008 IEC 60079-15:2010 ABNT NBR IEC 60529:2009	ABNT NBR IEC 60079-1:2009 ABNT NBR IEC 60079- 26:2008 IEC 61241-0 : 1999	ABNT NBR IEC 60079-11:2009 IEC 60079-31:2008 IEC 61241-1 : 1999

*See individual Product manuals as defined on page iii for exact Models

** At time of Printing Certification was pending.

Electrical Data:

Battery

Two in series connected (D size) Lithium batteries, type 5930 manufactured by Tadiran, type XL-205F manufactured by Zeno Energy or type PT-2300H manufactured by Eagle Picher.

Additionally for ATEX and IECEx certifications, Lithium Battery SL-2780, manufactured by Tadiran, GmbH may be used.

DC Supply

For Ordinary Locations, Explosion-proof and Non Incendive:

16.0 V min to 28.0 V max, Current = 100 mA

For Intrinsically Safe:

A Barrier, MTL 728P+ or MTL 7728P+ mounted in a suitable enclosure, or in a non-hazardous location is needed, see Agency Certification drawings in Section 6.

For Output parameters associated with Temperature/ Discrete Inputs, Corrosion, High Level INPUT (HLAI) or Universal I/O, see Agency Certification drawings in Section 6.

1.4 Conditions of Certification

IECEx Conditions of Certification

Parts of the antenna are non-conducting and the area of the non-conducting part exceeds the maximum permissible areas for Category II 1 G (Zone 0) according to IEC 60079-0. Therefore when the antenna is used within a potentially explosive atmosphere, appropriate measures must be taken to prevent electrostatic discharge.

Impact and friction hazards need to be considered according to IEC 60079-0 when the transmitter that is exposed to the exterior atmosphere is made of light metal alloys, and used in Category II 1 G (Zone 0).

ATEX Conditions for Safe Use

Because the enclosure of the XYR 6000 Wireless Transmitter is made from aluminum, if it is mounted in an area where the use of category 1G apparatus is required, it must be installed such that even in the event of rare incidents, ignition sources due to impact and friction sparks are excluded.



Special precautions shall be taken to prevent the surface of the antenna of the XYR 6000 Wireless Transmitter from being electrostatically charged.

1.5 Maximum Working Pressure:

See individual Product manuals as defined on [page iii](#)

1.6 Radio Certifications

Table 1-3 Radio Certifications

Agency	Certification	Description
Federal Communications Commission (FCC)	FCC ID: S5750016517 or FCC ID: S5750025034	The XYR 6000 Wireless Transmitters comply with part 15 of the FCC rules. Operation is subject to the following two conditions. (1) this device may not cause harmful interference, and (2) this device must accept any interference received, including interference that may cause undesired operation.
Industry Canada (IC)	IC: 573I-50016517 or IC: 573I-50025034	The installer of this radio equipment must ensure that the antenna is located or pointed such that it does not emit RF fields in excess of Health Canada limits for the general population; consult Safety Code 6, obtainable from Health Canada's web site www.hc-sc.gc.ca/rpb .
 0981	0981	For radio equipment used in the European Union in accordance with the R&TTE Directive the CE Mark and the notified body (NB) identification number is used when the NB is involved in the conformity assessment procedure. The alert sign must be used when a restriction on use (output power limit by a country at certain frequencies) applies to the equipment and must follow the CE marking.
		Radio certification by the Brazilian National telecom Agency.

Radio Frequency (RF) statement

To comply with FCC's and Industry Canada's RF exposure requirements, the following antenna installation and device operating configurations must be satisfied.

- Remote Point-to-Multi-Point antenna(s) for this unit must be fixed and mounted on outdoor permanent structures with a separation distance between the antenna(s) of greater than 20cm and a separation distance of at least 20cm from all persons.
- Remote Fixed Point-to-Point antenna(s) for this unit must be fixed and mounted on outdoor permanent structures with a separation distance between the antenna(s) of greater than 20cm and a separation distance of at least 100cm from all persons.
- Furthermore, when using integral antenna(s) the XYR 6000 Wireless Transmitter unit must not be co-located with any other antenna or transmitter device and have a separation distance of at least 20cm from all persons.

European Union restriction

The XYR 6000 Wireless Transmitters are in conformity with the applicable portions of the ETSI standards as required by the R&TTE Directive 1999/5/EC.

Restriction

France restricts outdoor use to 10mW (10dBm) EIRP in the frequency range of 2,454-2,483.5 MHz. Installations in France must limit EIRP to 10dBm, for operating modes utilizing frequencies in the range of 2,454 – 2,483.5MHz.

Japanese Restrictions

For locations in Japan the transmitter power is restricted to 12.14dBm/Mhz {(32mW (15.4 dBm)) maximum EIRP including the antenna.

2. Transmitter Mounting

2.1 Weight

Table 2-1 Weights

Transmitter Model	Weight
STDW1xx STDW9xx STGW9x4 STRW1xD STRW9xD	11 lbs (5 kg)
STAW14L STRW14A STRW1xG STRW9xG STGW1xL STGW9xL	7 lbs (3.2 kg)
STFW1xF STFW9xF	17 lbs (7.7 kg) for 2" 150# flanged head 21 lbs (9.5 kg) for 3" 150# flanged head
STFW1xx STFW9xx	23 to 36 lbs (10.5 kg to 16.4 kg) depending on flange size
STIW400 STTW40x STTW500 STIW600 STUW700 STUW701 STTW8x0 CETW6000M	6 lbs (2.7 kg)

Note: Add 8.0 pounds (3.6 kg) to any model equipped with the stainless steel housing option (Model Selection Guide Table IV selections A3 or SH)

2.2 Dimensions

For Flange and Remote Seal transmitter dimensions, obtain appropriate installation drawing using Installation drawing number tables on page 16 as a guide.

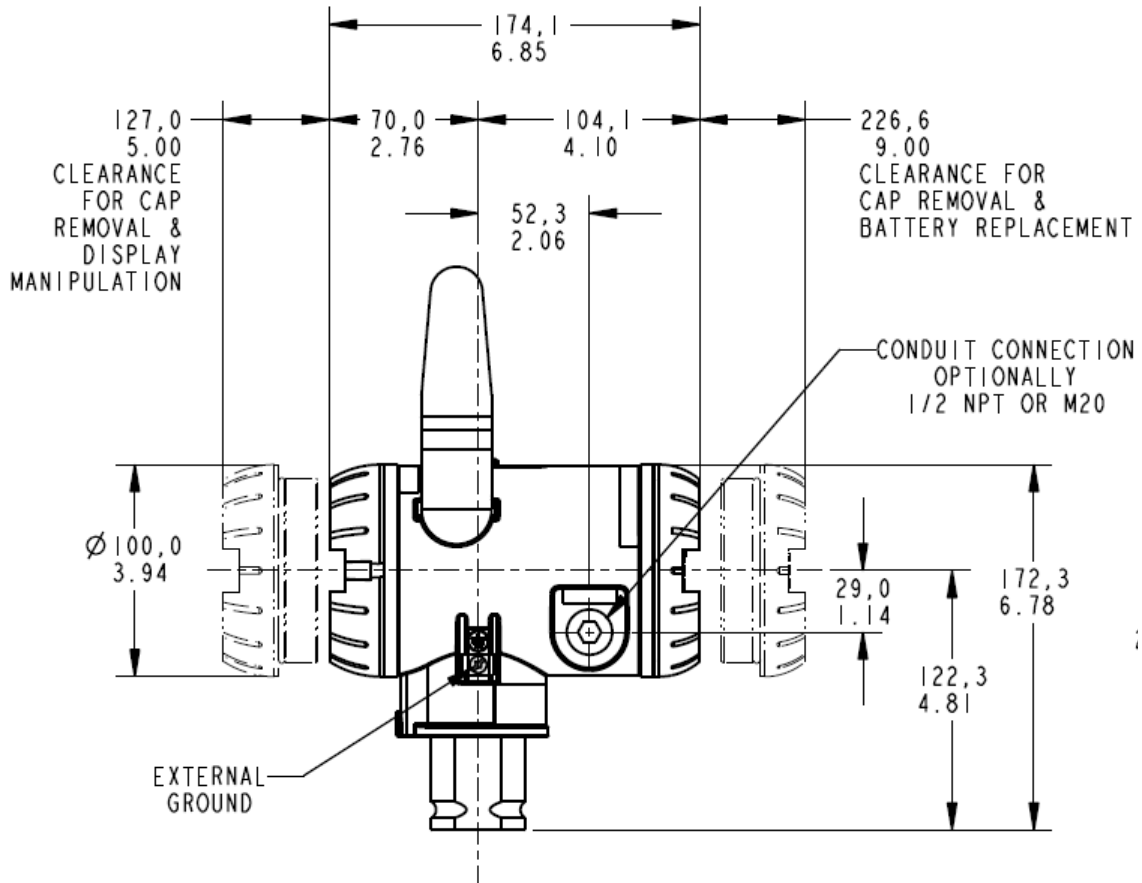

Figure 2-1 Temperature/DI/Multi DI/HLAI/Corrosion transmitter dimensions

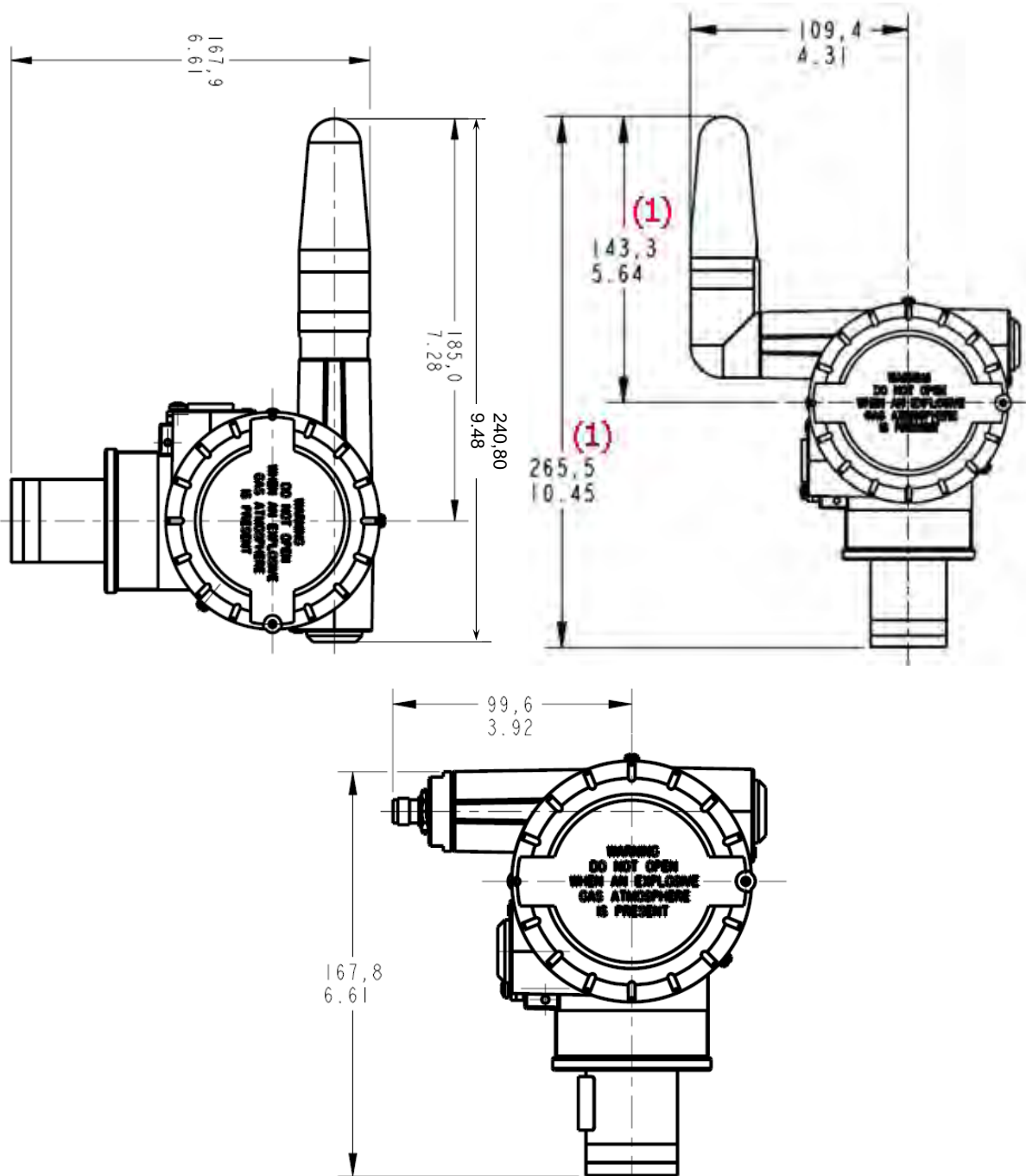

Figure 2-2 Universal I/O Temperature/DI/Multi DI/HLAI/Corrosion antenna dimensions

(1) Add 139,0mm/5.47 in. To these dimensions for transmitters supplied with 4 dBi Antenna option.

2. Transmitter Mounting
Dimensions

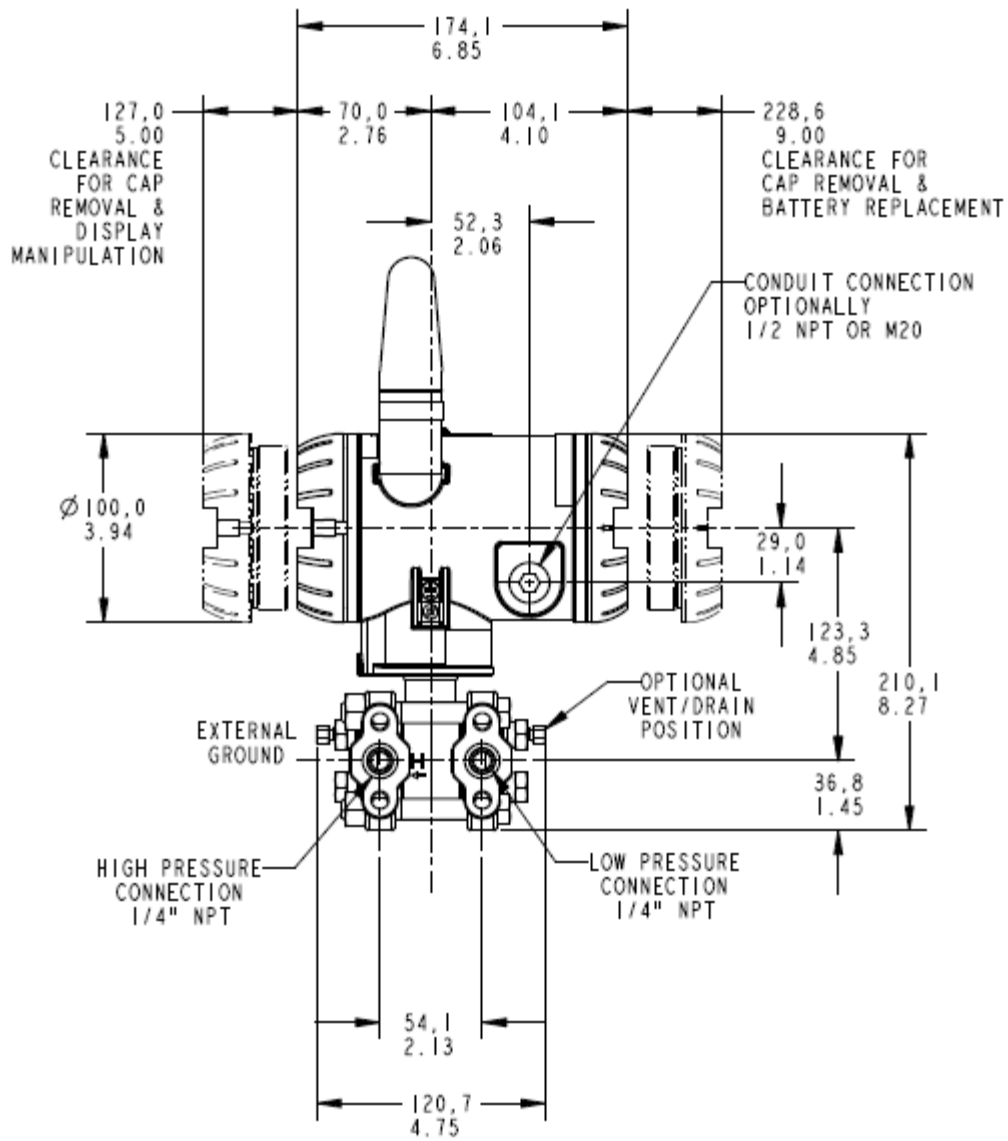

Figure 2-3 DP/DHGP Pressure transmitter dimensions

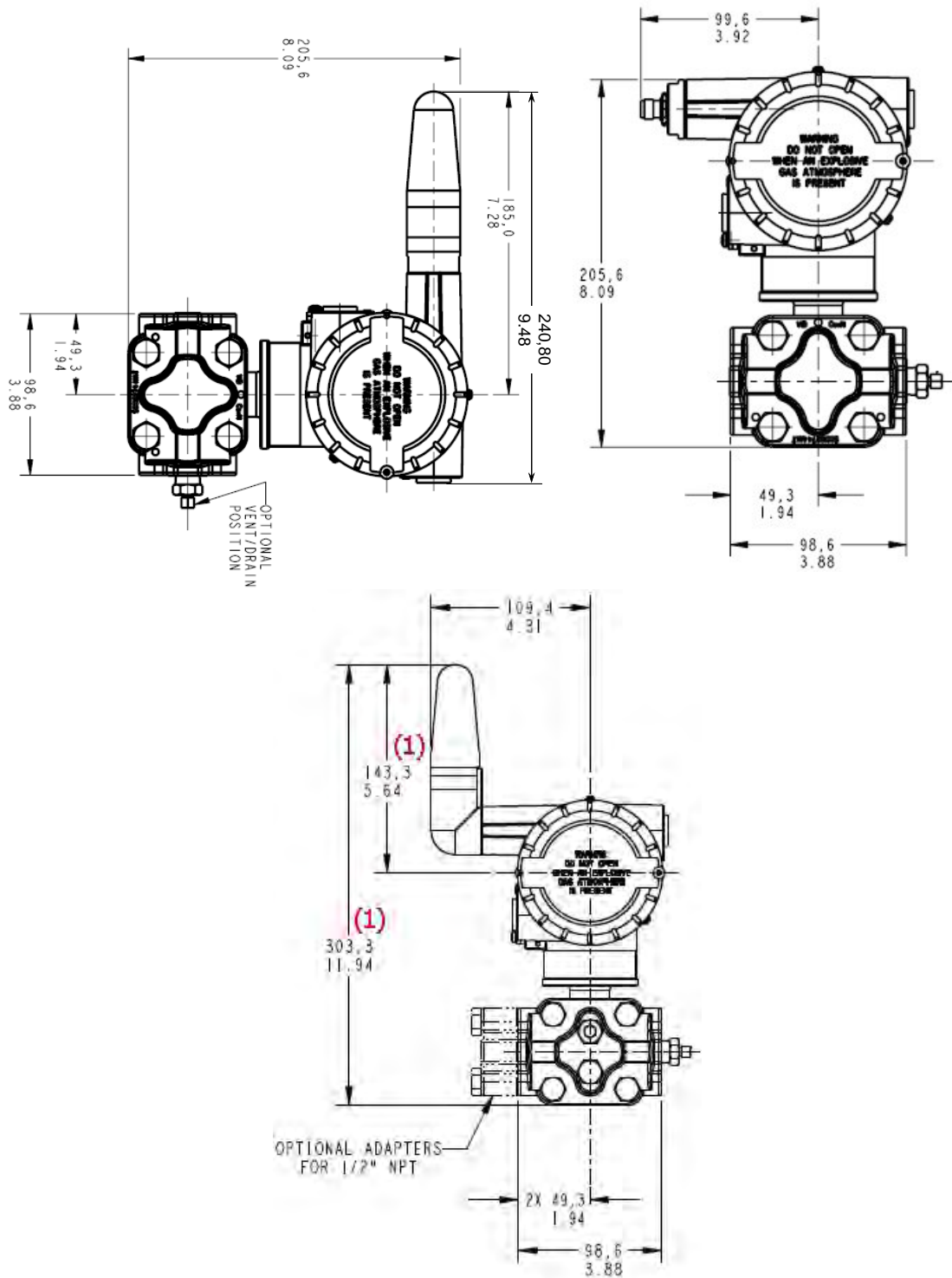

Figure 2-4 DP/DHGP Pressure antenna dimensions

(1) Add 139,0mm/5.47 in. To these dimensions for transmitters supplied with 4 dBi Antenna option.

**2. Transmitter Mounting
Dimensions**

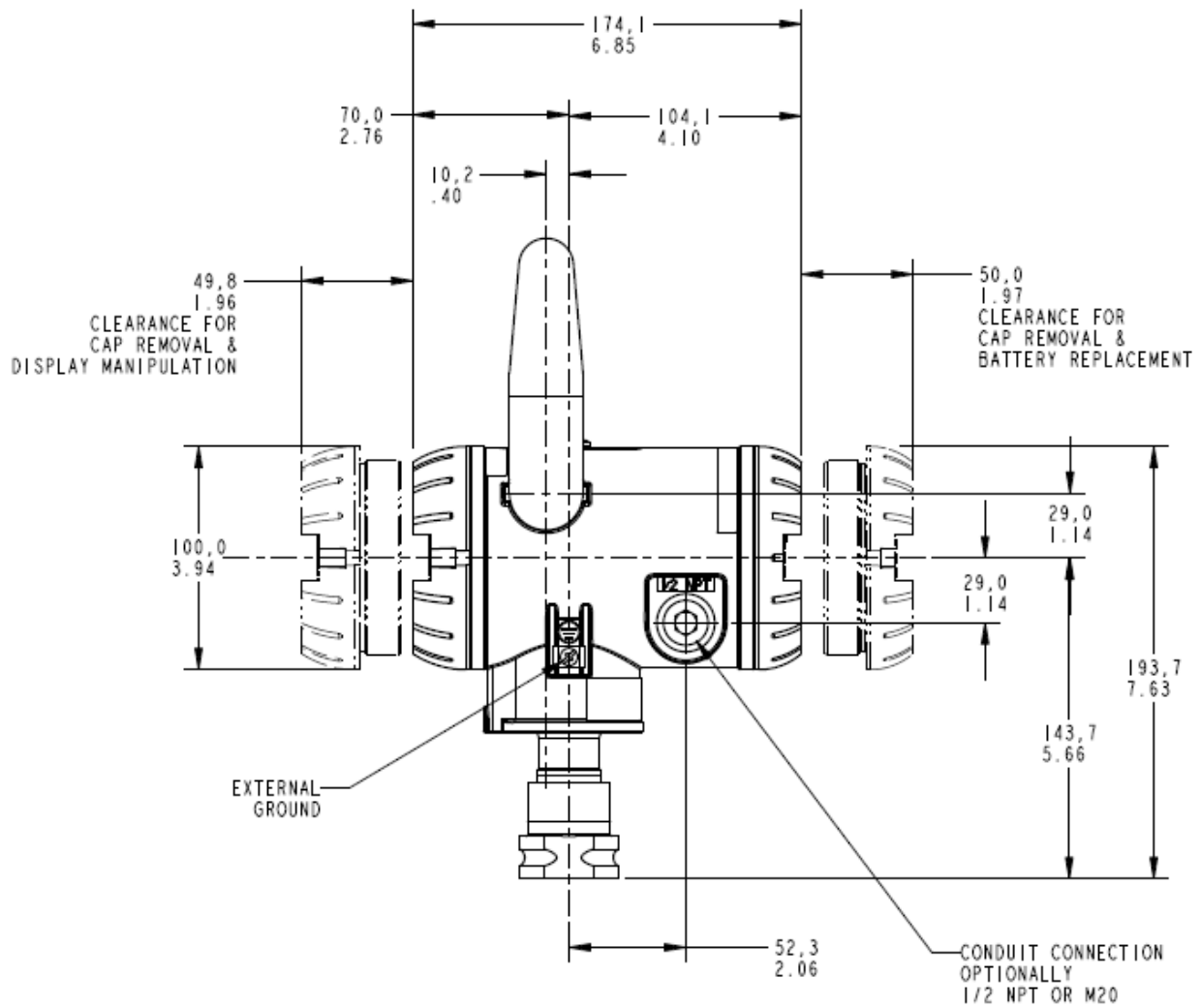

Figure 2-5 GP/AP Pressure transmitter dimensions

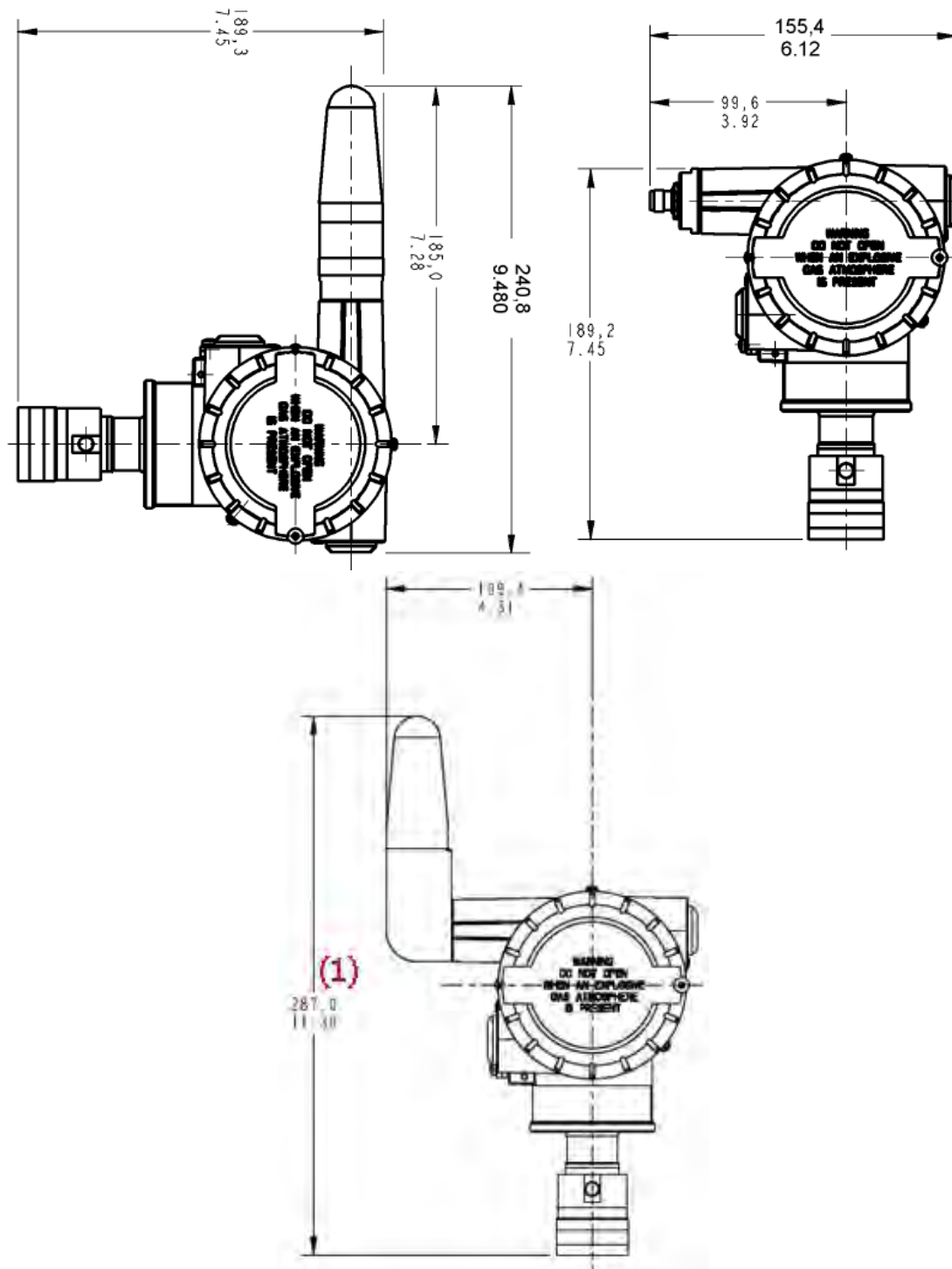

Figure 2-6 GP/AP Pressure antenna dimensions

(1) Add 139,0mm/5.47 in. To these dimensions for transmitters supplied with 4 dBi Antenna option.

2. Transmitter Mounting

Installation drawing number tables

2.3 Installation drawing number tables

Table 2-2 Installation Drawing Numbers for Flush, Extended and Pseudo Flanged Models

STFW1xx, STFW9xx, Flush Flange	50060110
STFW1xx, STFW9xx Extended Flange	50060111
STFW1xF, STFW9xF Pseudo Flange	50060112

Table 2-3 Installation Drawing Numbers for DP Remote Seal Models STRW1xD, STRW9xD

	With 1 Remote Seal on High Side	With 1 Remote Seal on Low Side	With 2 Remote Seals
Flat Bracket Horizontal	50060115	50060119	50060829
Flat Bracket Vertical	50060116	50060120	50060830
Angle Bracket Horizontal	50060117	50060121	50060831
Angle Bracket Vertical	50060118	50060122	50060832

**Table 2-4 Installation Drawing Numbers for GP/AP Remote Seal Models STRW1xG,
STRW9xG, STRW1xA, STRW9xA**

Flat Bracket Horizontal	50060131
Flat Bracket Vertical	50060132
Angle Bracket Horizontal	50060133
Angle Bracket Vertical	50060134

2.4 Transmitter location

Pressure models

Table 2-5 Pressure models

Process	Suggested location	Explanation
Gases	Above the gas line	The condensate drains away from the transmitter.
Liquids	<ul style="list-style-type: none"> Below but close to the elevation of the process connection. Level with or above the process connection. 	<ul style="list-style-type: none"> This minimizes the static head effect of the condensate. This requires a siphon to protect the transmitter from process steam. The siphon retains water as a "fill fluid."

2.5 Conduit / Cable Entries



NOTICE



THIS PRODUCT IS SUPPLIED WITH PLASTIC DUST PLUGS IN THE CONDUIT/CABLE GLAND ENTRIES. IT IS THE USERS RESPONSIBILITY TO PROVIDE CABLE GLANDS, ADAPTORS AND/OR BLANKING PLUGS SUITABLE FOR THE ENVIRONMENT IN WHICH THIS PRODUCT IS INSTALLED. WHEN INSTALLED IN A HAZARDOUS LOCATION THE CABLE GLANDS, ADAPTORS AND/OR BLANKING PLUGS SHALL ADDITIONALLY BE SUITABLE FOR THE HAZARDOUS LOCATION, THE PRODUCT CERTIFICATION AND ACCEPTABLE TO THE AUTHORITY HAVING JURISDICTION FOR THE INSTALLATION

Summary

Table 2-6 Conduit entry plugs and cable glands for your XYR 6000 transmitter.

Factory Part No.	Description	Environmental rating	Ambient	Hazardous Location Certification
50000547-001	M20 Conduit Plug	IP66-68, 4X, 6P	-40 – 85°C -40 – 185°F	ATEX  II 2 GD EEx de IIC
50021832-002	½ NPT Conduit Plug	IP66-68, 4/4X, 6/6P	-40 – 85°C -40 – 185°F	ATEX  II 2 GD EEx d IIC; CSAcus CL I, Zone 1, Ex/AEx d IIC; CL I, Div 1 & 2, GP ABCD; CL II, Div 1 & 2, GP EFG; CL III, Div 1 & 2
50023232-001	M20 Cable Gland	IP68	-40 – 100°C -40 – 212°F	-----
50023212-001	½ NPT Cable Gland	IP68	-40 – 100°C -40 – 212°F	-----

2.6 Bracket mounting

Attach bracket to pipe

Figure 2-7 shows some commonly used bracket and pipe orientations. Not all possibilities are shown; you can use any bracket (flat or angle) and orientation (parallel or transverse) to get the desired transmitter positioning.

Position bracket on 2-inch (50.8 mm) pipe and install “U” bolt around pipe and through holes in bracket. Secure with nuts and lockwashers provided.

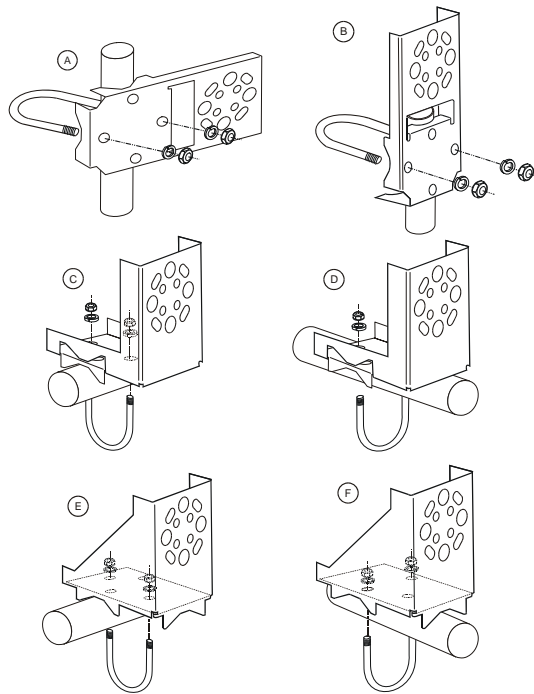

Figure 2-7 Common bracket orientations

Attach transmitter to bracket

Align appropriate mounting holes in transmitter with holes in bracket and secure the transmitter to the bracket with bolts and washers provided.

If the meter body is hexagonal, you must use the additional bracket supplied. If meter body is round, discard the bracket.

Table 2-7 Bracket Attachment

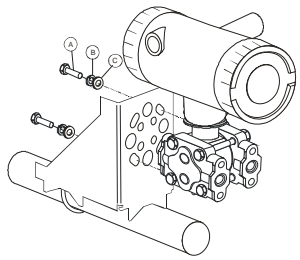
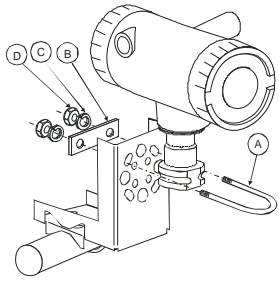
Transmitter type	Attachment to bracket	Example
DP type with double-ended process heads and/or remote seals	Alternate mounting holes in end of heads.	
Dual head GP	Mounting holes in end of process head	
In-line GP and AP (LGP model)	Smaller "U" bolt.	
Temperature/DI	Smaller "U" bolt.	
Multiple DI	Smaller "U" bolt.	
High Level Analog Input	Smaller "U" bolt.	
Corrosion	Smaller "U" bolt.	
Universal I/O	Smaller "U" bolt.	

In flush flange, extended flange and pseudo flange pressure transmitter applications, the transmitter bolts directly to the process connection (tank spud) and no bracket is required.

2.7 Remote Seal Transmitter Mounting

XYR 6000 transmitters furnished with remote diaphragm seals (Model STRWxxx) can be mounted using the optional mounting brackets. Follow the guidelines below to determine the mounting position of the transmitter for the given secondary capillary fill fluid.

Table 2-8 Remote Seal Transmitter Mounting

IF the Capillary (Secondary) Fill is:	THEN mount the Pressure Transmitter:
Silicone DC® 200	no greater than 22 feet (6.7 meters) above the lower remote seal.
Silicone DC® 704	no greater than 19 feet (5.8 meters) above the lower remote seal.
Chlorotrifluoroethylene (CTFE)	no greater than 11 feet (3.4 meters) above the lower remote seal.

Note: The combination of tank vacuum and capillary head effect should not exceed 9 psi (300 mmHg) absolute

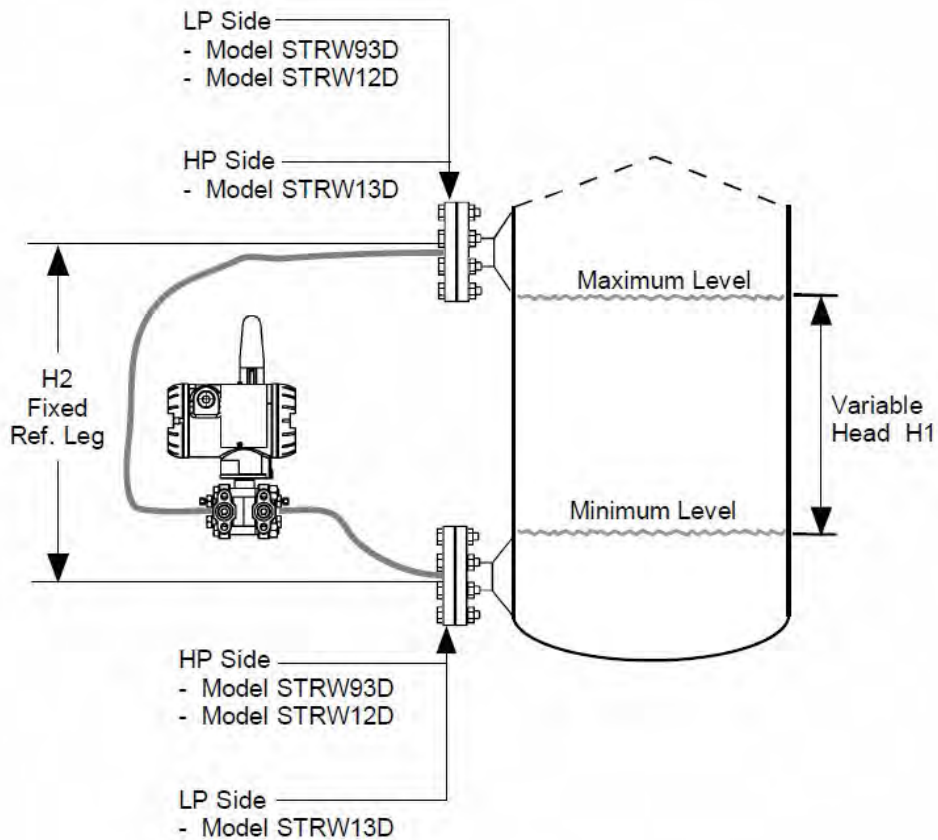

Figure 2-8 Remote Seal mounting

2.8 Rotate transmitter housing

You can rotate the transmitter for better viewing, access, or antenna position. Loosen set screw (see A in Figure 2-9) on outside neck of transmitter one full turn. Rotate transmitter housing up to 180 degrees in either direction to desired position.

CAUTION Do not rotate the housing past 180 degrees in any direction or you could damage the internal wiring.

Tighten set screw.

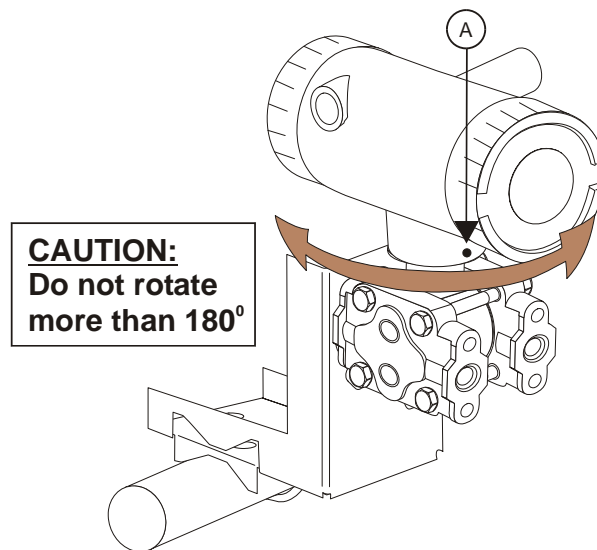

Figure 2-9 Rotating transmitter housing

2.9 Rotate display

If the transmitter's mounting is such that the display is not horizontal, you can rotate the display in 90 degree increments to provide horizontal viewing.

Tools required

- #1 Phillips Screwdriver or 1/8" Slotted Screwdriver
- Torque Screwdriver
- 1.5 mm hex key

Procedure



WARNING

Risk of death or serious injury by explosion. Do not open transmitter enclosure when an explosive gas atmosphere is present.

2. Transmitter Mounting

Rotate display



CAUTION

Take precautions against electrostatic discharge to prevent damaging the display/sensor module.

Display adjustment

Step	Action
1	Honeywell recommends that the transmitter be removed from service and moved to a clean area before servicing.
2	Loosen the M3 locking set screw on the display end-cap. See item 1 in Figure 2-10. Unscrew and remove the end cap.
3	Loosen the two captive screws on the display/sensor module. See items 2 in Figure 2-10.
4	Rotate the display 90 or 180 degrees in either direction so the screws line up with the threaded holes. Do not rotate more than 180 degrees or you could damage the wires behind the display.
5	Re-attach the display's two captive screws. Tighten to 0,4 – 0,6 N-m (3.5 – 5.3 lb-in.).
6	Replace end cap and tighten M3 locking screw.

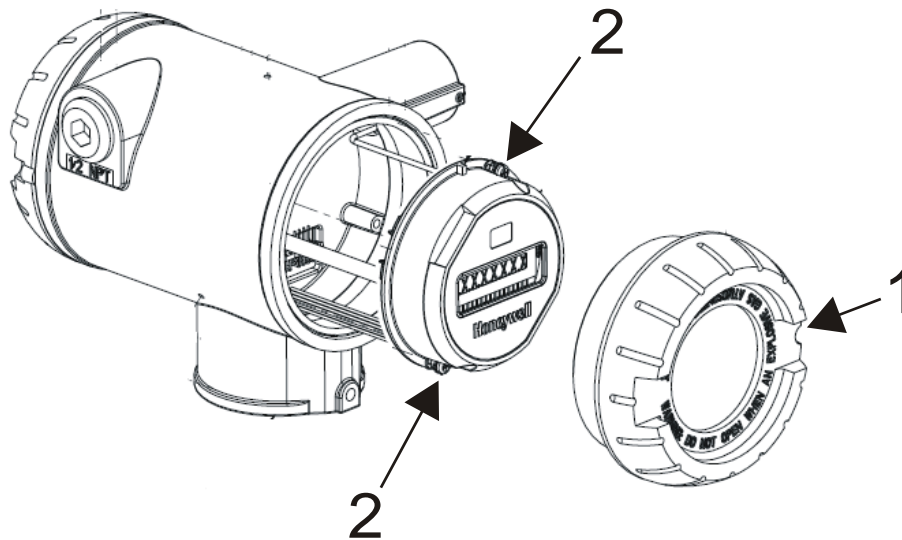

Figure 2-10 Display rotation

3. Process Insertion

3.1 Pressure models

Piping

The actual piping arrangement will vary depending upon the process measurement requirements and the transmitter model. Except for flanged and remote diaphragm seal connections, process connections are made to ¼ inch or ½ inch NPT female connections in the process head of the transmitter’s meter body. For example, a differential pressure transmitter comes with double ended process heads with ¼ inch NPT connections but they can be modified to accept ½ inch NPT through optional flange adapters. Some gauge pressure transmitters may have a ½ inch NPT connection which mounts directly to a process pipe.

The most common type of pipe used is ½ inch schedule 80 steel pipe. Many piping arrangements use a three-valve manifold to connect the process piping to the transmitter. A manifold makes it easy to install and remove or rezero a transmitter without interrupting the process. It also accommodates the installation of blow-down valves to clear debris from pressure lines to the transmitter.

Figure 3-1 shows a diagram of a typical piping arrangement using a 3-valve manifold and blow-down lines for a differential pressure transmitter being used to measure flow.

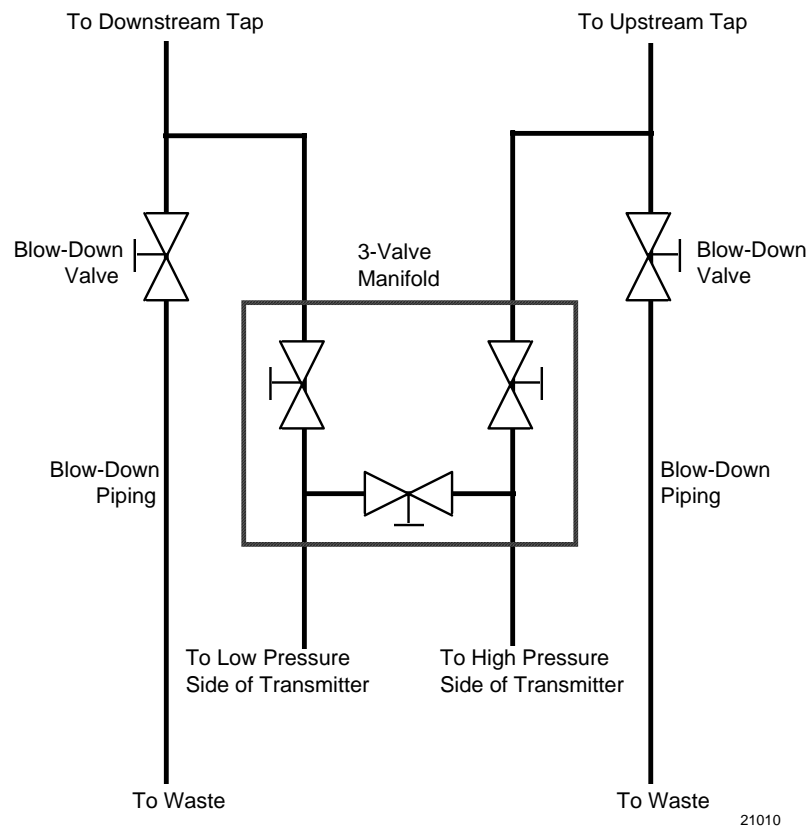

Figure 3-1 Typical 3-valve manifold and blow-down piping arrangement

Another piping arrangement uses a block-off valve and a tee connector in the process piping to the transmitter as shown in Figure 3-2.

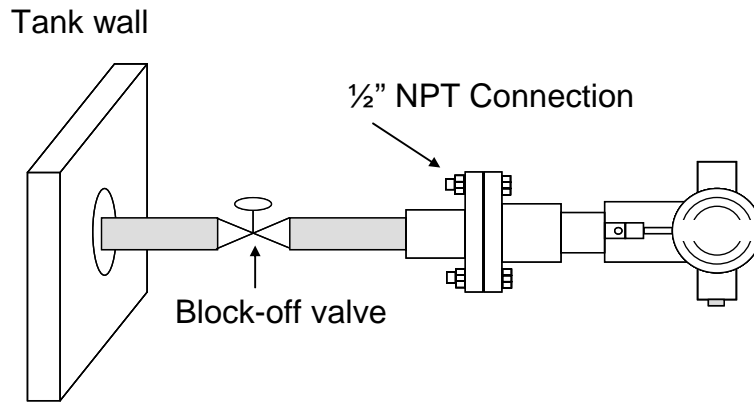

Figure 3-2 Typical Arrangement for 1/2" NPT Process Connection Piping



ATTENTION

For liquid or steam, the piping should slope a minimum of 25.4 mm (1 inch) per 305 mm (1 foot). Slope the piping down towards the transmitter if the transmitter is below the process connection so the bubbles may rise back into the piping through the liquid. If the transmitter is located above the process connection, the piping should rise vertically above the transmitter; then slope down towards the flowline with a vent valve at the high point. For gas measurement, use a condensate leg and drain at the low point (freeze protection may be required here).



CAUTION

Property damage may result if operating temperature limits of transmitter are exceeded. Electronics housing must not exceed 85° C [185° F], meterbody temperature limit may be rated higher. Consult transmitter nameplate for meterbody temperature limits. To reduce the temperature of the process that comes into contact with the transmitter meter body, install impulse piping. As a general rule there is a 56 degree C drop (100 degrees F) in the temperature of the process for every foot (305 mm) of 1/2 inch uninsulated piping.

Process connections

Table 3-1 Process connections

Transmitter Type	Process Connection
Differential Pressure	Process heads with ¼ inch NPT female connection Flange adapters and manifolds with ½ inch female connection are optional
Gauge Pressure	Process head with ½ inch NPT female connection In-line ½ inch NPT female connection In-line ½ inch NPT male 9/16 High Pressure DIN19213n Process heads with ¼ inch NPT female connection Flange adapters and manifolds with ½ inch female connections are optional
Absolute Pressure	Process head with ½ inch NPT female connection In-line ½-inch NPT male 9/16 High Pressure DIN19213n
Flush or Extended Flange Mount	ASME 2" 150# ¹ Serrated-face flange with 4 holes 19 mm (3/4") diameter on 120,7 mm (4.75") bolt circle and an outside diameter of 150 mm (5.91") ASME 2" 300# ¹ Serrated-face flange with 8 holes 19 mm (3/4") diameter on 127 mm (5.00") bolt circle and an outside diameter of 165 mm (6.50") ASME 3" 150# ¹ Serrated-face flange with 4 holes 19 mm (3/4") diameter on 152,4 (6.00") bolt circle and an outside diameter of 190 mm (7.48") ASME 3" 300# ¹ Serrated-face flange with 8 holes 22 mm (7/8") diameter on 168,3 mm (6.63") bolt circle and an outside diameter of 210 mm (8.27") ASME 4" 150# ¹ Serrated-face flange with 8 holes 19 mm (3/4") diameter on 190,5 mm (7.48") bolt circle and an outside diameter of 230 mm (9.06") ASME 4" 300# ¹ Serrated-face flange with 8 holes 22 mm (7/8") diameter on 200 mm (7.87") bolt circle and an outside diameter of 255 mm (10.04") DN 50 PN 40 ² Serrated-face flange with 4 holes 18 mm (.71") diameter on a 125 mm (4.92") bolt circle and an outside diameter of 165 mm (6.50") DN 80 PN 40 ² Serrated-face flange with 8 holes 18 mm (.71") diameter on a 160 mm (6.30") bolt circle and an outside diameter of 200 mm (7.87") DN 100 PN 40 ² Serrated-face flange with 8 holes 22 mm (.87") diameter on a 190 mm (7.48") bolt circle and an outside diameter of 235 mm (9.25")
Pseudo Flange Mount	ASME 2" 150# ¹ Serrated-face flange with 4 holes 19 mm (3/4") diameter on 120,7 mm (4.75") bolt circle and an outside diameter of 150 mm (5.91") ASME 3" 150# ¹ Serrated-face flange with 4 holes 19 mm (3/4") diameter on 152,4 (6.00") bolt circle and an outside diameter of 190 mm (7.48")
Remote Diaphragm Seals	See Model Selection Guide for description of available Flanged, Threaded, Chemical Tee, Saddle and Sanitary process connections.

¹ Dimensions of bolt circle and serrated gasket face conform to ASME B 16.5

² Dimensions of bolt circle and serrated gasket face conform to EN 1092

General piping guidelines

When measuring fluids containing suspended solids, install permanent valves at regular intervals to blow-down piping.

Blow-down all lines on new installations with compressed air or steam and flush them with process fluids (where possible) before connecting these lines to the transmitter's meter body.

Be sure all the valves in the blow-down lines are closed tight after the initial blow-down procedure and each maintenance procedure after that.

Mount transmitter vertically to assure best accuracy. Position the spirit balance on pressure connection surface of AP body.

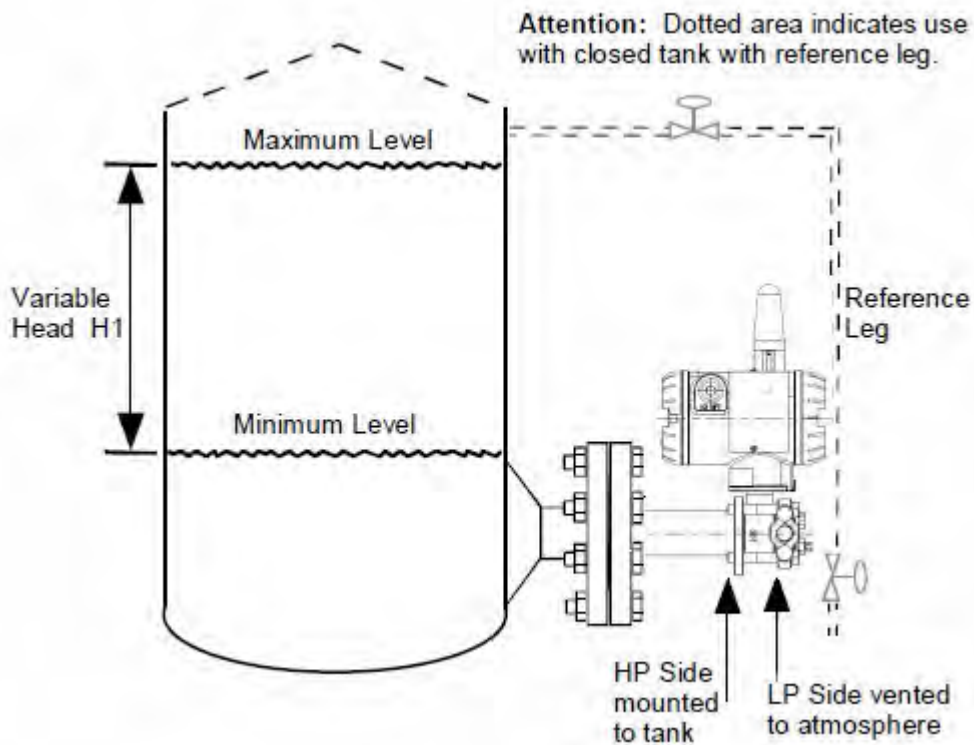

Figure 3-3 Flange Mounting

Temperature and Discrete Input models

Insert probe into process



ATTENTION

It is your responsibility to supply a suitable sealing method or gasket and mounting hardware for the probe's service conditions.

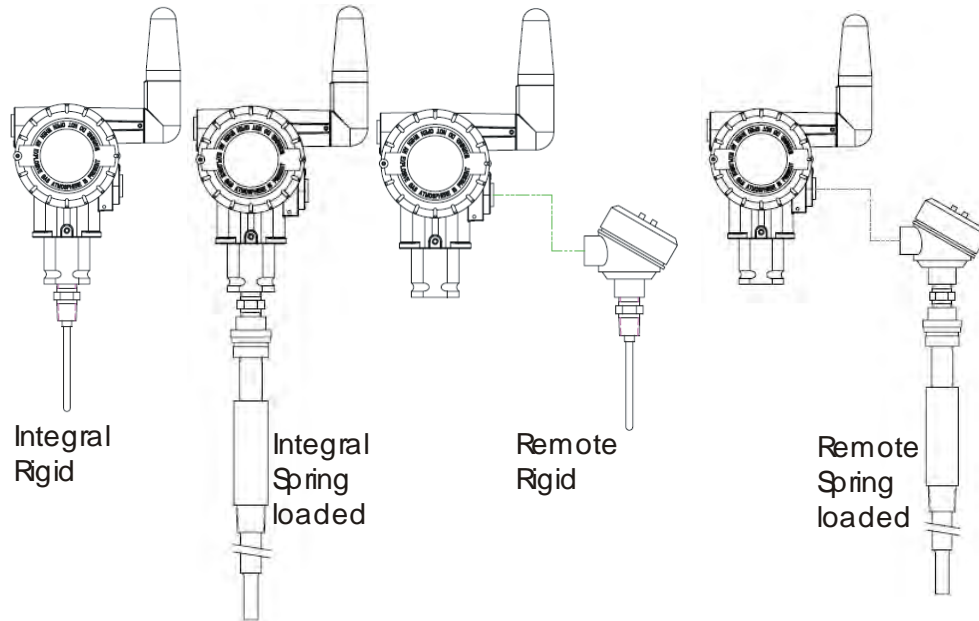

Figure 3-4 Temperature probes

Integral probe wiring

The integral probe is pre-wired to the transmitter at the factory.

Remote probe wiring

Step	Action
1	See Figure 3-4. Open the transmitter's rear end cap (opposite end from display) by loosening the M3 locking screw and unscrewing the end cap.
2	Open the cable gland (on right side below antenna). (Cable gland must be ordered as an option.)
3	Feed wiring (6 to 8 mm allowed diameter) through the cable gland and connect to terminal block. For terminal connections see info starting on page 55.
4	Plug battery connector into batteries. See page 47.
5	Close rear end cap and cable gland.
6	Tighten M3 locking screw on the rear end cap.

3.2 HLAI models

Connect wiring

Step	Action
1	See Figure 3-5. Open the rear end cap (opposite end from display) by loosening the M3 locking screw and unscrewing the end cap.
2	Open the cable gland (on right side below antenna). (Cable gland must be ordered as an option.)
3	Feed wiring (allowed diameter 6 to 8 mm) from other transmitter through the cable gland and connect to terminal block using either voltage or current but not both. See Figure 3-6 or Figure 3-7. For hazardous locations see info starting on page 55.
4	Plug battery connector into batteries.
5	Close rear end cap and cable gland.
6	Tighten M3 locking screw on the rear end cap.

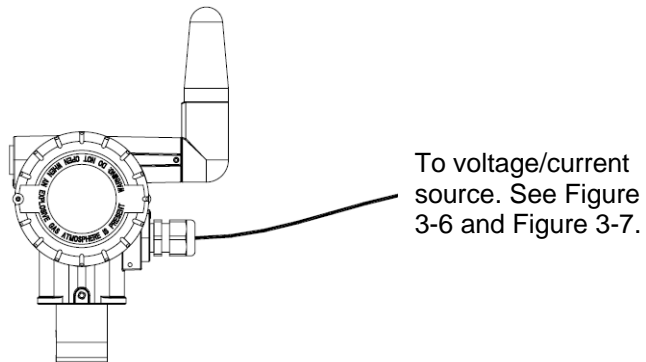

Figure 3-5 HLAI connection

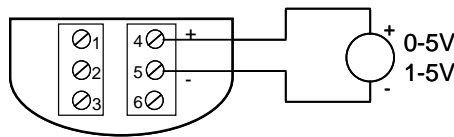

Figure 3-6 Voltage input wiring

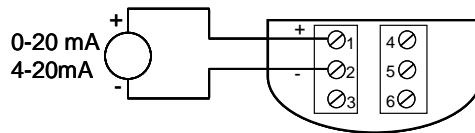

Figure 3-7 Current input wiring

3.3 Universal I/O

STUW700 – Three inputs (1-3) HLAI, (1-2) T/C, (1-2) Discrete Inputs

STUW 701 – Two inputs (1-2) HLAI, T/C, DI + One (1) Discrete Output

Connect wiring

Step	Action
1	See Figure 3-8. Open the rear end cap (opposite end from display) by loosening the M3 locking screw and unscrewing the end cap.
2	Open the cable gland (on right side below antenna). (Cable gland must be ordered as an option.)
3	Feed wiring (allowed diameter 6 to 8 mm) from other transmitter through the cable gland and connect to terminal block using either voltage or current but not both. See wiring diagrams pages 30 and 31.
4	Plug battery connector into batteries.
5	Close rear end cap and cable gland.
6	Tighten M3 locking screw on the rear end cap.

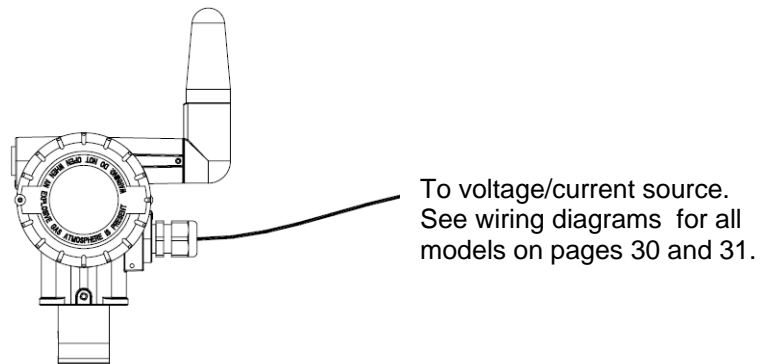
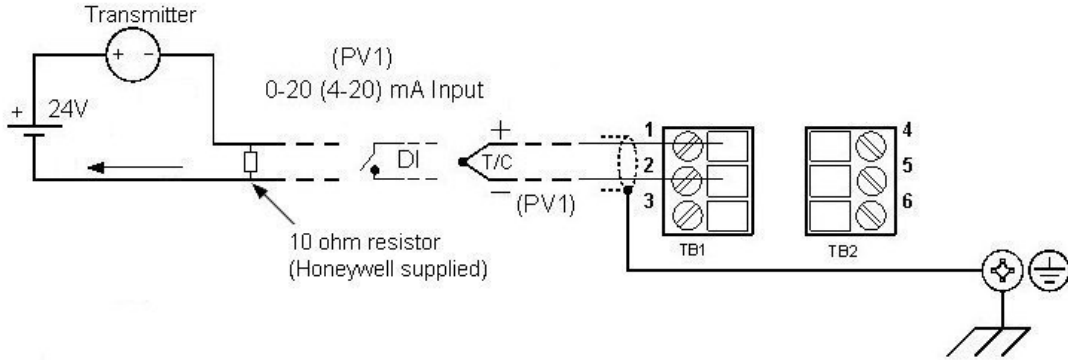

Figure 3-8 Universal I/O Connection

Wiring for calibration – XYR6000 Universal I/O Wiring Diagrams for AI/DI (Model STUW700)

**PV1 Possible Connections
 T/C, DI or HLAI**



**PV2 Possible Connections
 T/C, DI or HLAI**

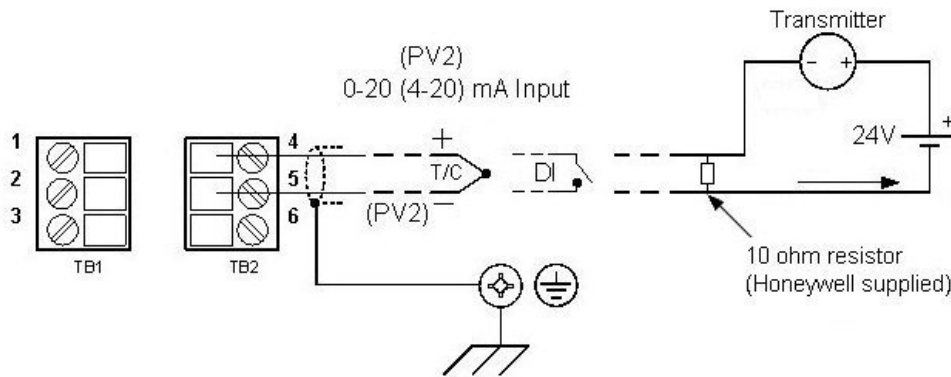

**PV3 Possible Connections
 (HLAI only)**

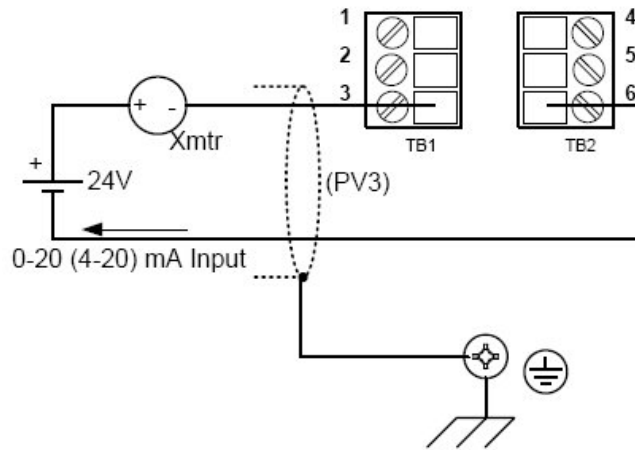

Note: any combination of the above are allowed.
 For example: PV1 is a DI, PV2 is 4-20mA, PV3 is 0-20mA.
 Or PV1 is 0-20mA, PV2 is a T/C, PV3 is 0-20mA

Wiring for calibration – XYR 6000 Universal I/O Wiring Diagrams for AI/DI/DO (Model STUW701)

**PV1 Possible Connections
T/C, DI or HLAI**

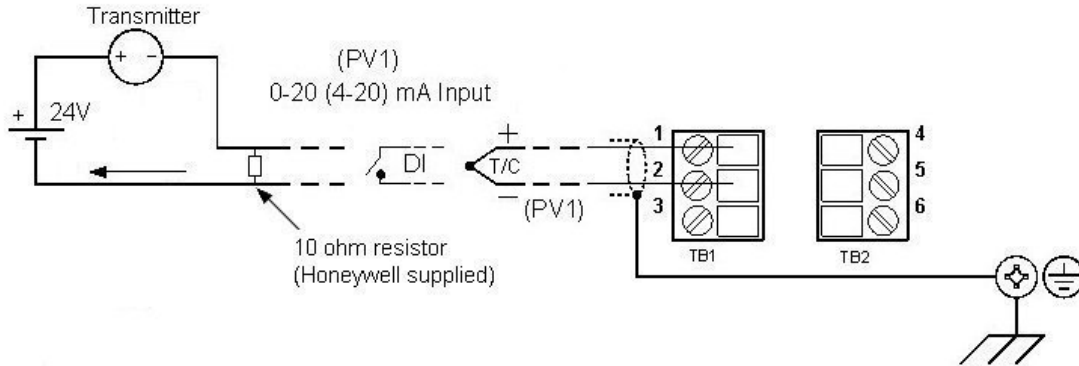

**PV2 Possible Connections
T/C, DI or HLAI**

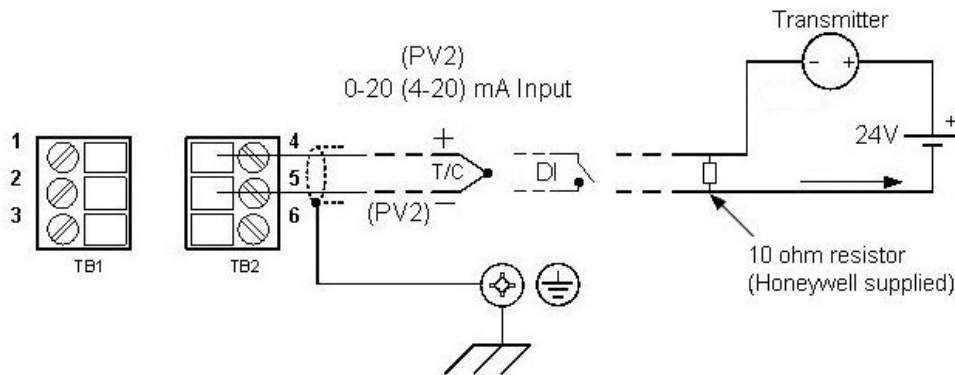

**PV3 Possible Connections
(DO only)**

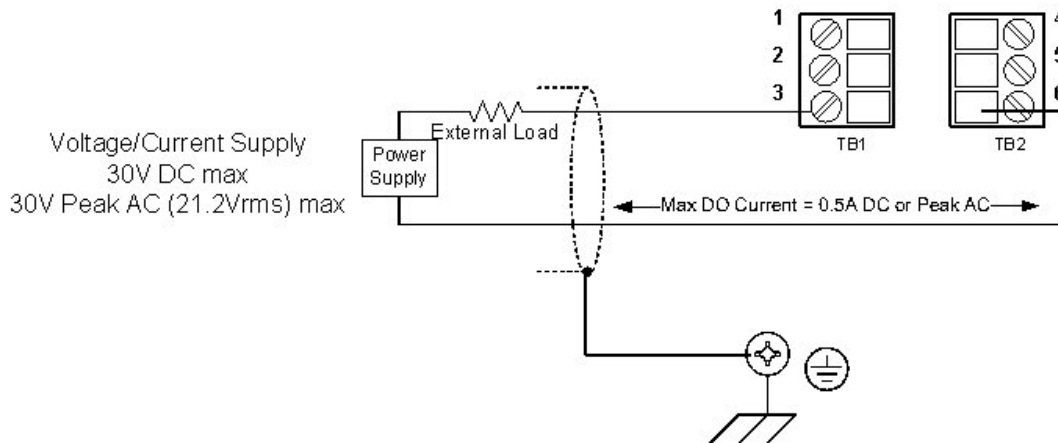

Note: any combination of the above are allowed.
For example: PV1 is a DI, PV2 is 4-20mA, PV3 is DO.
Or PV1 is 4-20mA, PV2 is a T/C, PV3 is DO

STTW 401 T/C AND 2 DI CONNECTION

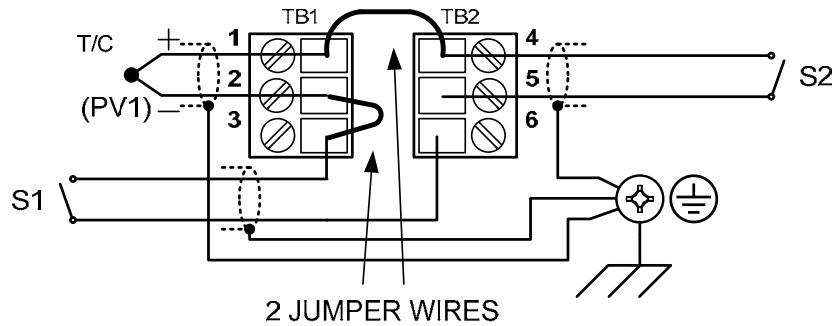

STTW 500 MULTI-DI CONNECTION

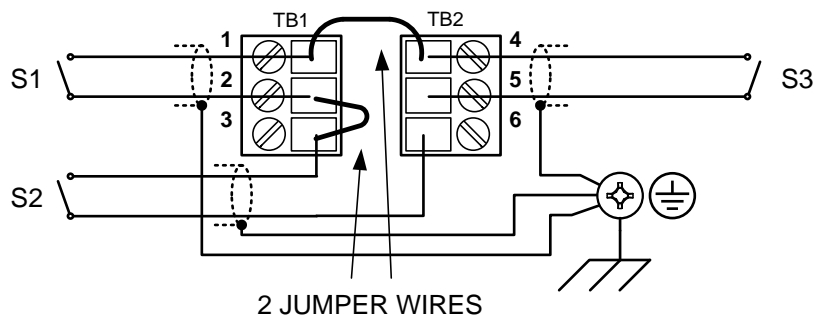

NOTES:

1. Shielded switch input cable is required for EMC conformity and is recommended for all remote switch installations. The shield shall be grounded at the transmitter end only. If the shield is grounded at the switch location, the shield shall not be connected at the transmitter end.
2. Jumper wires the same gauge and stranding as the switch wires are required for all switch input combinations.
3. Switches shall be isolated from each other and from earth ground to avoid common mode noise problems.

3.4 Corrosion models

Probe mounting locations

The corrosion probe must be installed in a location that is most susceptible to corrosion. In most cases, corrosion tends to occur where water is trapped or stagnant. However, it can also accelerate at the bend of the pipe or where corrosion has occurred previously, but is accelerated by high flow or turbulence.

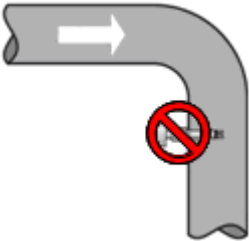
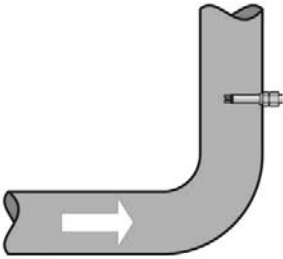
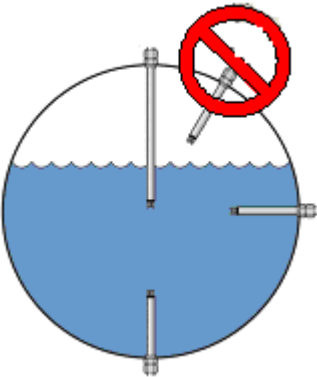
Location	Picture
<p>Incorrect probe location</p> <p>The probe should not be mounted in a pipe drop since the corrosive liquid may not be in full contact with the electrodes.</p>	 <p>The diagram shows a pipe that turns 90 degrees downwards, forming a 'U' shape. A white arrow indicates flow from left to right. A probe is mounted on the vertical section of the pipe, pointing towards the bottom. A red circle with a diagonal slash is superimposed over the probe, indicating that this location is incorrect.</p>
<p>Correct probe location</p> <p>The probe should be mounted in the riser of a pipe near an elbow where the velocity is the highest. In general, probe should be mounted in pipes or tanks at locations of highest liquid velocity and constant immersion.</p>	 <p>The diagram shows a pipe that turns 90 degrees upwards, forming an 'L' shape. A white arrow indicates flow from left to right. A probe is mounted on the horizontal section of the pipe, pointing towards the right. This location is marked as correct.</p>
<p>Correct Pipeline Position</p> <p>Probe can be located at any point on the pipeline but should always be immersed in the corrosive material.</p>	 <p>The diagram shows a circular tank partially filled with blue liquid. Three probes are shown: one at the top (above the liquid level), one at the bottom (fully submerged), and one at the side (fully submerged). A red circle with a diagonal slash is placed over the top probe, indicating it is incorrect. The side and bottom probes are not marked, indicating they are correct.</p>

3. Process Insertion

Corrosion models

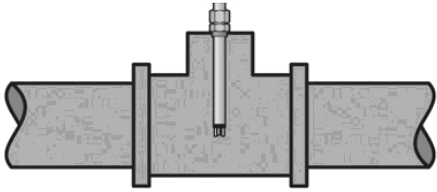
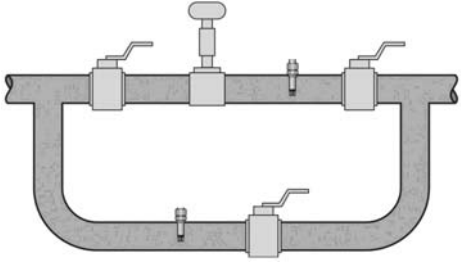
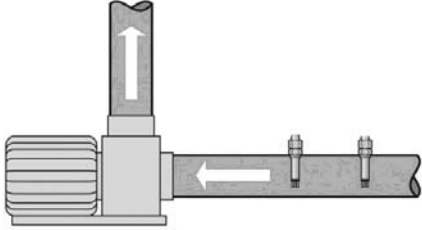
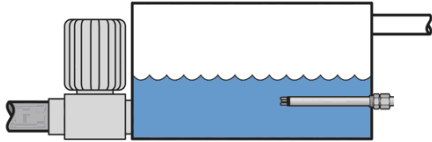
Location	Picture
<p>Located in Tee</p> <p>Probe can be located at any point on the pipeline but should always be immersed in the corrosive material.</p>	
<p>Located in Bypass Loop</p> <p>Probe should be located downstream of a control valve for best performance and can also be located in the deadleg portion of a by-pass.</p> <p>Note that the probe located in the by-pass leg should be mounted before the valve for best performance. This guarantees the electrodes will always be immersed in the corrosive material.</p>	
<p>Mounted with Different Electrodes</p> <p>Installing with different electrode materials on the suction side of the pump will ensure monitoring of the pump impeller and the pipe.</p>	
<p>Installed in a Condensate Flash Tank</p> <p>A condensate flash tank is also a good application.</p>	

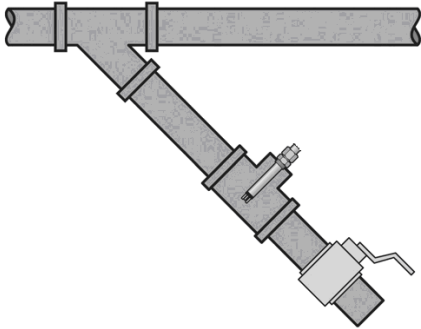
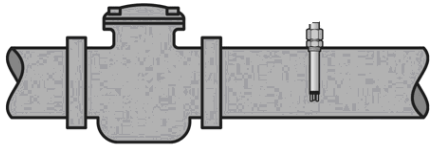
Location	Picture
<p>Mounted in Y-Strainer</p> <p>The probe is shown in the blow down of a Y-strainer.</p>	
<p>Mounted in Basket Strainer</p> <p>The probe is shown in the discharge side of the basket strainer.</p>	

The electrodes should be selected to reflect the same metal properties as the piping or other components that might be susceptible to corrosion. For example, in applications where the pipe is made of stainless steel and the water pump's impeller is made of carbon steel, the impeller will corrode faster than the pipe. In this case it is advisable to select the electrodes to be the same material as the pump's impeller.

Probe installation



WARNING

If the pipe or vessel into which the probe is to be inserted is under pressure and/or contains any hazardous substance, such as steam, caustic solutions, acids, toxins or other substances specified by OSHA as physical or health hazards, the pipe or vessel must first be depressurized and any hazardous substance purged there from, and appropriate lockout/tagout procedures observed in accordance with Section 1910.147 of the OSHA Regulations, before the probe can be installed. Failure to follow these procedures may result in serious injury or death.

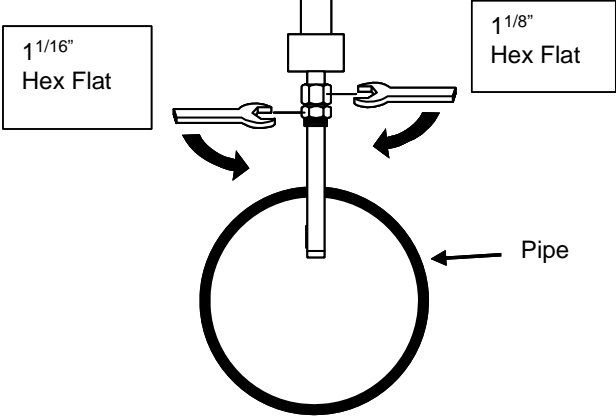
Step	Action
1	<div data-bbox="386 674 998 1087"></div> <p data-bbox="386 1108 1195 1192">Some probes are supplied with an adjustable, compression NPT fitting (e.g. Swagelok). With this fitting, follow this tightening sequence to ensure a tight seal.</p> <ol data-bbox="386 1213 1195 1627" style="list-style-type: none">The Swagelok fitting should be held onto place with a plastic zip-tie around the probe body. The zip-tie should be removed.Determine the depth that the probe should extend into the pipe.Tighten the larger upper nut until the tubing will not rotate freely by hand.Make a mark on the nut. This mark will serve as a reference as the 6 o'clock position.While holding fitting body steady, tighten the large upper nut 1 + 1/4 turns to the 9 o'clock position.This tightening sequence will crimp the internal ring onto the probe body and should lock the fitting in place now.Tighten the lower nut onto the pipe nipple or access point. <p data-bbox="386 1648 1195 1701">For fixed type probes (without the adjustable compression fitting) only the 1 1/16 hex nut needs to be tightened and the safety bracket is not required.</p>
2	<p data-bbox="386 1722 1195 1837">Ensure the flow rate of the process fluid does not exceed 20 feet per second (fps). Stronger flow might damage probes with three finger electrodes and interfere with the reading. If the flow rate exceeds the recommendation, a different probe style may be required.</p>

Connect wiring

Step	Action
1	See Figure 3-9. Open the transmitter's rear end cap (opposite end from display).
2	Open the cable gland (on right side below antenna). (Cable gland must be ordered as an option.)
3	Feed probe wiring through the cable gland and connect to terminal block. See Figure 3-9. For terminal connections see info starting on page 55.
4	Plug battery connector into batteries.
5	Close rear end cap and cable gland.

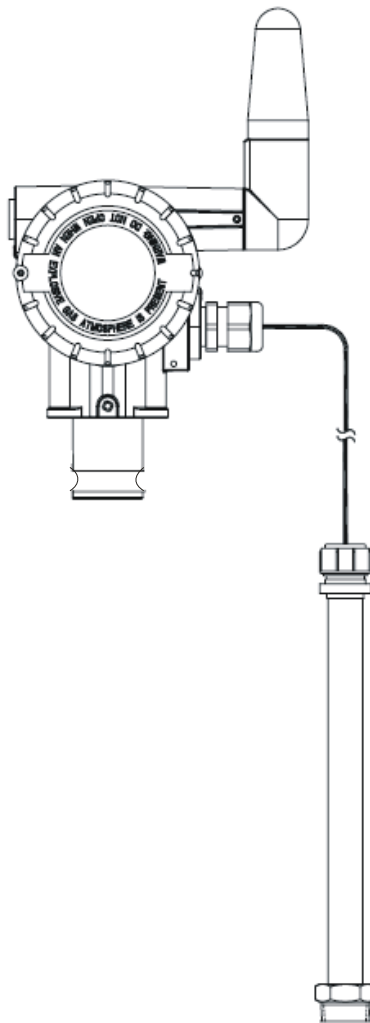

Figure 3-9 Corrosion transmitter with remote probe

4. Antenna adjustment and mounting

4.1 Requirements

Radio installation requirements



ATTENTION

Professional Installation is required to insure conformity with Federal Communications Commission (FCC) in the USA, Industry Canada (IC) in Canada and the Radio and Telecommunications Terminal Equipment Directive, 1999/5/EC (R&TTE), in the European Union (EU).

Professional installation is required for the selection and installation of approved antennas and setup of the maximum allowable radiated power from the XYR 6000 Wireless Transmitter as configured for the particular installation site.

The antenna used for this transmitter must be installed to provide a separation distance of at least 20 cm (8 inches) from all persons and must not be co-located or operating in conjunction with any other antenna or transmitter.

For remote antenna, see antenna installation requirements to satisfy FCC RF exposure requirements.



ATTENTION

Federal Communications Commission (FCC):

The XYR 6000 Wireless Transmitters comply with part 15 of the FCC rules. Operation is subject to the following two conditions: (1) this device may not cause harmful interference, and (2) this device must accept any interference received, including interference that may cause undesired operation.

Industry Canada (IC):

The installer of this radio equipment must ensure that the antenna is located or pointed such that it does not emit RF fields in excess of Health Canada limits for the general population; consult Safety Code 6, obtainable from Health Canada's web site www.hc-sc.gc.ca/rpb.

4.2 Integral antenna



WARNING

POTENTIAL ELECTROSTATIC CHARGING HAZARD

The integrally mounted antenna shroud is made of Teflon® and has a surface resistance greater than 1Gohm per square. When the XYR 6000 transmitter is installed in potentially hazardous locations care should be taken not to electrostatically charge the surface of the antenna shroud by rubbing the surface with a cloth, or cleaning the surface with a solvent. If electrostatically charged, discharge of the antenna shroud to a person or a tool could possibly ignite a surrounding hazardous atmosphere.

Elbow

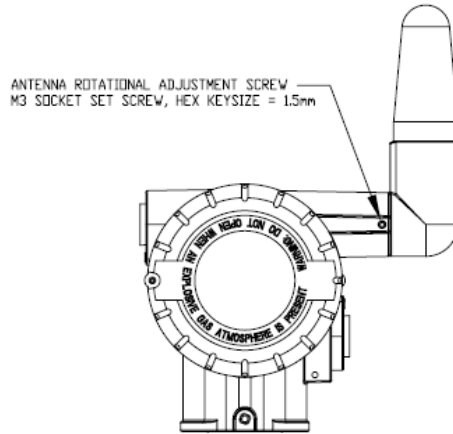

Figure 4-1 Elbow antenna adjustment

(2 dBi Antenna Configuration Shown)

If your model has the integral elbow antenna you can adjust it to improve reception. Typically, pointed straight up gives best performance but your installation may vary. Loosen the 1.5mm set screw located near the antenna base. Rotate antenna for best reception. Do not rotate antenna more than 180 degrees either direction or you could damage internal wiring. Tighten set screw.

Straight

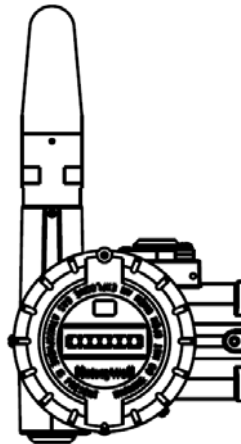

Figure 4-2 Integral straight antenna

(Straight Antenna ONLY available in 2 dBi configuration)

If your model has the integral straight antenna (Figure 4-2) you can adjust its position by rotating the transmitter housing. (See page 20.) Typically, pointed straight up gives best performance but your installation may vary.

4.3 Remote antenna

Outdoor installation warnings



WARNING

LIVES MAY BE AT RISK! Carefully observe these instructions and any special instructions that are included with the equipment you are installing.



WARNING

Contacting power lines can be lethal.

Look over the site before beginning any installation, and anticipate possible hazards, especially these:

Make sure no power lines are anywhere where possible contact can be made. Antennas, masts, towers, guy wires or cables may lean or fall and contact these lines. People may be injured or killed if they are touching or holding any part of equipment when it contacts electric lines. Make sure there is NO possibility that equipment or personnel can come in contact directly or indirectly with power lines.

Assume all overhead lines are power lines.

The horizontal distance from a tower, mast or antenna to the nearest power line should be at least twice the total length of the mast/antenna combination. This will ensure that the mast will not contact power if it falls either during installation or later.



WARNING

To avoid falling, use safe procedures when working at heights above ground.

Select equipment locations that will allow safe, simple equipment installation.

Don't work alone. A friend or co-worker can save your life if an accident happens.

Use approved non-conducting ladders and other safety equipment. Make sure all equipment is in good repair.

If a tower or mast begins falling, don't attempt to catch it. Stand back and let it fall.

If anything such as a wire or mast does come in contact with a power line, DON'T TOUCH IT OR ATTEMPT TO MOVE IT. Instead, save your life by calling the power company.

Don't attempt to erect antennas or towers on windy days.



WARNING

MAKE SURE ALL TOWERS AND MASTS ARE SECURELY GROUNDED, AND ELECTRICAL CABLES CONNECTED TO ANTENNAS HAVE LIGHTNING ARRESTORS. This will help prevent fire damage or human injury in case of lightning, static build-up, or short circuit within equipment connected to the antenna.

The base of the antenna mast or tower must be connected directly to the building protective ground or to one or more approved grounding rods, using 1 OAWG ground wire and corrosion-resistant connectors.

Refer to the National Electrical Code for grounding details.

Lightning arrestors for antenna feed coaxial cables are available from HyperLink Technologies, Inc.



WARNING

If a person comes in contact with electrical power, and cannot move:

DON'T TOUCH THAT PERSON, OR YOU MAY BE ELECTROCUTED.

Use a non-conductive dry board, stick or rope to push or drag them so they no longer are in contact with electrical power.

Once they are no longer contacting electrical power, administer CPR if you are certified, and make sure that emergency medical aid has been requested.

Choosing a Mounting Location

The location of the antenna is important. Objects such as metal columns, walls, etc. will reduce efficiency. Best performance is achieved when antennas for both Multinodes and XYR 6000 Transmitters (Leaf Nodes) are mounted at the same height and in a direct line of sight with no obstructions. If this is not possible and reception is poor, you should try different mounting positions to optimize reception.

Antennas should be mounted clear of any obstructions to the sides of the radiating element. If the mounting location for an omnidirectional antenna is on the side of a building or tower, then the antenna pattern will be degraded on the building or tower side.

Site Selection

Before attempting to install your antenna, think where you can best place the antenna for safety and performance.

Follow these steps to determine a safe distance from wires, power lines, and trees.

Step	Action
1	Measure the height of your antenna.
2	Add this length to the length of your tower or mast and then double this total for the minimum recommended safe distance.



CAUTION

If you are unable to maintain this safe distance, stop and get professional help.

4. Antenna adjustment and mounting

Remote antenna

Generally speaking, the higher your antenna is above the ground, the better it performs. Good practice is to install your antenna about 5 to 10 feet (1.5 to 3 meters) above the roof line and away from all power lines and obstructions. If possible, find a mounting place directly above your wireless device so that the lead-in cable can be as direct as possible.

Mounting the Antenna

Antennas are provided with a mast mounting kit consisting of a mounting bracket and two U-bolt clamps. This kit allows you to mount the antenna to masts with outside diameters (O.D.) from 1.25 inches (3.2 centimeters) to 2 inches (5.1 centimeters). Honeywell recommends that a 1.5 inch (3.8 centimeter) or larger tubing mast be used.

Omnidirectional antennas are vertically polarized. It is very important to mount the antenna in a vertical (not leaning) position for optimal performance.

Follow these steps to mount the antenna on a mast.

Step	Action
1	Assemble your new antenna on the ground at the installation site. See the instructions on the following pages for your type of antenna.
2	Attach the antenna to the mast and connect its coaxial cable while you are on the ground, using the mounting kit provided with the antenna. Tighten cables by hand only; do not use tools or you could overtighten. After the cable is attached to the antenna, make sure that the connections are sealed (if outdoors) to prevent moisture and other weathering elements from affecting performance. Honeywell recommends using a weathering tape (such as Coax-Seal [®]) for outdoor connections. Silicon sealant or electrical tape is not recommended for sealing outdoor connections.
3	Using tie-wraps (cable ties), secure the coax cable to the mast, using a tie-wrap every ten to twelve inches (25 to 30 cm).
4	Follow standard strain relief practice when installing the antenna cable. Avoid excessive strain, bending, kinks, or crushing (stepping on or placing any weight on cable) before, during or after the coax cable is secured in its final position.
5	Make sure the mast does not fall the "wrong way" should you lose control as you raise or take down the mast. Use a durable non-conductive rope. Have an assistant tend to the rope; ready to pull the mast clear of any hazards (such as power lines) should it begin to fall.
6	If the installation will use guy wires: <ul style="list-style-type: none">• Install guy anchor bolts.• Estimate the length of guy wire and cut it before raising the mast.• Attach guy wires to a mast using guy rings.
7	Carefully connect the antenna and mast assembly to its mounting bracket and tighten the clamp bolts. In the case of a guyed installation, you must have at least one assistant to hold the mast upright while the guy wires are attached and tightened to the anchor bolts.
8	Attach the provided self-adhering "DANGER" label at eye level on the mast.
9	Install ground rods to remove any static electricity buildup and connect a ground wire to the mast and ground rod. Use ground rods designed for that purpose; do not use a spare piece of pipe.

Step	Action
10	When attaching the coax cable to the XYR 6000, it is recommended that a drip loop with a radius of at least 12 inches (30 cm) be formed close to the XYR 6000. This will minimize ice and water buildup on the transmitter itself. Tighten cables by hand only; do not use tools or you could overtighten.

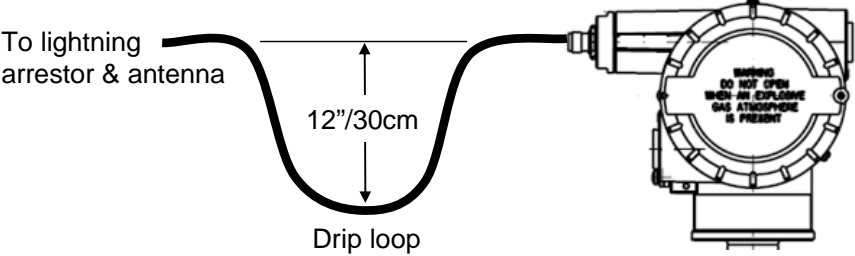

The diagram illustrates the correct installation of a coaxial cable. On the right, the XYR 6000 transmitter is shown with a warning label that reads: "WARNING DO NOT OPEN WHEN AN EXPLOSIVE GAS ATMOSPHERE IS PRESENT". A coaxial cable is connected to the transmitter and is looped back to form a "Drip loop" with a radius of 12 inches (30 cm). The cable then continues to the left, labeled "To lightning arrester & antenna".

4. Antenna adjustment and mounting
Remote antenna

Directional mounting procedure

Step	Action
1	Secure mast mounting bracket to mast as shown using 2 U-bolts and supplied hardware.
2	Attach antenna to mast mounting bracket as shown using supplied hardware.
3	Adjust antenna to desired tilt and lock into place using the antenna tilt adjustment nut.



Figure 4-3 Directional antenna mounting

Omnidirectional mounting procedure

Step	Action
1	Secure mast mounting bracket to mast as shown using 2 U-bolts and supplied hardware.
2	Remove antenna mounting bolt and washer from antenna base.
3	Insert antenna into mounting bracket and secure with washer and antenna mounting bolt. Do not overtighten.
4	Any drain holes in the antenna base must be kept clear for proper operation.



Figure 4-4 Omnidirection antenna mounting

Grounding the antenna

Follow these guidelines to ground the antenna in accordance with national electrical code instructions.

Step	Action
1	Use No. 10 AWG copper or No. 8 or larger copper-clad steel or bronze wire as ground wires for both mast and lead-in. Securely clamp the wire to the bottom of the mast.
2	Secure the lead-in wire to a lightning arrester and mast ground wire to the building with stand-off insulators spaced from 4 feet (1.2 meters) to 8 feet (1.8 meters) apart.

4. Antenna adjustment and mounting

Remote antenna

Step	Action
3	<p>Using coaxial cable, connect the antenna base to the transmitter's remote antenna connector (located at top right as you face the transmitter display). Antenna cable shield is bonded to earth ground via either the transmitter earth ground connection and/or by the lightning arrester earth ground connection. The lightning arrester must be bonded to earth ground in order to function properly. Tighten cables by hand only; do not use tools or you could overtighten.</p> <p>See pages Error! Bookmark not defined., Error! Bookmark not defined., Error! Bookmark not defined. and Error! Bookmark not defined. for cable types and connection information.</p>
4	<p>If the coax cable is to enter a building, then the lightning arrester should be mounted as close as possible to where the lead-in wire enters the building. The lightning arrester sold by Honeywell features a bulkhead N-Female connector with a rubber "O"-ring seal which can be used for mounting through an enclosure wall. The lightning arrester can also be mounted using the included stainless steel mounting bracket. Both connector ports of the lightning arrester provide equal protection no matter which way it is installed. Either port can face the antenna and either port can face the Transmitter.</p>
5	<p>Drill a hole in the building's wall as close as possible to the equipment to which you will connect the lead-in cable.</p>



CAUTION

There may be wires in the wall. Before drilling check that the area is clear of any obstructions or other hazards.

- 6 Pull the cable through the hole and form a drip loop on the outside close to where the cable enters the building. The drip loop should have a radius of at least 12 inches (30 cm).

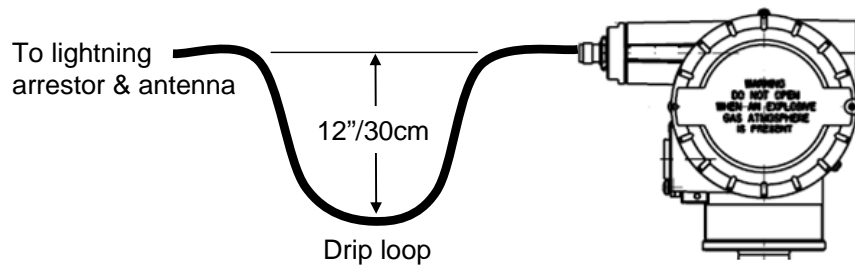

- 7 Thoroughly waterproof the lead-in area.
- 8 Connect the lead-in cable to the XYR 6000 Transmitter. Tighten cables by hand only; do not use tools or you could overtighten.
-

5. Start up

5.1 Battery Power Option

Connect batteries



WARNING

- Risk of death or serious injury from explosion or fire.
 - If IS Battery Pack, Honeywell 50047517-501, has been installed in the Wireless Transmitter, the transmitter enclosure maybe opened when an explosive gas atmosphere is present. Otherwise, do not open transmitter enclosure when and explosive gas atmosphere is present.
 - When not in use the Battery Pack must be stored in a non Hazardous Area
 - Do not change batteries in an explosive gas atmosphere.
 - The batteries used in this device may present a risk of fire or chemical burn if mistreated. Do not recharge, disassemble, heat above 100°C (212°F), or incinerate.
 - When installing batteries, do not snag the battery terminal on the clip or the battery may be damaged. Do not apply excessive force.
 - Do not drop. Dropping the battery may cause damage. If a battery is dropped, do not install the dropped battery into the transmitter. Dispose of dropped battery promptly per local regulations or per the battery manufacturer's recommendations.
-



ATTENTION

Both batteries must be the same model from the same manufacturer. Mixing old and new batteries or different manufacturers is not permitted.

Use only the following 3.6V lithium thionyl chloride (Li-SOCI₂) batteries (non-rechargeable), size D. No other batteries are approved for use in XYR 6000 Wireless Transmitters.

- Xeno Energy XL-205F
 - Eagle Picher PT-2300H
 - Tadiran TL-5930/s
 - Tadiran GmbH, SL-2780
 - Honeywell p/n 50026010-501 (Two 3.6V lithium thionyl chloride batteries)
 - Honeywell p/n 50026010-502 (Four 3.6V lithium thionyl chloride batteries)
 - Honeywell p/n 50026010-503 (Ten 3.6V lithium thionyl chloride batteries)
-

5. Start up

Battery Power Option

These instructions are divided into two procedures for:

- [IS Battery Holder, 50025288-502](#)
- [IS Battery Pack, 50047517-501](#)

Tools required

- #1 Phillips Screwdriver or 1/8" Slotted Screwdriver
- Torque Screwdriver
- 1.5 mm hex key

Procedure

It is the User/Installer's responsibility to install the XYR 6000 Wireless Transmitters in accordance with national and local code requirements.

IS Battery Holder, 50025288-502

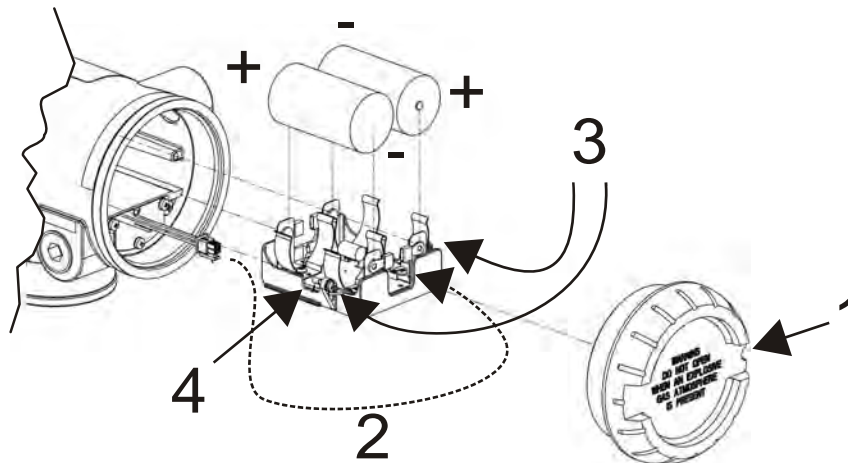



Figure 5-1: Battery assembly

Battery replacement procedure

Step	Action
1	Loosen the M3 locking set screw on the battery end-cap (opposite end from display). See item 1 in Figure 5-1. Unscrew and remove the end cap.
2	Using thumb and forefinger, squeeze the battery connector at top and bottom to disengage the locking mechanism, then pull to disconnect. See item 2 in Figure 5-1.
3	Loosen the two battery holder retaining screws (closest to the batteries). See item 3 in Figure 5-1. The screws are captive.
4	Pull the battery holder out of the transmitter.
5	Remove the old batteries from the battery holder. If needed, pry out the batteries by using a slotted screwdriver as a lever in the holder's side slots. See item 4 in Figure 5-1.
6	<p>Install batteries as follows to avoid snagging the battery terminal on the clip and damaging the battery.</p> <p>Align the new battery with the clips and angle the positive end of the battery into the positive battery terminal clip. Using a thumb and forefinger pull the negative terminal clip outward and push down on the battery until fully seated in the clips. Do not apply excessive force when pushing battery down.</p> <p>Repeat this process for the second battery.</p>
7	<p>Insert the battery holder into the transmitter. Reattach the screws and tighten to 0.4 – 0.6 N-M (3.5 – 5.3 Lb-in).</p> <p>Re-connect battery connector.</p> <p>Honeywell recommends lubricating the end cap O-ring with a Silicone Grease such as Dow Corning #55 or equivalent before replacing the end cap.</p>
8	Screw the end cap back on and tighten the M3 locking screw.
9	Dispose of used battery promptly per local regulations or the battery manufacturer's recommendations. Keep away from children. Do not disassemble and do not dispose of in fire.

IS Battery Pack, 50047517-501

IS Battery Pack replacement procedure

Step	Action
1	Follow steps 1-4, as above
2	WARNING  DO NOT ASSEMBLE/DISASSEMBLE WHEN AN EXPLOSIVE ATMOSPHERE IS PRESENT

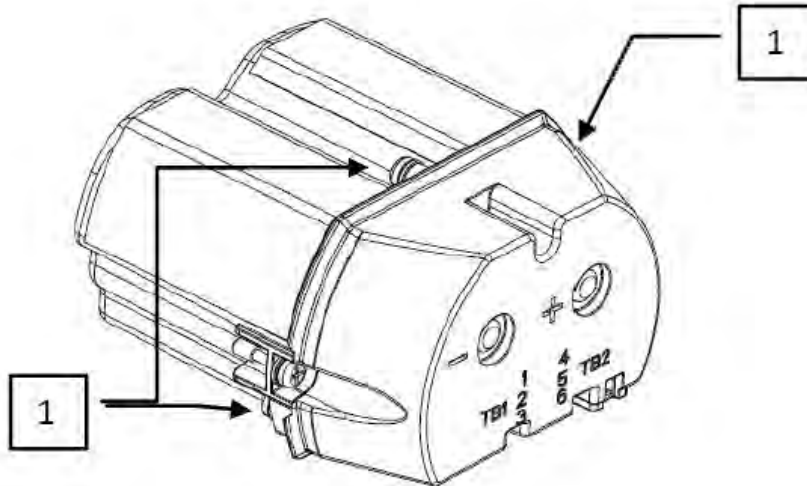

Figure 5-2: IS Battery Pack

- 3 Remove top of battery pack by using a #1 Philips or 1/8" slotted screwdriver for the screws identified as #1 in Figure 5-2.
- 4 Remove the spent batteries and dispose of them promptly according to local regulations of the battery manufacturer's recommendations.
- 5 Install the batteries following the polarity as noted on the lid
- 6 Re-install top of the battery pack and tighten screws
- 7 Insert the Battery pack into the transmitter. Re-attach the screws as indicated in Figure 5-1, item 3, to 0.4 to 0.6 N-M (3.5 – 5.3 Lb-in).
Reconnect the Battery Pack connector
Honeywell recommends lubricating the end cap threads with a silicone grease such as Dow Corning #55 or equivalent before replacing the end cap
- 8 Screw the cap back on and tighten the M3 locking screw

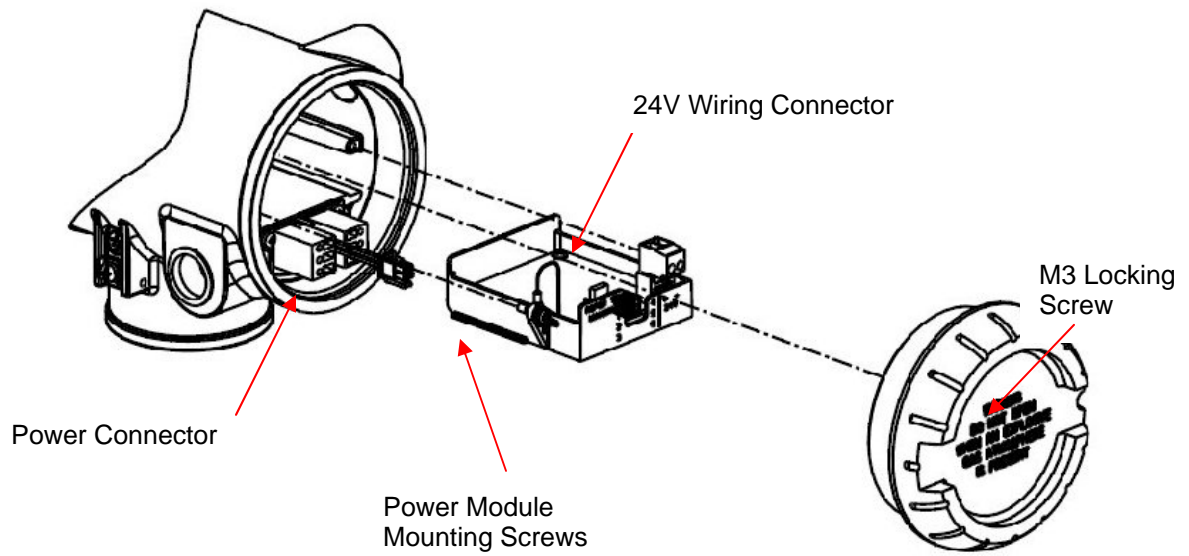

Figure 5-3 Power Option 24V

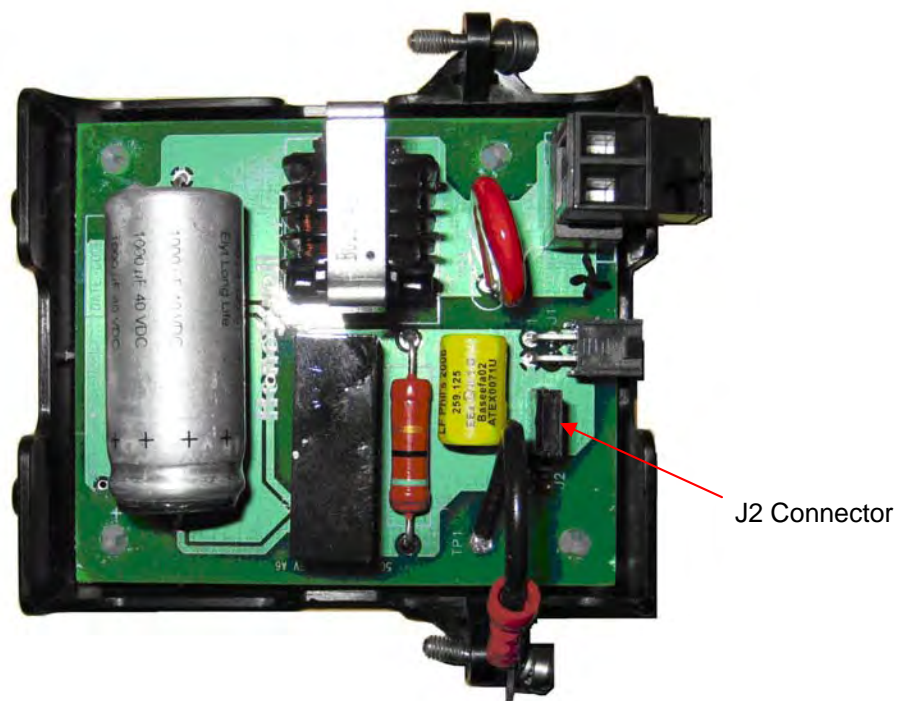

Figure 5-4 External 24V Power Module

24 Vdc Power Supply Option (DC) System Diagram

(Ordinary Non-Hazardous Locations)

24Vdc POWER SUPPLY OPTION (DC) SYSTEM DIAGRAM
(ORDINARY NON-HAZARDOUS LOCATIONS)

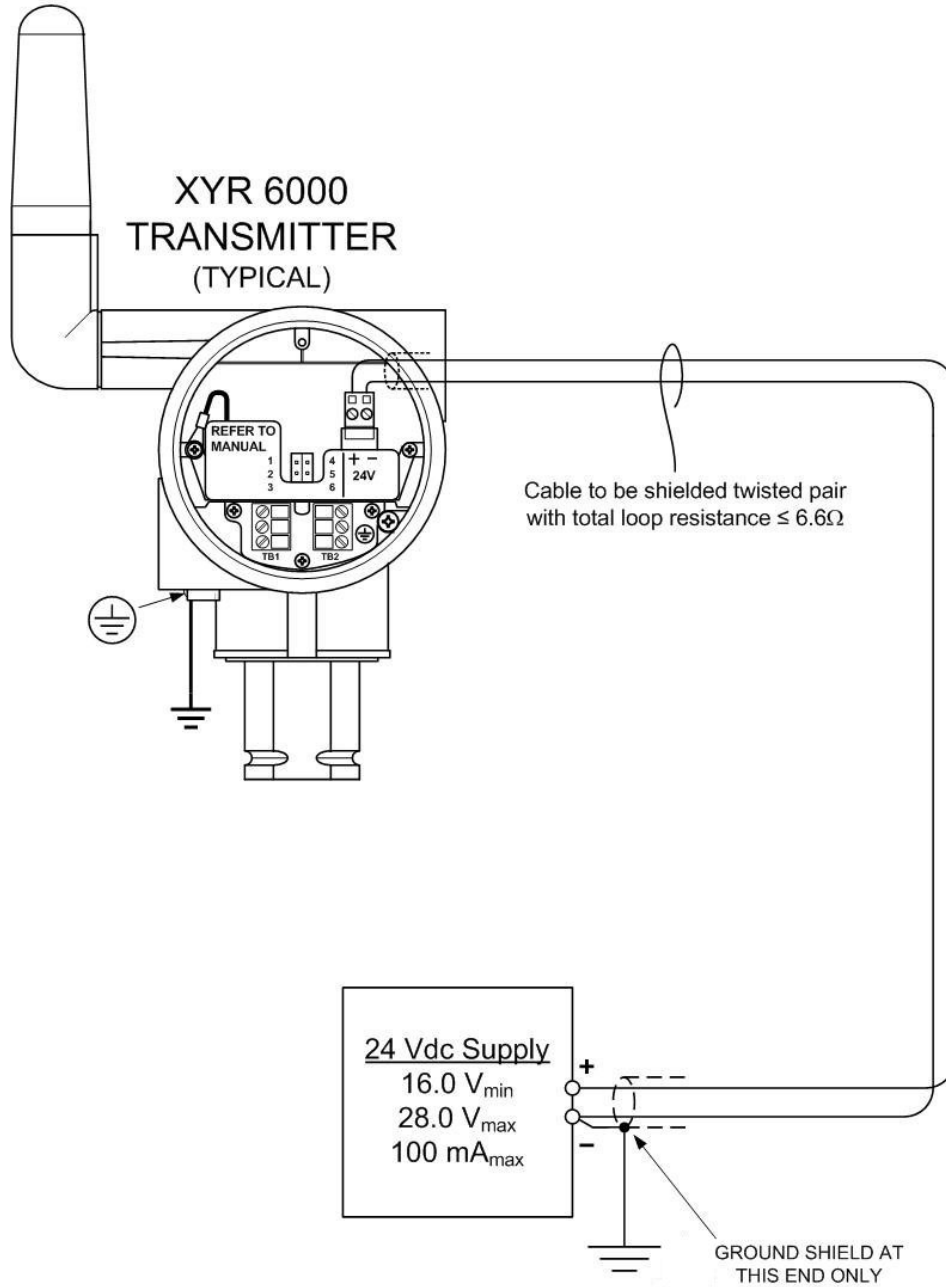

Figure 5-5 Power Supply 24 Vdc Option (DC) System Diagram

5.2 Display sequence

After power up, the transmitter does a brief self-test of the LCD display. Then it proceeds to Power-On Message, which is the model name of the transmitter. The name is displayed for 2 seconds after which the transmitter displays the process variables and associated status.

5.3 Provisioning

Before the transmitter can be configured it must be unlocked with a security key so it can join the network. Use the Provisioning Device Pocket PC software to receive security keys from the Key Server manager, then aim the Pocket PC at the transmitter and transmit a key.

Transmitters in the OneWireless Network with R210 release software can be provisioned using over-the-air provisioning.

The Wireless Device Manager (WDM) provisions the access points, and the access points that are enabled to function as provisioning devices can then provision the transmitters. To enable the over-the-air provisioning capability, you must first enable this feature in the Onewireless User Interface. For more information, please reference the OW R210 Wireless Device Manager User's Guide (OW-CC0020).

See Getting Started with Honeywell OneWireless Solutions for more information.

6. Certification Installation Requirements



6.1 Certification Drawings

Use the following drawings and accompanying notes and text for hazardous locations. **Any deviation from the installation requirements could void the certification.** For non-hazardous locations you can use the same drawings without the accompanying notes and text.

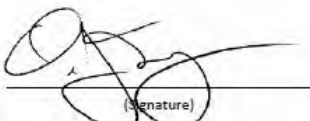
EC Declaration of Conformity

	
EC Declaration of Conformity	
51453837 Issue B1	
PRODUCT:	XYR 6000 Wireless Transmitters
MANUFACTURE:	Honeywell International Inc. Honeywell Field Solutions 512 Virginia Drive Fort Washington, PA 19034 United States of America
To which this declaration relates, is in conformity with the provisions of the European Community Directives, including the latest amendments as shown on the attached schedule.	
Assumption of conformity is based on the application of the harmonized standards and when applicable and required, a European Community notified body certification, as shown in the attached schedule.	
 (Signature)	
Owen Murphy Product Safety and Approvals Engineer	
16 February 2012 (Date)	

Schedule



Schedule

50061463 Issue B1

EMC Directive (2004/108/EC)
EN 61326-1: 2006

R&TTE Directive (1999/5/EC)
Emissions Specification and Method: EN 300 328 V1.7.1
Emissions Spec and Method: EN 301 893 V1.3.1
Immunity Specification: EN 301 489-17 V1.2.1
Immunity Method: EN 301 489-1 V1.6.1

NORTHWEST EMC Inc. [Notified body Number: 0981]
22975 N.W. Evergreen Parkway #400
Hillsboro, Oregon 97124
United States

ATEX Directive (94/9/EC)

Intrinsically Safe:

EC-TYPE Certificate: KEMA 08ATEX0062 X
Protection: Intrinsically Safe, "i" and Dust tD

Standard	Year	Title
EN 60079-0	2006	Apparatus for Explosive Gas Atmospheres – General Requirements
EN 60079-11	2007	Electrical Apparatus for Explosive Gas Atmospheres – Intrinsic Safety
EN 60079-26	2007	Explosive atmospheres – Part 26: Equipment with equipment protection level (EPL) Ga
EN 61241-0	2007	Electrical apparatus for use in the presence of combustible dust – Part 0: General requirements
EN 61241-1	2004	Electrical apparatus for use in the presence of combustible dust – Part 1: Protection by enclosures "tD"



Schedule

50061463 Issue B1

Flame-Proof:

EC-TYPE Certificate: KEMA 08ATEX0062 X

Protection: Intrinsically Safe, "d" and Dust tD

Standard	Year	Title
EN 60079-0	2006	Apparatus for Explosive Gas Atmospheres – General Requirements
EN 60079-1	2004	Electrical Apparatus for Explosive Atmospheres – Part 15: Equipment protection by type of protection "n"
EN 61241-0	2007	Electrical apparatus for use in the presence of combustible dust – Part 0: General requirements
EN 61241-1	2004	Electrical apparatus for use in the presence of combustible dust – Part 1: Protection by enclosures "tD"

Production Quality Assurance Notification

DEKRA Certification Inc. (Notified body Number: 0344)

Utrechtseweg 310

6812 AR Arnhem

The Netherlands

Non -Sparking:

EC-TYPE Certificate: KEMA 08ATEX0074

Protection: Non Sparking, Zone 2, "n" and Dust tD

Standard	Year	Title
EN 60079-0	2006	Apparatus for Explosive Gas Atmospheres – General Requirements
EN 60079-15	2005	Electrical Apparatus for Explosive Atmospheres – Part 15: Equipment protection by type of protection "n"
EN 61241-0	2007	Electrical apparatus for use in the presence of combustible dust – Part 0: General requirements
EN 61241-1	2004	Electrical apparatus for use in the presence of combustible dust – Part 1: Protection by enclosures "tD"

CSA Installation Drawings

COPYRIGHT 2012, HONEYWELL INTERNATIONAL INC. NEITHER THIS DOCUMENT NOR THE INFORMATION CONTAINED HEREIN SHALL BE REPRODUCED, USED OR DISCLOSED TO OTHERS WITHOUT THE WRITTEN AUTHORIZATION OF HONEYWELL. USE, DUPLICATION, OR DISCLOSURE OF THIS DOCUMENT IS SUBJECT TO THE RESTRICTIONS SET FORTH IN A WRITTEN AGREEMENT. NOTHING CONTAINED HEREIN SHALL BE CONSTRUED AS CONFERRING BY IMPLICATION, ESTOPPEL, OR OTHERWISE ANY LICENSE TO ANY PATENT, TRADEMARK, COPYRIGHT OR OTHER INTELLECTUAL PROPERTY RIGHT OF HONEYWELL OR ANY THIRD PARTY.	ISS	REVISION & DATE	APPD
	F	26 March 2012 ECO-0069377	VM

XYR 6000 WIRELESS TRANSMITTERS

CSA CERTIFIED & FM APPROVED DIVISION 2 / ZONE 2

INSTALLATION DRAWING

NOTES:

1. Division 2 / Zone 2 installation shall be in accordance with the Canadian Electrical Code (CEC), part I, Section 18 for Canada, ANSI/NFPA 70, NEC® Articles 501-4(b) or 505-15(c) for the USA and ANSI/ISA 12.12.01.
2. System Parameters:
 XYR 6000 and Field Transmitter $V_{max} \geq V_{oc}$ or U_o , $I_{max} \geq I_{sc}$ or I_o ;
 XYR 6000 C_i + Field Transmitter C_i + $C_{cable} \leq$ Control Apparatus C_a ,
 XYR 6000 L_i + Field Transmitter L_i + $L_{cable} \leq$ Control Apparatus L_a .
3. When the electrical parameters of the cable are unknown, the following values may be used: Capacitance – 197pF/m (60 pF/ft), Inductance – 0.66µH/m (0.020 µH/ft).
4. For Class II and Class III installations and Type 4X / IP66 applications where rigid metal conduit is not used, seal all cable and unused entries against dust and fibers using a NRTL listed cable gland or seal fitting.
5. Transmitters shall have the enclosure bonded to ground in accordance with CEC part I, Section 18-074, Bonding in hazardous locations, and Rule 10-814.
6. Shielded two-wire cable is required for EMC conformity and is recommended for all installations. The 4-20 mA loop shield shall be grounded at the supply end ONLY.
7. Division 2: WARNING: EXPLOSION HAZARD – DO NOT DISCONNECT EQUIPMENT UNLESS POWER HAS BEEN SWITCHED OFF OR THE AREA IS KNOWN TO BE NON-HAZARDOUS.
8. NO REVISION OF THIS INSTALLATION DRAWING IS PERMITTED WITHOUT AUTHORIZATION FROM CSA AND FM APPROVALS.
9. For release approvals see ECO # 0031900.

CERTIFICATION DOCUMENT ENGINEERING CHANGE ORDERS (ECOs) MUST BE AUTHORIZED BY APPROVALS ENGINEERING MASTER FILE TYPE: MS WORD	DRAWN	WF		Honeywell		
	CHECKED			CSA Installation Drawing		
	DEV ENG	NOTE 9		XYR 6000 Wireless Transmitters		
	MFG ENG			Division 2 / Zone 2		
	QA ENG			A	50026071	
TOLERANCE UNLESS NOTED				A4		
ANGULAR DIMENSION				SCALE	USED ON	SH.1 OF 11

CSA CERTIFIED DIVISION 2 / ZONE 2
 INSTALLATION DRAWING – TWO-WIRE CONFIGURATION

XYR 6000, STIW600, 0–20 mA / 4–20 mA HIGH LEVEL INPUT INTERFACE

NON-HAZARDOUS LOCATION

CONTROL APPARATUS
 NON-INCENDIVE FIELD
 WIRING PARAMETERS

U_o (V_{oc} or V_t) \leq 30 V
 I_o (I_{sc} or I_t) \leq 125 mA
 $P_o \leq$ 1.0 W
 $C_a \geq C_{cable} + C_{Field\ Transmitter} + 6.8\ nF$
 $L_a \geq L_{cable} + L_{Field\ Transmitter} + 1.0\ \mu H$

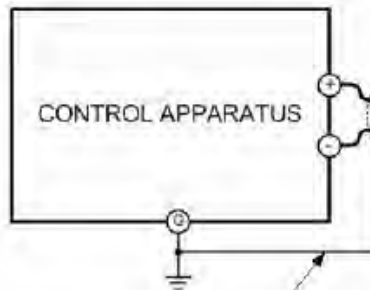

6
 GROUND SHIELD AT
 THIS END ONLY

HAZARDOUS (CLASSIFIED) LOCATION

XYR 6000 WIRELESS TRANSMITTER
 CLASS I, DIV 2, GROUPS A,B,C,D;
 CLASS II, DIV 2, GROUPS F & G, CLASS III, DIV 2, T4;
 CLASS I, ZONE 2, Ex / AEx nA GROUP IIC, T4
 AMBIENT LIMITS: $-40 \leq T_a \leq 85^\circ C$
 ($\leq 80^\circ C$ WITH OPTION DC)

NON-INCENDIVE FIELD
 WIRING PARAMETERS
 U_i (V_{max}) = 30 V
 I_i (I_{max}) = 125 mA
 $P_i = 1.0\ W$
 $C_i = 6.8\ nF$
 $L_i = 1.0\ \mu H$

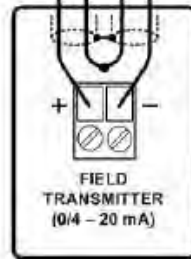
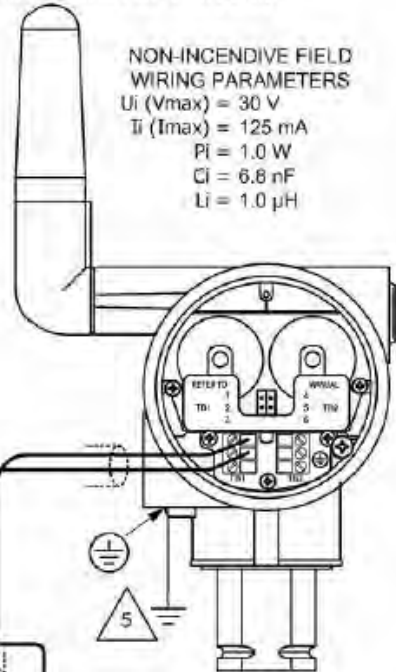

FIELD TRANSMITTER
 CSA CERTIFIED FOR USE IN
 CLASS I, II, DIV 2 / ZONE 2 /
 FM APPROVED FOR USE IN
 CLASS I, II, DIV 2 / ZONE 2

Honeywell

A/A4

50026071

SCALE NONE

REV F

DATE 26 March 2012

SH. 2 of 11

**WIRELESS TEMPERATURE AND DIGITAL INPUT (DI) TRANSMITTERS
 STTW400, STTW401, STXW500, STT820, STTW830 & STTW840**

HAZARDOUS (CLASSIFIED) LOCATION

CLASS I, DIV 2, GROUPS A, B, C, D; CLASS II DIV 2, GROUPS F & G, CLASS III, DIV 2, T4;
 CLASS I, ZONE 2 Ex/AEx nA GROUP II, T4;
 AMBIENT LIMITS: $-40 < T_a < 85^{\circ}\text{C}$ ($< 80^{\circ}\text{C}$ WITH OPTION DC)

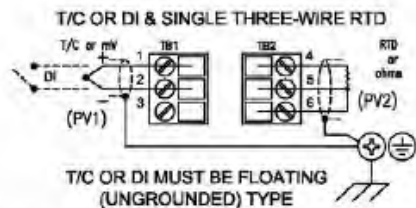
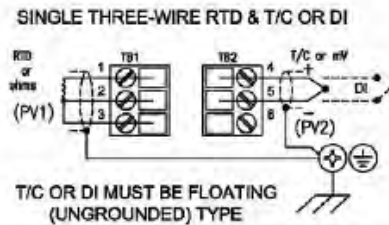
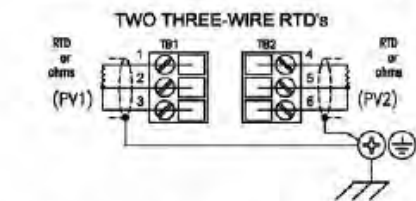
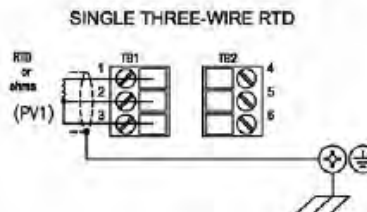
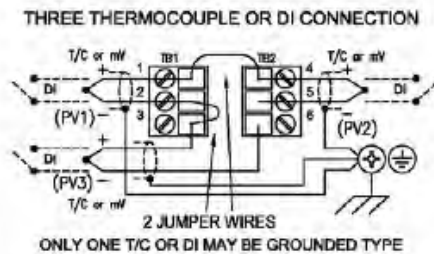
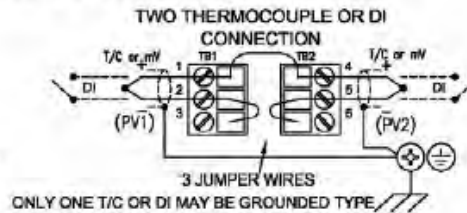
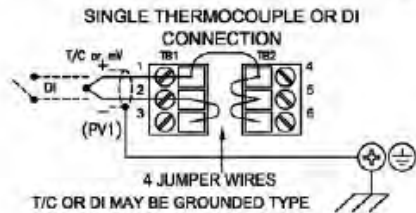

IS FIELD WIRING PARAMETERS

WITH OPTION DC
 $C_a = 2.7 \mu\text{F} \geq C_{\text{Cable}}$
 $L_a = 100 \text{ mH} \geq L_{\text{Cable}}$

WITH OPTION BA
 $C_a = 9.3 \mu\text{F} \geq C_{\text{Cable}}$
 $L_a = 100 \text{ mH} \geq L_{\text{Cable}}$

NOTES:

1. Shielded thermocouple/mV or RTD/Ohms cable is required for EMC conformity and is recommended for all remote sensor installations. The shield shall be grounded at the transmitter end only.
2. When remote mounted probe sensors are used and the shield is grounded at the probe, the shield shall not be connected at the transmitter end.
3. Duplex (redundant) sensors that are bonded to the probe are not permitted. All thermocouple/mV inputs and RTD/Ohms inputs must be insulated from ground (the probe) and from each other as noted above.
4. Jumper wires the same gauge and stranding as the thermocouple wires are required for single and dual thermocouple input combinations.
5. Digital input switches, DI, must be dry contact type, simple apparatus and properly segregated from all other sources of power.

Honeywell	A/A4	50026071		
	SCALE NONE	REV F	DATE 26 March 2012	SH. 3 of 11

**WIRELESS TEMPERATURE AND DIGITAL INPUT (DI) TRANSMITTERS
 STTW400, STTW401, STXW500, STTW820, STTW830 & STTW840**

HAZARDOUS (CLASSIFIED) LOCATION

CLASS I, DIV 1, GROUPS A, B, C, D; CLASS II DIV 1, GROUPS E, F & G, CLASS III, DIV 1, T4;
 CLASS I, ZONE 0 Ex/AEx ia GROUP IIC, T4;
 AMBIENT LIMITS: $-40 < T_a < 85^{\circ}\text{C}$ ($< 80^{\circ}\text{C}$ WITH OPTION DC)

SINGLE TWO-WIRE RTD

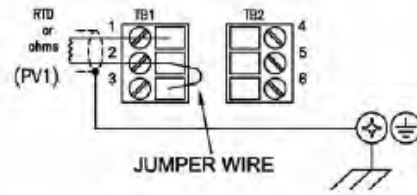

TWO TWO-WIRE RTD

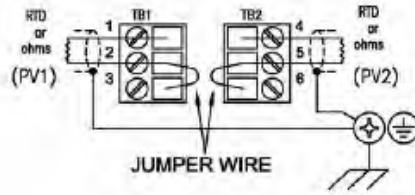

T/C OR DI & SINGLE TWO-WIRE RTD

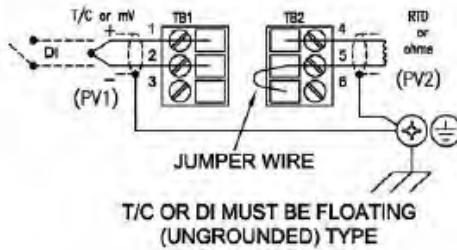

SINGLE TWO-WIRE RTD & T/C OR DI

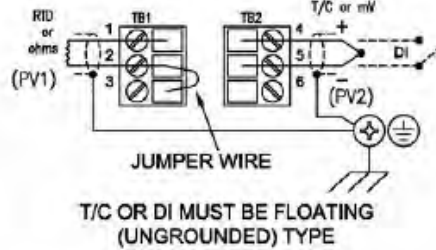

IS FIELD WIRING PARAMETERS

WITH OPTION DC
 $C_a = 2.7 \mu\text{F} \geq C_{\text{Cable}}$
 $L_a = 100 \text{ mH} \geq L_{\text{Cable}}$

WITH OPTION BA
 $C_a = 9.3 \mu\text{F} \geq C_{\text{Cable}}$
 $L_a = 100 \text{ mH} \geq L_{\text{Cable}}$

NOTES:

1. Shielded thermocouple/mV or RTD/Ohms cable is required for EMC conformity and is recommended for all remote sensor installations. The shield shall be grounded at the transmitter end only.
2. When remote mounted probe sensors are used and the shield is grounded at the probe, the shield shall not be connected at the transmitter end.
3. Duplex (redundant) sensors that are bonded to the probe are not permitted. All thermocouple/mV inputs and RTD/Ohms inputs must be insulated from ground (the probe) and from each other as noted above.
4. Jumper wires the same gauge and stranding as the thermocouple wires are required for single and dual thermocouple input combinations.
5. Digital input switches, DI, must be dry contact type, simple apparatus and properly segregated from all other sources of power.

Honeywell	A/A4	50026071		
	SCALE NONE	REV F	DATE 26 March 2012	SH. 4 of 11

WIRELESS UNIVERSAL I/O - STUW700 & STUW701

HAZARDOUS (CLASSIFIED) LOCATION

CLASS I, DIV 2, GROUPS A,B,C,D; CLASS II, DIV 2, GROUPS F & G, CLASS III, DIV 2, T4;

CLASS I, ZONE 2, Ex / AEx nA GROUP IIC, T4; AMBIENT LIMITS: $-40 \leq T_a \leq 85^\circ\text{C}$
 ($\leq 80^\circ\text{C}$ WITH OPTION DC)

STUW700 - POSSIBLE CONNECTIONS T/C, mV, DIGITAL INPUT (DI) AND HIGH LEVEL ANALOG INPUT (HLAI)

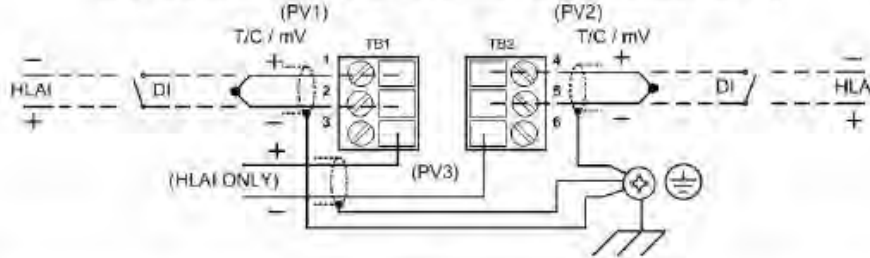

STUW701 - POSSIBLE CONNECTIONS T/C, mV, DIGITAL INPUT (DI), HIGH LEVEL ANALOG INPUT (HLAI) AND DIGITAL OUTPUT (DO)

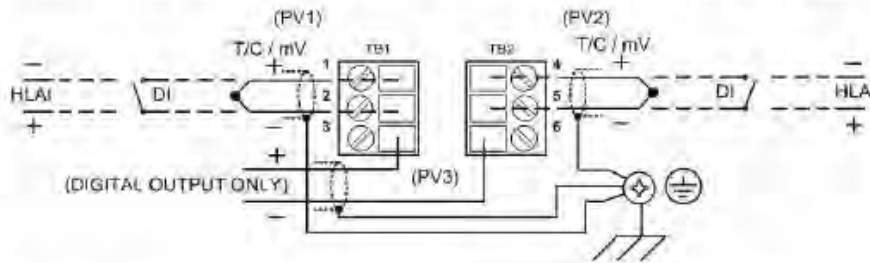

HIGH LEVEL ANALOG INPUT NON-INCENDIVE
 FIELD WIRING & DIGITAL OUTPUT NON-
 INCENDIVE FIELD CIRCUIT PARAMETERS

$U_i (V_{max}) = 30 \text{ V}$
 $I_j (I_{max}) = 125 \text{ mA}$
 $P_i = 1.0 \text{ W}$
 $C_i = 6.8 \text{ nF}$
 $L_i = 0.1 \text{ }\mu\text{H}$

DIGITAL INPUT AND T/C
 NON-INCENDIVE FIELD
 WIRING PARAMETERS

$C_a = 2.7 \text{ }\mu\text{F} \geq C_{Cable}$
 $L_a = 100 \text{ mH} \geq L_{Cable}$

NOTES:

1. Shielded HLAi, DI, DO, thermocouple, mV, or switch input cable is required for EMC conformity and is recommended for all installations. The shield shall be grounded at the transmitter end only. If the shield is grounded at the switch, remote HLAi transmitter location, or remote DO supply the shield shall not be connected at the Wireless transmitter end.

Honeywell

A/A4

50026071

SCALE NONE

REV F

DATE 26 March 2012

SH. 5 of 11

**XYR 6000, MODEL CETW6000M-W WIRELESS CORROSION TRANSMITTER
 AND CETW6000M-D SmartCET CORROSION DATA LOGGER**

HAZARDOUS (CLASSIFIED) LOCATION
 CLASS I, DIV 2, GROUPS A,B,C,D; CLASS II, GROUPS F&G, CLASS III, DIV 2, T4;
 CLASS I, ZONE 2, Ex / AEx nA GROUP IIC, T4; AMBIENT LIMITS: $-30 \leq T_a \leq 85^\circ\text{C}$
 ($\leq 80^\circ\text{C}$ WITH OPTION DC)

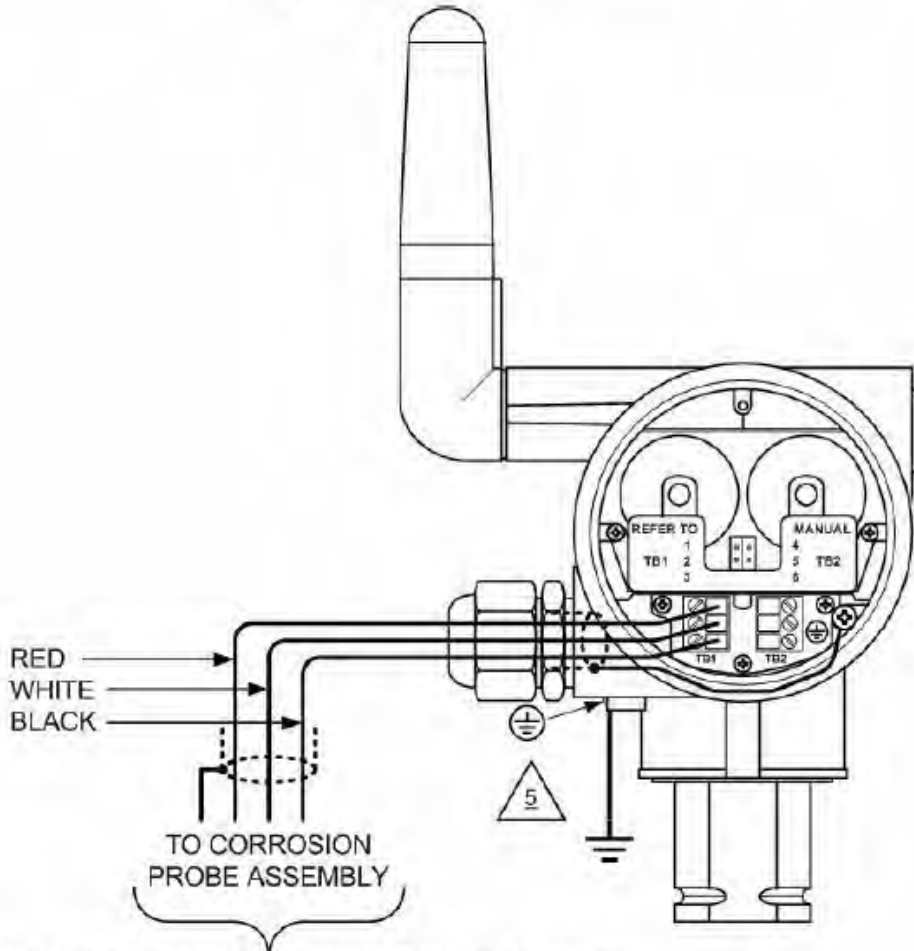

PROBE AND PROCESS ELECTRODES MUST BE PASSIVE
 ELEMENTS ONLY. PROBE AND CABLE PARAMETERS
 MUST NOT EXCEED $100 \mu\text{F} \geq C_{\text{PROBE}} + C_{\text{CABLE}}$ AND
 $100 \text{ mH} \geq L_{\text{PROBE}} + L_{\text{CABLE}}$

NOTE: Probes used with the Corrosion Transmitter must be acceptable to the authority having jurisdiction with respect to pressure and temperature rating.

Honeywell	A/A4	50026071		
	SCALE NONE	REV F	DATE 26 March 2012	SH. 6 of 11

6. Certification Installation Requirements
 Certification Drawings

The following models may be supplied with internal battery power, or externally supplied 24Vdc only when connected per the following system diagram.

NOTE: XYR 6000 ambient limits with 24V Power Supply are -40°C to +80°C.

Model	Description	
STGW944	Series 900 Wireless Transmitter, Dual Head Gage Pressure (GP)	0-500 psi / 0-35 bar
STGW974		0-3000 psi / 0-210 bar
STDW924	Series 900 Wireless Transmitter, Differential Pressure (DP)	0-400" H ₂ O / 0-1000 mbar
STDW930		0-100 psi / 0-7 bar
STDW974		0-3000 psi / 0-210 bar
STGW94L		0-500 psi / 0-35 bar
STGW97L	Series 900 Wireless Transmitter, In-Line Gage & Absolute Pressure	0-3000 psi / 0-210 bar
STGW98L		0-6000 psi / 0-415 bar
STGW99L		0-10,000 psig / 0-690 bar
STAW94L		0-500 psi / 0-35 barA
STFW924	Flanged Series 900 Wireless Pressure Transmitter	0- 400" H ₂ O/ 0- 1000 mbar Compound Characterized
STFW932		0- 100 psi/ 0- 7 bar Compound Characterized
STRW93D	Series 900 Wireless Transmitter, Dual Pressure & Gage Pressure Remote Seals	0- 2700" H ₂ O/ 0- 7 bar Compound Characterized
STRW94G		0- 500 psi/ 0- 35 bar
STFW92F	In-Line Flanged Series 900 Wireless Transmitter	0- 400" H ₂ O/ 0- 1000 mbar
STFW93F		0- 100 psi/ 0- 7 bar
STDW120	Series 100 Wireless Transmitter, Differential Pressure (DP)	0- 400" H ₂ O/ 0- 1000 mbar
STDW125		0- 600" H ₂ O/ 0- 1500 mbar
STDW130		0- 100 psi/ 0- 7 bar
STDW170		0- 3000 psi/ 0-210 bar
STGW14L	Series 100 Wireless Transmitter, In-Line Gage Pressure	0- 500 psi/ 0- 35 bar
STGW17L		0- 3000 psi/ 0- 210 bar
STGW18L		0- 6000 psi/ 0- 415 bar
STGW19L		0- 10000 psi/ 0- 690 bar
STAW14L	Series 100 Wireless Transmitter, In-Line Absolute Pressure	0- 500 psia/ 0- 35 barA
STAW140	Series 100 Wireless Transmitter, Single Head Absolute Pressure	0- 500 psia/ 0- 35 barA
STFW128	Flanged Series 100 Wireless Pressure Transmitter	0- 400" H ₂ O/ 0- 1000 mbar Compound Characterized
STFW132		0- 100 psi/ 0- 7 bar Compound Characterized
STFW12F		0- 400" H ₂ O/ 0- 1000 mbar
STFW13F		0- 100 psi/ 0- 7 bar
STFW14F		0- 600" H ₂ O/ 0- 1500 mbar
STRW12D	Series 100 Wireless Transmitter, Dual Pressure, Gage Pressure and Absolute Remote Seals	0- 400" H ₂ O/ 0- 1000 mbar Compound Characterized
STRW13D		0- 100 psi/ 0- 7 bar
STRW14A		0- 500 psia/ 0- 35 barA
STRW14G		0- 500 psi/ 0- 35 bar
STRW17G		0- 100 psi/ 0- 7 bar
STTW400	Wireless Temperature Transmitter	Transmitter Only with Remote Sensors: 3 T/C's, or 2 RTD's

Honeywell

A/A4

50026071

SCALE NONE

REV F

DATE 26 March 2012

SH. 7 of 11

Model	Description	
STTW401	Wireless Temperature and Digital Input Transmitter	Transmitter Only with Remote Sensors: 1 T/C AND 2 Digital Inputs
STXW500	Wireless Digital Input Transmitter	Three DI (Switch) Inputs
STUW700	Wireless Universal I/O Interface	Three Inputs: 4-20 mA Analog, T/C's, or DI (Switch)
STUW701	Wireless Universal I/O Interface	Two Inputs: 4-20 mA Analog, T/C or DI and One Digital Output (Solid State)
STTW820 STTW830 STTW840	Wireless Temperature Transmitter	Transmitter Integrally Mounted to Thermowell or Probe Assembly
STIW600	Wireless High Level Input Interface	4-20 mA Analog Input
CETW6000M-W	SmartCET Wireless Transmitter, Corrosion Monitoring	Millivolt Input from Remote Mounted Corrosion Probe
CETW6000M-D	SmartCET Corrosion Data Logger	Millivolt Input from Remote Mounted Corrosion Probe, Data via IrDA Port *

* There is no Antenna for this version

The above listed wireless transmitters may include an Omni-directional or unidirectional high-gain antenna. The high-gain antenna may be installed remote from the XYR 6000 with the cable length not to exceed 20m. The antenna cable shield shall be bonded to earth ground.

NON-INCENDIVE FIELD CIRCUIT PARAMETERS for remote antennas, cables & lightning arrestor:
Ca = 43 μ F, La = 0.1 mH.

Honeywell	A/A4	50026071		
	SCALE NONE	REV F	DATE 26 March 2012	SH. 8 of 11

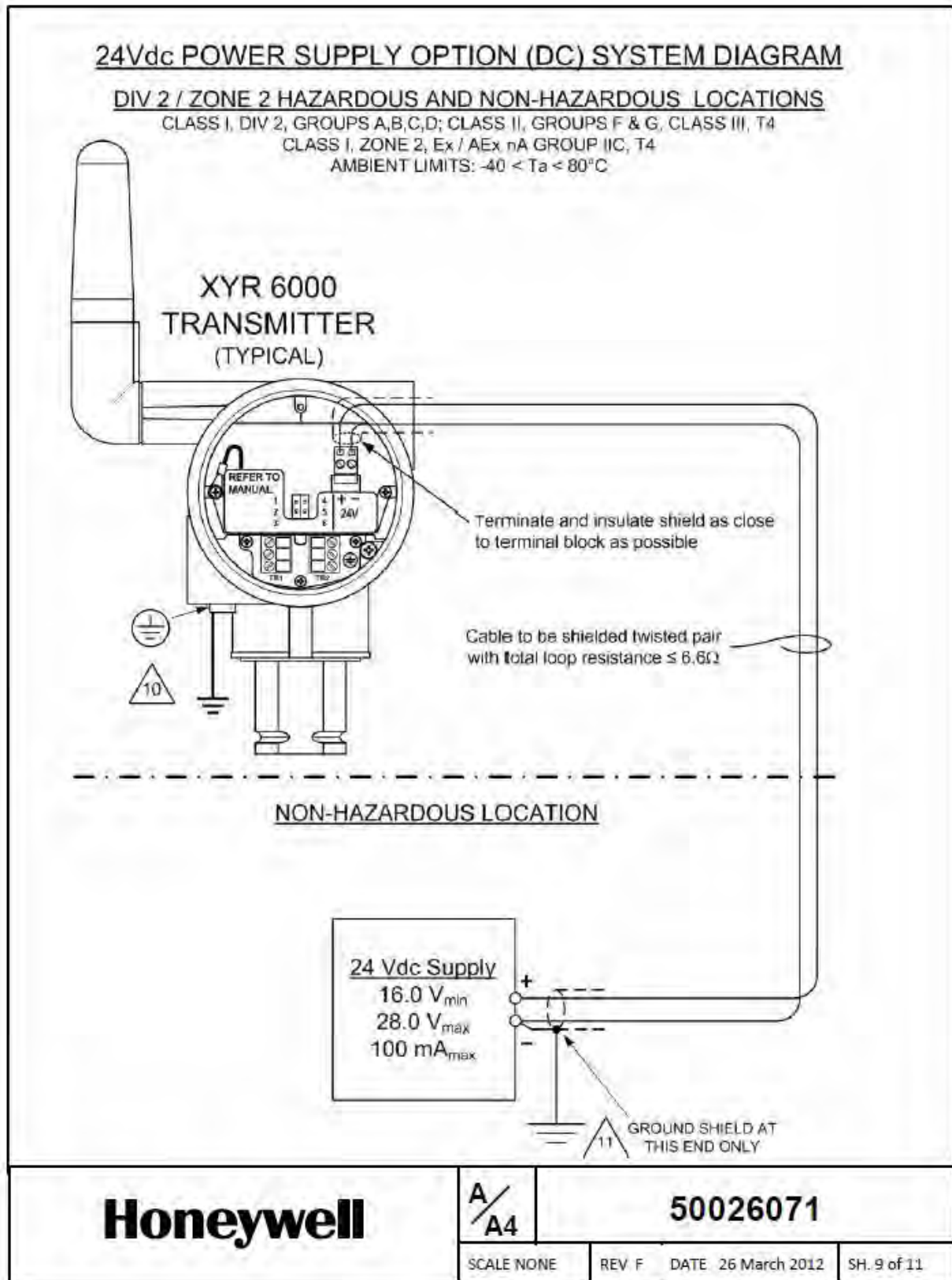

REMOTE ANTENNAS MUST BE PASSIVE ELEMENTS ONLY

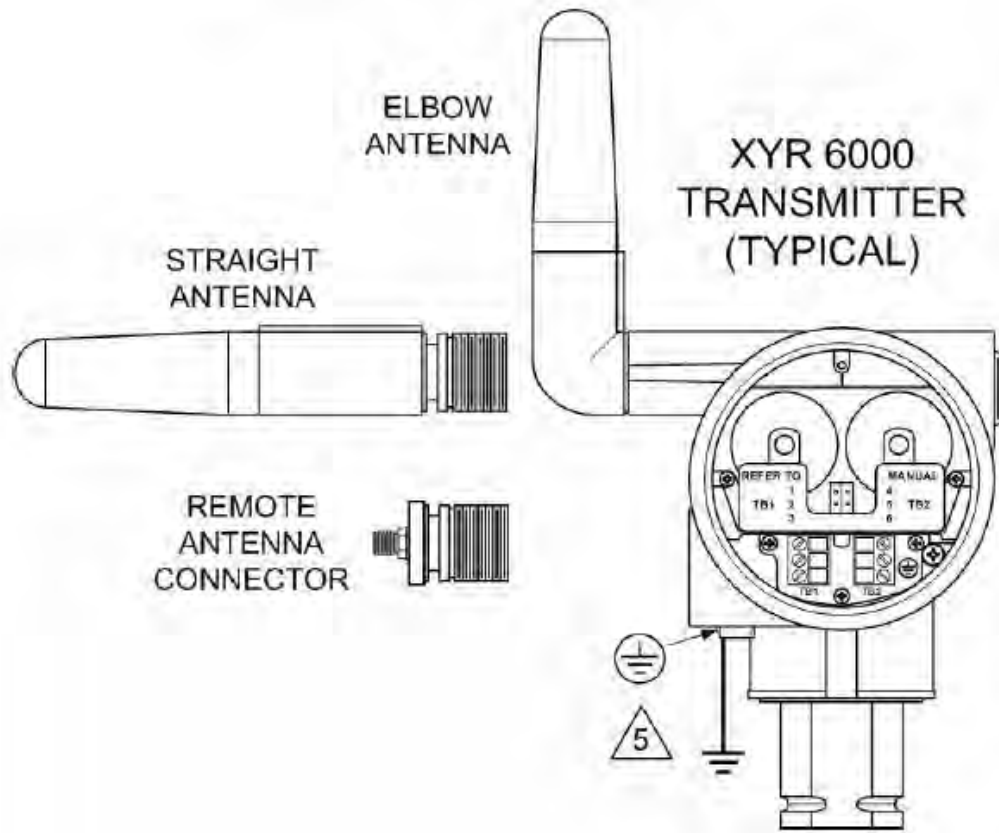

Honeywell

A/A4

50026071

SCALE NONE

REV F

DATE 26 March 2012

SH. 10 of 11

6. Certification Installation Requirements
 Certification Drawings

Non-Incendive Field Wiring parameters for remote antennas, cables & lightning arrestor:
 $C_a \leq 43 \mu F$, $L_a \leq 48 \text{ mH}$.

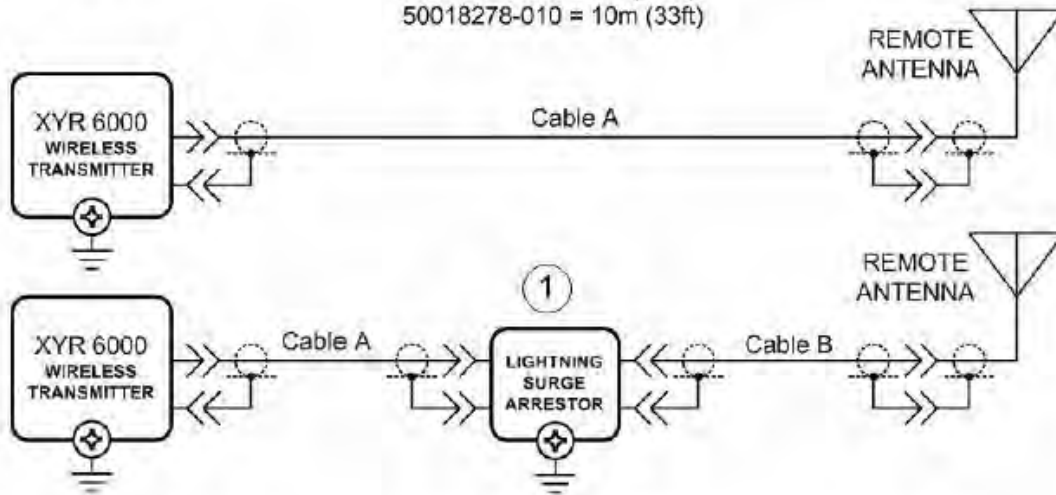
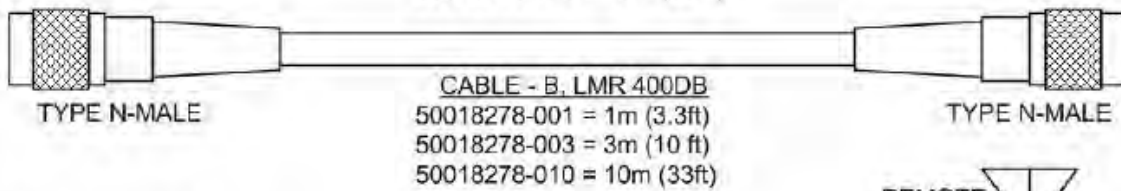
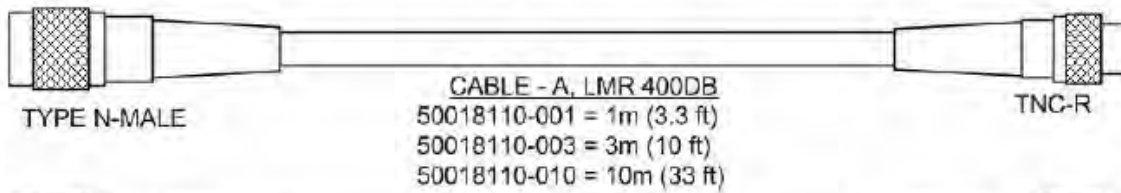

CABLE PARAMETERS		
CABLE A, B LENGTH	CAPACITANCE	INDUCTANCE
1 m	78.4 pF	0.2 μH
3 m	235.2 pF	0.6 μH
10 m	784 pF	2.0 μH

NOTES:

1. Only lightning surge arrestors determined to be simple apparatus may be installed.

Honeywell	A/A4	50026071		
	SCALE NONE	REV F	DATE 26 March 2012	SH. 11 of 11

COPYRIGHT 2010, HONEYWELL INTERNATIONAL INC. NEITHER THIS DOCUMENT NOR THE INFORMATION CONTAINED HEREIN SHALL BE REPRODUCED, USED OR DISCLOSED TO OTHERS WITHOUT THE WRITTEN AUTHORIZATION OF HONEYWELL. USE, DUPLICATION, OR DISCLOSURE OF THIS DOCUMENT IS SUBJECT TO THE RESTRICTIONS SET FORTH IN A WRITTEN AGREEMENT. NOTHING CONTAINED HEREIN SHALL BE CONSTRUED AS CONFERRING BY IMPLICATION, ESTOPPEL, OR OTHERWISE ANY LICENSE TO ANY PATENT, TRADEMARK, COPYRIGHT OR OTHER INTELLECTUAL PROPERTY RIGHT OF HONEYWELL OR ANY THIRD PARTY.

PRE REL							
ISS	REVISION & DATE						APPD
F	26 March 2012 ECO-0069377						VM

XYR 6000 WIRELESS TRANSMITTERS CSA CERTIFIED & FM APPROVED DIVISION 1/ ZONE 0 INSTALLATION CONTROL DRAWING

NOTES:

- Intrinsically safe installation shall be in accordance with the Canadian Electrical Code (CEC), part I, Section 18 for Canada, ANSI/NFPA 70, NEC® Articles 504 and 505 for the USA, and ANSI/ISA RP12.06.01.
 - CSA or FM ENTITY approved apparatus shall be installed in accordance with the manufacturer's Intrinsic Safety Control Drawing or shall be Simple Apparatus. Simple Apparatus are devices that will neither generate nor store more than 1.2V, 0.1A, 25mW, or 20µJ, such as switches, thermocouples, and RTDs.
 - The Intrinsic Safety ENTITY concept allows the interconnection of two ENTITY Approved Intrinsically safe devices with ENTITY parameters not specifically examined in combination as a system when:
 $U_o \text{ or } V_o \text{ (or } V_t \text{ in the USA)} \leq U_i \text{ or } V_{max}$, $I_o \text{ or } I_{sc} \text{ (or } I_t \text{ in the USA)} \leq I_i \text{ or } I_{max}$, $C_a \text{ or } C_o \geq C_i + C_{cable}$, $L_a \text{ or } L_o \geq L_i + L_{cable}$, $P_o \leq P_i$. Where two separate barrier channels are required, one dual-channel or two single-channel barriers may be used, where in either case, both channels have been Certified for use together with combined entity parameters that meet the above equations.
 - System Parameters:
 XYR 6000 and Field Transmitter $V_{max} \geq V_o \text{ or } U_o$, $I_{max} \geq I_o \text{ or } I_i$;
 XYR 6000 $C_i + \text{Field Transmitter } C_i + C_{cable} \leq \text{Control Apparatus } C_a$,
 XYR 6000 $L_i + \text{Field Transmitter } L_i + L_{cable} \leq \text{Control Apparatus } L_a$.
 - When the electrical parameters of the cable are unknown, the following values may be used: Capacitance – 197pF/m (60 pF/ft), Inductance – 0.66µH/m (0.020 µH/ft).
 - For Class II and Class III installations where rigid metal conduit is not used, seal cable entries against dust and fibers using a NRTL listed cable gland fitting.
 - Control equipment that is connected to Associated apparatus must not use or generate more than 250 V.
 - Associated apparatus must be CSA Certified under the ENTITY Concept in Canada and FM ENTITY listed in the USA. Associated apparatus may be installed in a Class I, Division 2 Hazardous (Classified) location if so approved.
 - Non-Galvanically isolated apparatus (grounded Zener Barriers) must be connected to a suitable ground electrode per NFPA 70, Article 504 and 505 in the USA and CEC Part I, Section 10 in Canada. The resistance of the ground path must be less than 1.0 ohm.
10. Transmitters shall have the enclosure bonded to ground in accordance with CEC part I, Section 18-074, Bonding in hazardous locations, and Rule 10-814
11. Shielded two-wire cable is required for EMC conformity and is recommended for all installations. The 4-20 mA loop shield shall be grounded at the supply (barrier) end to the barrier ground bus only when grounded Zener barriers are used. The 4-20 mA loop shield shall be grounded at the transmitter end only when galvanically isolated barriers are used.

MASTER FILE TYPE: MS WORD

CERTIFICATION DOCUMENT ENGINEERING CHANGE ORDERS (ECOs) MUST BE AUTHORIZED BY APPROVALS ENGINEERING	DRAWN	RJP	1/3/08	Honeywell			
	CHECKED	FMK	1/3/08	CSA & FM Control Drawing XYR 6000 Wireless Transmitters Division 1 / Zone 0			
	DEV ENG	NOTE 15		A A4			
	MFG ENG						
	QA ENG			50021730			
	TOLERANCE UNLESS NOTED			SCALE USED ON SH.1 OF 12			
ANGULAR DIMENSION							

6. Certification Installation Requirements
 Certification Drawings

- 12. Divisions 1 & 2, and Zone 0: WARNING: EXPLOSION HAZARD – SUBSTITUTION OF COMPONENTS MAY IMPAIR SUITABILITY FOR USE IN HAZARDOUS LOCATIONS.
- 13. Division 2: WARNING: EXPLOSION HAZARD – DO NOT DISCONNECT EQUIPMENT UNLESS POWER HAS BEEN SWITCHED OFF OR THE AREA IS KNOWN TO BE NON-HAZARDOUS.
- 14. NO REVISION OF THIS CONTROL DRAWING IS PERMITTED WITHOUT AUTHORIZATION FROM CSA AND FM Approvals.
- 15. For release approvals see ECO # 0036573.

XYR 6000 STIW600	Field Transmitter	Associated Apparatus
U_i or $V_{max} = 30$ V	$U_i, V_{max},$ or $V_t \geq$	U_o, V_{oc} or $V_t \leq 30$ V
I_i or $I_{max} = 125$ mA	$I_i, I_{max},$ or $I_t \geq$	I_o, I_{sc} or $I_t \leq 125$ mA
P_i or $P_{max} = 1.0$ W	$P_{max} \geq P_o$	$P_o \leq \frac{(V_{oc} \text{ or } V_t \cdot I_{sc} \text{ or } I_t)}{4} \leq 1.0$ W
$C_i = 6.8$ nF	$C_i \leq$ Associated Apparatus C_a – C_{cable} – C_i of other transmitter connected to two-channel barrier.	C_a (or C_o) > 6.8 nF
$L_i = 0$	$L_i \leq$ Associated Apparatus L_a – L_{cable} – L_i of other transmitter connected to two-channel barrier.	L_a (or L_o) > 0 mH

Honeywell	A/A4	50021730		
	SCALE NONE	REV F	DATE 26 March 2012	SH. 2 of 12

**CSA CERTIFIED & FM APPROVED INTRINSICALLY SAFE
 INSTALLATION CONTROL DRAWING – TWO-WIRE CONFIGURATION
XYR 6000, STIW600. 0–20 mA / 4–20 mA HIGH LEVEL INPUT INTERFACE**

NON-HAZARDOUS LOCATION

**ASSOCIATED APPARATUS
 IS FIELD WIRING
 PARAMETERS**

U_o (V_{oc} or V_t) \leq 30 V
 I_o (I_{sc} or I_t) \leq 125 mA
 $P_o \leq$ 1.0 W
 $C_a \geq C_{cable} + C_{Field\ Transmitter} + 6.8\ nF$
 $L_a \geq L_{cable} + L_{Field\ Transmitter} + 0.1\ \mu H$

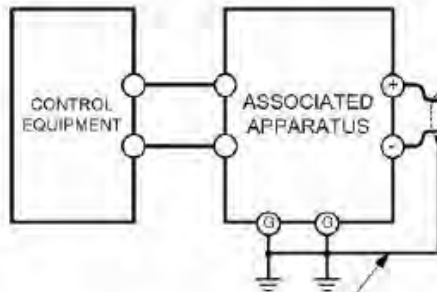

HAZARDOUS (CLASSIFIED) LOCATION

XYR 6000 WIRELESS TRANSMITTER
 CLASS I, DIV 1, GROUPS A,B,C,D;
 CLASS II, GROUPS E,F & G, CLASS III, DIV 1, T4;
 CLASS I, ZONE 0, EX / AEx ia GROUP IIC, T4
 AMBIENT LIMITS: $-40 \leq T_a \leq 85^\circ C$
 ($\leq 80^\circ C$ WITH OPTION DC)

ENTITY PARAMETERS

U_i (V_{max}) = 30 V
 I_i (I_{max}) = 125 mA
 $P_i = 1.0\ W$
 $C_i = 6.8\ nF$
 $L_i = 0.1\ \mu H$

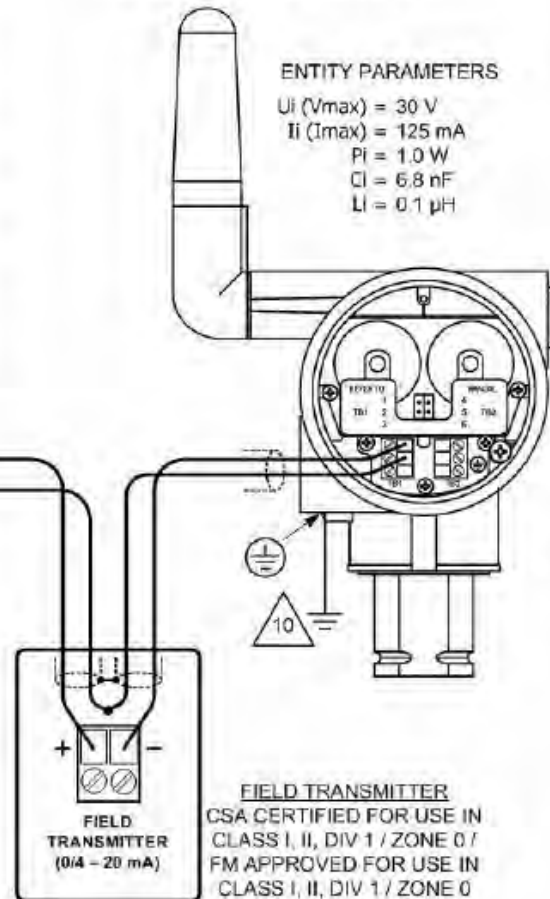

FIELD TRANSMITTER
 CSA CERTIFIED FOR USE IN
 CLASS I, II, DIV 1 / ZONE 0 /
 FM APPROVED FOR USE IN
 CLASS I, II, DIV 1 / ZONE 0

Honeywell

A/A4

50021730

SCALE NONE REV F DATE 26 March 2012 SH. 3 of 12

**WIRELESS TEMPERATURE AND DIGITAL INPUT (DI) TRANSMITTERS
 STTW400, STTW401, STXW500, STT820, STTW830 & STTW840**

HAZARDOUS (CLASSIFIED) LOCATION

CLASS I, DIV 1, GROUPS A, B, C, D; CLASS II DIV 1, GROUPS E, F & G, CLASS III, DIV 1, T4;

CLASS I, ZONE 0 Ex/AEx ia GROUP IIC, T4;

AMBIENT LIMITS: $-40 < T_a < 85^{\circ}\text{C}$ ($< 80^{\circ}\text{C}$ WITH OPTION DC)

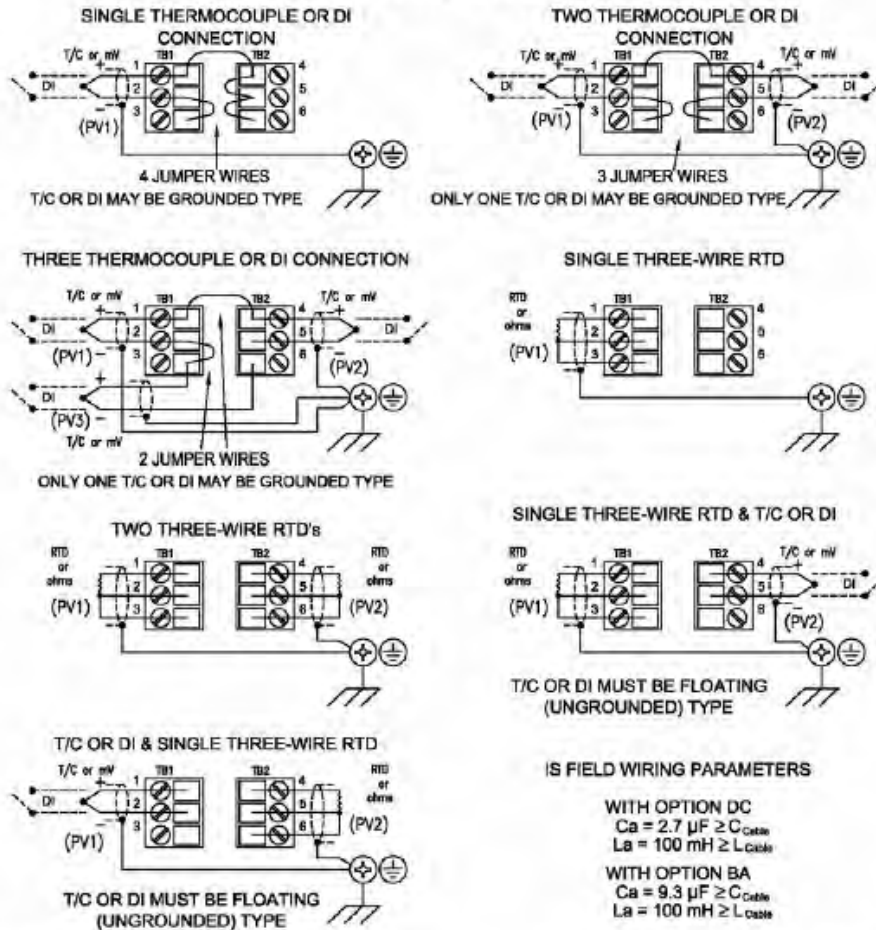

NOTES:

1. Shielded thermocouple/mV or RTD/Ohms cable is required for EMC conformity and is recommended for all remote sensor installations. The shield shall be grounded at the transmitter end only.
2. When remote mounted probe sensors are used and the shield is grounded at the probe, the shield shall not be connected at the transmitter end.
3. Duplex (redundant) sensors that are bonded to the probe are not permitted. All thermocouple/mV inputs and RTD/Ohms inputs must be insulated from ground (the probe) and from each other as noted above.
4. Jumper wires the same gauge and stranding as the thermocouple wires are required for single and dual thermocouple input combinations.
5. Digital input switches, DI, must be dry contact type, simple apparatus and properly segregated from all other sources of power.

Honeywell	A/A4	50021730		
	SCALE NONE	REV F	DATE 26 March 2012	SH. 4 of 12

**WIRELESS TEMPERATURE AND DIGITAL INPUT (DI) TRANSMITTERS
STTW400, STTW401, STXW500, STTW820, STTW830 & STTW840**

HAZARDOUS (CLASSIFIED) LOCATION

CLASS I, DIV 1, GROUPS A, B, C, D; CLASS II DIV 1, GROUPS E, F & G, CLASS III, DIV 1, T4;
CLASS I, ZONE 0 Ex/AEx ia GROUP IIC, T4;
AMBIENT LIMITS: $-40 < T_a < 85^{\circ}\text{C}$ ($< 80^{\circ}\text{C}$ WITH OPTION DC)

SINGLE TWO-WIRE RTD

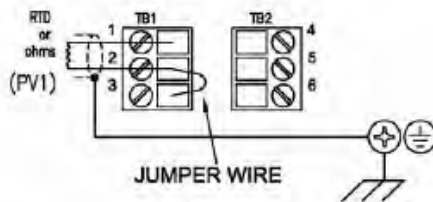

TWO TWO-WIRE RTD

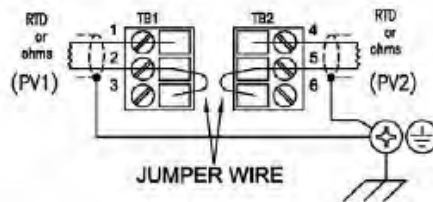

T/C OR DI & SINGLE TWO-WIRE RTD

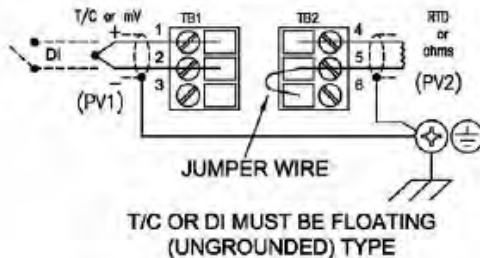

SINGLE TWO-WIRE RTD & T/C OR DI

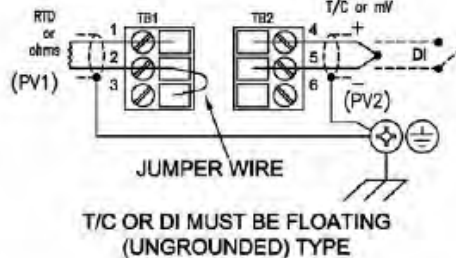

IS FIELD WIRING PARAMETERS

WITH OPTION DC
 $C_a = 2.7 \mu\text{F} \geq C_{\text{Cable}}$
 $L_a = 100 \text{ mH} \geq L_{\text{Cable}}$
 WITH OPTION BA
 $C_a = 9.3 \mu\text{F} \geq C_{\text{Cable}}$
 $L_a = 100 \text{ mH} \geq L_{\text{Cable}}$

NOTES:

1. Shielded thermocouple/mV or RTD/Ohms cable is required for EMC conformity and is recommended for all remote sensor installations. The shield shall be grounded at the transmitter end only.
2. When remote mounted probe sensors are used and the shield is grounded at the probe, the shield shall not be connected at the transmitter end.
3. Duplex (redundant) sensors that are bonded to the probe are not permitted. All thermocouple/mV inputs and RTD/Ohms inputs must be insulated from ground (the probe) and from each other as noted above.
4. Jumper wires the same gauge and stranding as the thermocouple wires are required for single and dual thermocouple input combinations.
5. Digital input switches, DI, must be dry contact type, simple apparatus and properly segregated from all other sources of power.

Honeywell

A/A4

50021730

SCALE NONE

REV F

DATE 26 March 2012

SH. 5 of 12

WIRELESS UNIVERSAL I/O - STUW700 & STUW701

HAZARDOUS (CLASSIFIED) LOCATION
 CLASS I, DIV 1, GROUPS A,B,C,D; CLASS II, DIV 1, GROUPS E,F & G, CLASS III, DIV 1, T4;
 CLASS I, ZONE 0, Ex / AEx ia GROUP IIC, T4; AMBIENT LIMITS: $-40 \leq T_a \leq 85^\circ\text{C}$ ($\leq 80^\circ\text{C}$ WITH OPTION DC)

STUW700 - POSSIBLE CONNECTIONS T/C, mV, DIGITAL INPUT (DI) AND HIGH LEVEL ANALOG INPUT (HLAI)

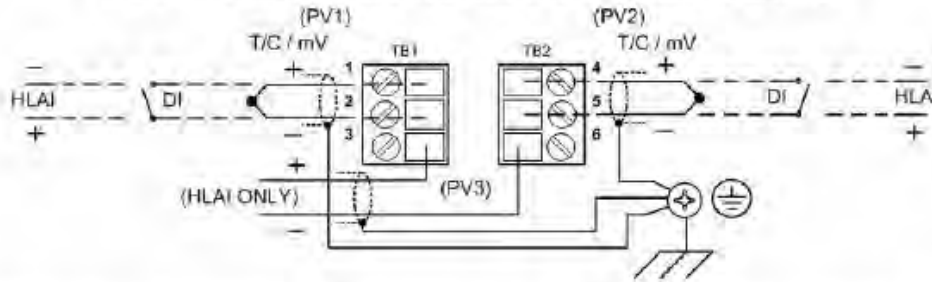

STUW701 - POSSIBLE CONNECTIONS T/C, mV, DIGITAL INPUT (DI), HIGH LEVEL ANALOG INPUT (HLAI) AND DIGITAL OUTPUT (DO)

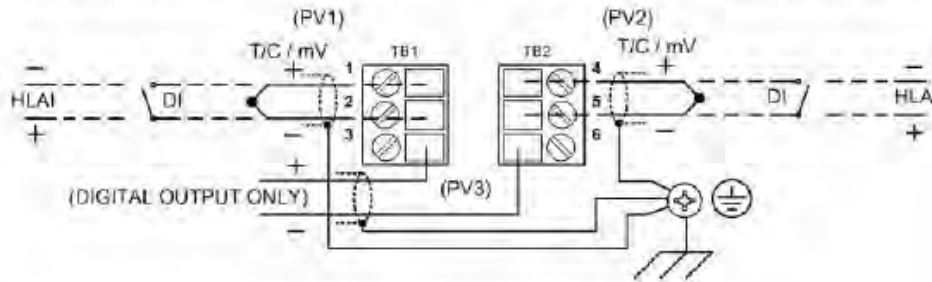

HIGH LEVEL ANALOG INPUT &
 DIGITAL OUTPUT ENTITY
 PARAMETERS

$U_i (V_{max}) = 30 \text{ V}$
 $I_i (I_{max}) = 125 \text{ mA}$
 $P_i = 1.0 \text{ W}$
 $C_i = 6.8 \text{ nF}$
 $L_i = 0.1 \mu\text{H}$

DIGITAL INPUT AND T/C
 FIELD WIRING
 PARAMETERS

$C_a = 2.7 \mu\text{F} \geq C_{Cable}$
 $L_a = 100 \text{ mH} \geq L_{Cable}$

NOTES:

1. Shielded HLAJ, DI, DO, thermocouple, mV, or switch input cable is required for EMC conformity and is recommended for all installations. The shield shall be grounded at the transmitter end only. If the shield is grounded at the switch, remote HLAJ transmitter location, or remote DO supply the shield shall not be connected at the Wireless transmitter end.

Honeywell

A/A4

50021730

SCALE NONE

REV F

DATE 26 March 2012

SH. 6 of 12

**XYR 6000, MODEL CETW6000M-W WIRELESS CORROSION TRANSMITTER
 AND CETW6000M-D SmartCET CORROSION DATA LOGGER**

HAZARDOUS (CLASSIFIED) LOCATION
 CLASS I, DIV 1, GROUPS A,B,C,D; CLASS II, GROUPS E,F&G, CLASS III, DIV 1, T4;
 CLASS I, ZONE 0, Ex / AEx ia GROUP IIC, T4; AMBIENT LIMITS: $-30 \leq T_a \leq 85^\circ\text{C}$
 ($\leq 80^\circ\text{C}$ WITH OPTION DC)

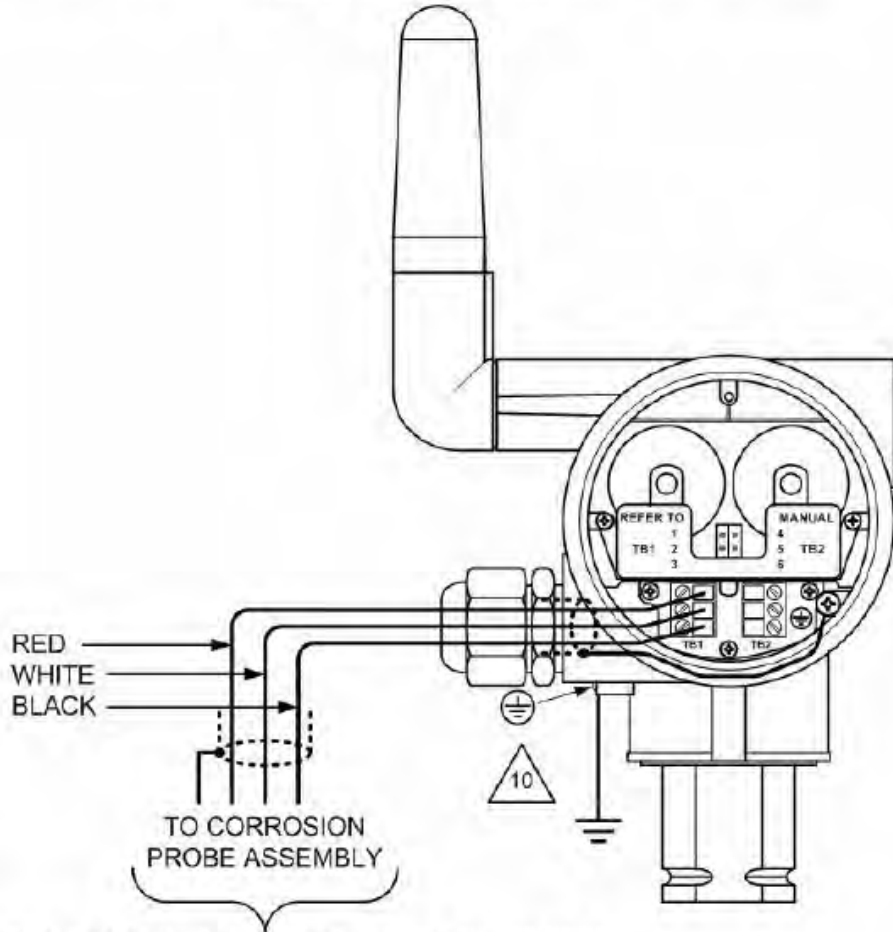

PROBE AND PROCESS ELECTRODES MUST BE PASSIVE
 ELEMENTS ONLY. PROBE AND CABLE PARAMETERS
 MUST NOT EXCEED $43 \mu\text{F} \geq C_{\text{PROBE}} + C_{\text{CABLE}}$ AND
 $100 \text{ mH} \geq L_{\text{PROBE}} + L_{\text{CABLE}}$

NOTE: Probes used with the Corrosion Transmitter must be acceptable to the authority having jurisdiction with respect to pressure and temperature rating.

Honeywell	A/A4	50021730		
	SCALE NONE	REV F	DATE 26 March 2012	SH. 7 of 12

6. Certification Installation Requirements
 Certification Drawings

The following models may be supplied with internal battery power, or externally supplied 24Vdc only when connected to the MTL Associated Apparatus listed on the following system diagram.

NOTE: XYR 6000 ambient limits with 24V Power Supply are -40°C to +80°C.

Model	Description	
STGW944	Series 900 Wireless Transmitter, Dual Head Gage Pressure (GP)	0-500 psi / 0-35 bar
STGW974		0-3000 psi / 0-210 bar
STDW924	Series 900 Wireless Transmitter, Differential Pressure (DP)	0-400" H ₂ O / 0-1000 mbar
STDW930		0-100 psi / 0-7 bar
STDW974		0-3000 psi / 0-210 bar
STGW94L		0-500 psi / 0-35 bar
STGW97L	Series 900 Wireless Transmitter, In-Line Gage & Absolute Pressure	0-3000 psi / 0-210 bar
STGW98L		0-6000 psi / 0-415 bar
STGW99L		0-10,000 psig / 0-690 bar
STAW94L		0-500 psi / 0-35 barA
STFW924	Flanged Series 900 Wireless Pressure Transmitter	0- 400" H ₂ O/ 0- 1000 mbar Compound Characterized
STFW932		0- 100 psi/ 0- 7 bar Compound Characterized
STRW93D	Series 900 Wireless Transmitter, Dual Pressure & Gage Pressure Remote Seals	0- 2700" H ₂ O/ 0- 7 bar Compound Characterized
STRW94G		0- 500 psi/ 0- 35 bar
STFW92F	In-Line Flanged Series 900 Wireless Transmitter	0- 400" H ₂ O/ 0- 1000 mbar
STFW93F		0- 100 psi/ 0- 7 bar
STDW120	Series 100 Wireless Transmitter, Differential Pressure (DP)	0- 400" H ₂ O/ 0- 1000 mbar
STDW125		0- 600" H ₂ O/ 0- 1500 mbar
STDW130		0- 100 psi/ 0- 7 bar
STDW170		0- 3000 psi/ 0-210 bar
STGW14L		0- 500 psi/ 0- 35 bar
STGW17L	Series 100 Wireless Transmitter, In-Line Gage Pressure	0- 3000 psi/ 0- 210 bar
STGW18L		0- 6000 psi/ 0- 415 bar
STGW19L		0- 10000 psi/ 0- 690 bar
STAW14L	Series 100 Wireless Transmitter, In-Line Absolute Pressure	0- 500 psia/ 0- 35 barA
STAW140	Series 100 Wireless Transmitter, Single Head Absolute Pressure	0- 500 psia/ 0- 35 barA
STFW128	Flanged Series 100 Wireless Pressure Transmitter	0- 400" H ₂ O/ 0- 1000 mbar Compound Characterized
STFW132		0- 100 psi/ 0- 7 bar Compound Characterized
STFW12F		0- 400" H ₂ O/ 0- 1000 mbar
STFW13F		0- 100 psi/ 0- 7 bar
STFW14F		0- 600" H ₂ O/ 0- 1500 mbar
STRW12D		0- 400" H ₂ O/ 0- 1000 mbar Compound Characterized
STRW13D	Series 100 Wireless Transmitter, Dual Pressure, Gage Pressure and Absolute Remote Seals	0- 100 psi/ 0- 7 bar
STRW14A		0- 500 psia/ 0- 35 barA
STRW14G		0- 500 psi/ 0- 35 bar
STRW17G		0- 100 psi/ 0- 7 bar
STTW400	Wireless Temperature Transmitter	Transmitter Only with Remote Sensors:

Honeywell

A/A4

50021730

SCALE NONE

REV F

DATE 26 March 2012

SH. 8 of 12

Model	Description	
		3 T/C's, or 2 RTD's
STTW401	Wireless Temperature and Digital Input Transmitter	Transmitter Only with Remote Sensors: 1 T/C AND 2 Digital Inputs
STXW500	Wireless Digital Input Transmitter	Three DI (Switch) Inputs
STUW700	Wireless Universal I/O Interface	Three Inputs: 4-20 mA Analog, T/C's, or DI (Switch)
STUW701	Wireless Universal I/O Interface	Two Inputs: 4-20 mA Analog, T/C or DI and One Digital Output (Solid State)
STTW820 STTW830 STTW840	Wireless Temperature Transmitter	Transmitter Integrally Mounted to Thermowell or Probe Assembly
STIW600	Wireless High Level Input Interface	4-20 mA Analog Input
CETW6000M-W	SmartCET Wireless Transmitter, Corrosion Monitoring	Millivolt Input from Remote Mounted Corrosion Probe
CETW6000M-D	SmartCET Corrosion Data Logger	Millivolt Input from Remote Mounted Corrosion Probe, Data via IrDA Port *

* There is no Antenna for this version

The above listed wireless transmitters may include an Omni-directional or unidirectional high-gain antenna. The high-gain antenna may be installed remote from the XYR 6000 with the cable length not to exceed 20m. The antenna cable shield shall be bonded to earth ground.

IS Entity parameters for remote antennas, cables & lightning arrestor:
Ca = 43 µF, La = 0.1 mH.

Honeywell	A/A4	50021730		
	SCALE NONE	REV F	DATE 26 March 2012	SH. 9 of 12

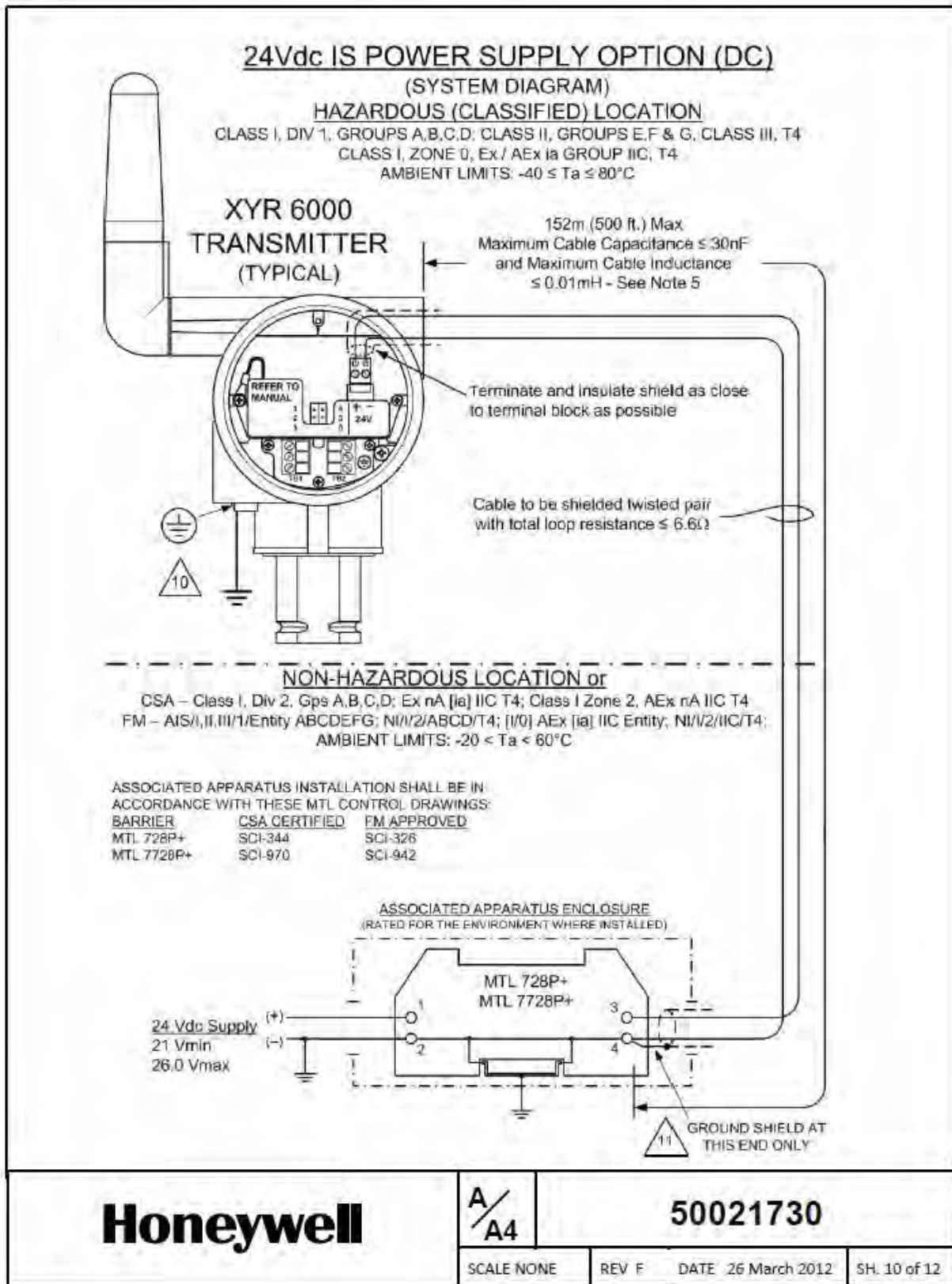

REMOTE ANTENNAS MUST BE
 PASSIVE ELEMENTS ONLY

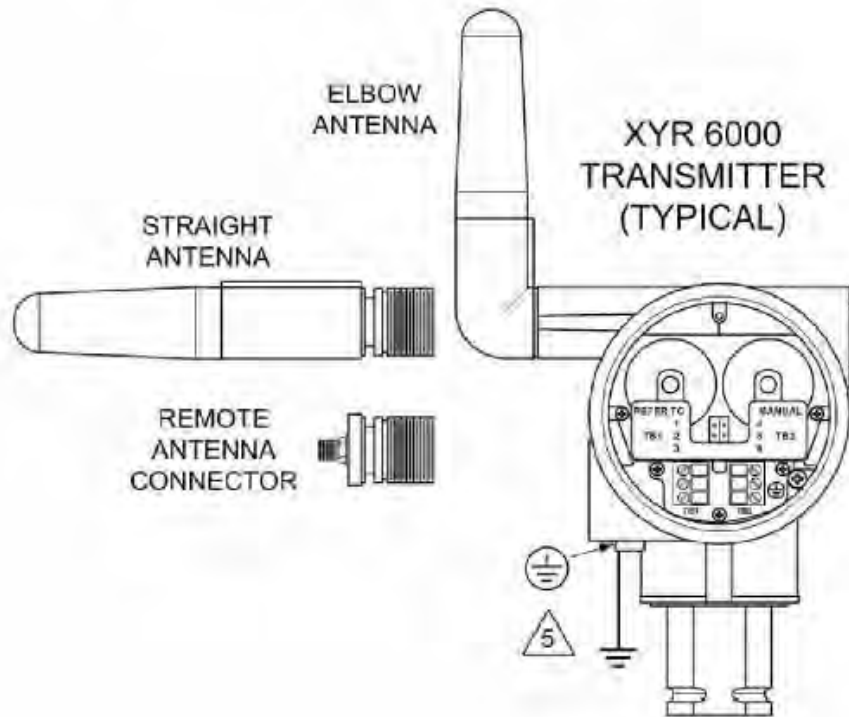

Honeywell

A/A4

50021730

SCALE NONE

REV F

DATE 26 March 2012

SH. 11 of 12

6. Certification Installation Requirements
 Certification Drawings

IS Entity parameters for remote antennas, cables & lightning arrester:
 $C_a \leq 43 \mu\text{F}$, $L_a \leq 0.1 \text{ mH}$.

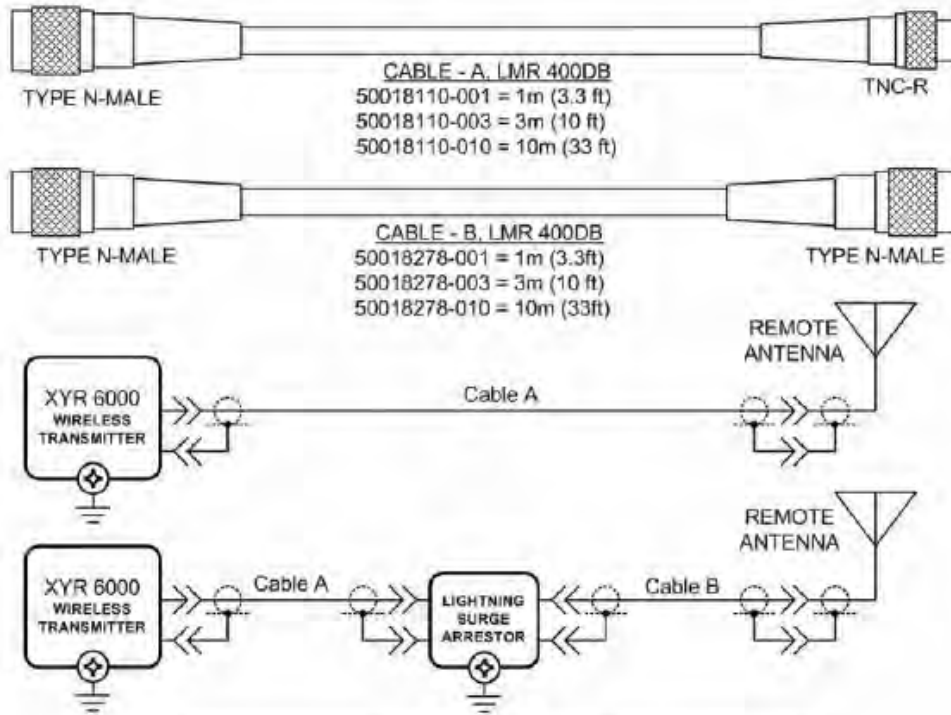

CABLE PARAMETERS		
CABLE A, B LENGTH	CAPACITANCE	INDUCTANCE
1 m	78.4 pF	0.2 μH
3 m	235.2 pF	0.6 μH
10 m	784 pF	2.0 μH

NOTES:

1. Only lightning surge arrestors determined to be simple apparatus may be installed.

Honeywell

A/A4

50021730

SCALE NONE

REV F

DATE 26 March 2012

SH. 12 of 12

ATEX Control Drawings

COPYRIGHT 2012, HONEYWELL INTERNATIONAL INC. NEITHER THIS DOCUMENT NOR THE INFORMATION CONTAINED HEREIN SHALL BE REPRODUCED, USED OR DISCLOSED TO OTHERS WITHOUT THE WRITTEN AUTHORIZATION OF HONEYWELL. USE, DUPLICATION, OR DISCLOSURE OF THIS DOCUMENT IS SUBJECT TO THE RESTRICTIONS SET FORTH IN A WRITTEN AGREEMENT. NOTHING CONTAINED HEREIN SHALL BE CONSTRUED AS CONFERRING BY IMPLICATION, ESTOPPEL, OR OTHERWISE ANY LICENSE TO ANY PATENT, TRADEMARK, COPYRIGHT OR OTHER INTELLECTUAL PROPERTY RIGHT OF HONEYWELL OR ANY THIRD PARTY.	ISS	REVISION & DATE	APPD
	F	26 March 2012 ECO-0069377	VM

ATEX INTRINSICALLY SAFE (ia) AND NON-SPARKING (n) INSTALLATION CONTROL DRAWING XYR 6000 WIRELESS TRANSMITTERS

NOTES:

1. Electrical apparatus and circuits can be used in zone 0 if they are in accordance with IEC 60079-11 (category "ia" – intrinsic safety), the applicable parts of IEC 60079-0 and with the requirements of IEC 60079-14, 12.3 (see also 5.2.4).
2. Electrical apparatus and circuits can be used in zone 2 if they are in accordance with IEC 60079-15, the applicable parts of IEC 60079-0 and with the requirements of IEC 60079-14, 12.2.
3. ATEX certified intrinsically safe apparatus shall be installed in accordance with the manufacturer's Intrinsic Safety Control Drawing or shall be Simple Apparatus. Simple Apparatus are devices that will neither generate nor store more than 1.2V, 0.1A, 25mW, or 20µJ, such as switches, thermocouples, and RTDs. ATEX certified non-sparking apparatus shall be installed per this control drawing.
4. Intrinsic Safety system parameters shall comply with the following:
 $U_o \leq U_i$, $I_o \leq I_i$, $C_o \geq C_i + C_{cable}$, $L_o \geq L_i + L_{cable}$, $P_o \leq P_i$. Where two separate barrier channels are required, one dual-channel or two single-channel barriers may be used, where in either case, both channels have been Certified for use together with combined entity parameters that meet the above equations.
5. System Parameters:
 XYR 6000 and Field Transmitter $U_i \geq U_o$, $I_i \geq I_o$;
 XYR 6000 $C_i + \text{Field Transmitter } C_i + C_{cable} \leq \text{Associated Apparatus } C_o$,
 XYR 6000 $L_i + \text{Field Transmitter } L_i + L_{cable} \leq \text{Associated Apparatus } L_o$.
6. When the electrical parameters of the cable are unknown, the following values may be used: Capacitance – 197pF/m, Inductance – 0.66µH/m.
7. For ATEX IEC 60079-0 Ex II/III installations where rigid metal conduit is not used, seal cable entries against dust and fibers using a certified cable gland fitting.
8. Control equipment that is connected to associated apparatus must not use or generate more than 250 V.
9. Associated apparatus must be ATEX certified. Associated apparatus may be installed in a Zone 2 location if so approved.
- Non-Galvanically isolated apparatus (grounded Zener Barriers) must be connected to a suitable ground electrode per IEC 60079-14, Clause 12.2.4. The resistance of the ground path must be less than 1.0 ohm.
11. Shielded two-wire cable is required for EMC conformity and is recommended for all installations. The 4-20 mA loop shield shall be grounded at the supply (barrier) end to the barrier ground bus only when grounded Zener barriers are used. The 4-20 mA loop shield shall be grounded at the transmitter end only when galvanically isolated barriers are used.

MASTER FILE TYPE: MS WORD

CERTIFICATION DOCUMENT ENGINEERING CHANGE ORDERS (ECOs) MUST BE AUTHORIZED BY APPROVALS ENGINEERING	DRAWN	F.Kent		Honeywell		
	CHECKED			ATEX Control Drawing		
	DEV ENG	NOTE 15		XYR 6000 Wireless Transmitters		
	MFG ENG			Zones 0, 1 & 2		
	QA ENG			A	50033269	
	TOLERANCE UNLESS NOTED			A4		
ANGULAR DIMENSION			SCALE	USED ON	SH.1 OF 12	

6. Certification Installation Requirements
 Certification Drawings

- 12. Zone 0 or Zone 1: WARNING: EXPLOSION HAZARD – SUBSTITUTION OF COMPONENTS MAY IMPAIR SUITABILITY FOR USE IN HAZARDOUS LOCATIONS.
- 13. Zone 2: WARNING: EXPLOSION HAZARD – DO NOT DISCONNECT EQUIPMENT UNLESS POWER HAS BEEN SWITCHED OFF OR THE AREA IS KNOWN TO BE NON-HAZARDOUS.
- 14. NO REVISION OF THIS CONTROL DRAWING IS PERMITTED WITHOUT AUTHORIZATION FROM THE NOTIFIED BODY.
- 15. For release approvals see ECO # 0049814

XYR 6000 STIW600	Field Transmitter	Associated Apparatus
$U_i = 30 \text{ V}$	$U_i \geq$	$U_o \leq 30 \text{ V}$
$I_i = 125 \text{ mA}$	$I_i \geq$	$I_o \leq 125 \text{ mA}$
$P_i = 1.0 \text{ W}$	$P_i \geq P_o$	$P_o \leq \frac{(V_{oc} \text{ or } V_t \cdot I_{sc} \text{ or } I_t)}{4} \leq 1.0 \text{ W}$
$C_i = 6.4 \text{ nF}$	$C_i \leq$ Associated Apparatus $C_o - C_{cable} - C_i$ of other transmitter connected to two-channel barrier.	$C_o > 6.4 \text{ nF}$
$L_i = 1.0 \mu\text{H}$	$L_i \leq$ Associated Apparatus $L_o - L_{cable} - L_i$ of other transmitter connected to two-channel barrier.	$L_o > 1.0 \mu\text{H}$

Honeywell	A/A4	50033269		
	SCALE NONE	REV: F	DATE: 26 March 2012	SH.2 of 12

**ATEX CERTIFIED INTRINSICALLY SAFE (ia) AND NON-SPARKING (n)
 INSTALLATION CONTROL DRAWING – TWO-WIRE CONFIGURATION**

XYR 6000, STIW600, 0–20 mA / 4–20 mA HIGH LEVEL INPUT INTERFACE

**NON-HAZARDOUS
 LOCATION**

ASSOCIATED APPARATUS
 IS FIELD WIRING
 PARAMETERS

$U_o \leq 30\text{ V}$
 $I_o \leq 125\text{ mA}$
 $P_o \leq 1.0\text{ W}$
 $C_o \geq C_{\text{cable}} + C_{\text{Field Transmitter}} + 6.4\text{ nF}$
 $L_o \geq L_{\text{cable}} + L_{\text{Field Transmitter}} + 1.0\text{ }\mu\text{H}$

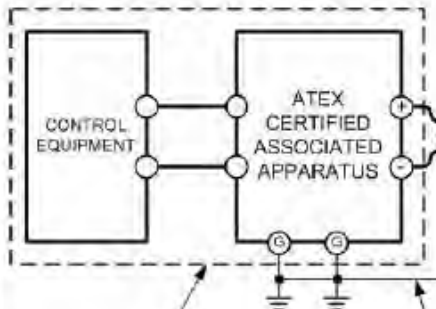

ZONE 2 CONTROL EQUIPMENT
 Ex nL OUTPUT PARAMETERS

$U_o \leq 30\text{ V}$
 $I_o \leq 125\text{ mA}$
 $P_o \leq 1.0\text{ W}$
 $C_o \geq C_{\text{cable}} + C_{\text{Field Transmitter}} + 6.4\text{ nF}$
 $L_o \geq L_{\text{cable}} + L_{\text{Field Transmitter}} + 1.0\text{ }\mu\text{H}$

GROUND SHIELD AT
 THIS END ONLY

HAZARDOUS LOCATION

XYR 6000 WIRELESS TRANSMITTER

Ex ia IIB; T4 Ta ≤ 70°C; Ex tD A20 IP66 T90°C
 Ex nA [nL] IIC; T4 Ta ≤ 84°C (≤ 80°C WITH OPTION DC)
 Ex tD A22 IP66 T90°C
 AMBIENT LIMITS: -30°C ≤ Ta ≤ 84°C
 (≤ 80°C WITH OPTION DC)

ENTITY PARAMETERS

$U_i = 30\text{ V}$
 $I_i = 125\text{ mA}$
 $P_i = 1.0\text{ W}$
 $C_i = 6.4\text{ nF}$
 $L_i = 1.0\text{ }\mu\text{H}$

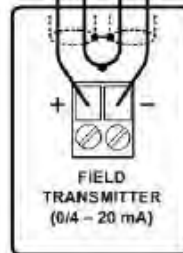
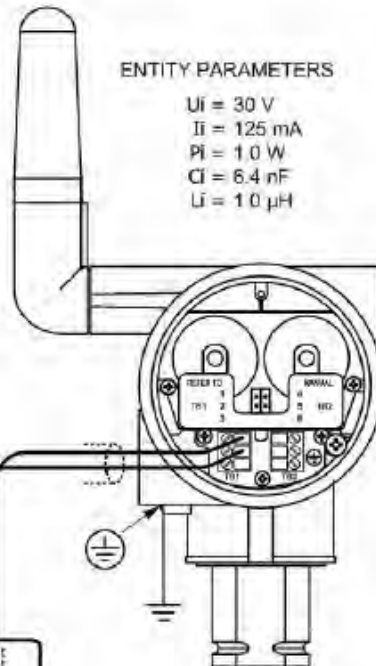

FIELD TRANSMITTER
 SHALL BE ATEX CERTIFIED
 INTRINSICALLY SAFE FOR USE IN ZONE
 0 / 1 LOCATIONS, OR NON-SPARKING,
 Ex nA FOR USE IN ZONE 2 LOCATIONS

Honeywell

A/A4

50033269

SCALE NONE

REV: F

DATE: 26 March 2012

SH.3 of 12

**WIRELESS TEMPERATURE AND DIGITAL INPUT(DI) TRANSMITTERS
 STTW400, STTW401, STXW500, STT820, STTW830 & STTW840**

HAZARDOUS LOCATION

Ex ib [ia] IIB; T4 Ta = 70°C; DIP A20 IP66 T90°C (WITH OPTION BA)

Ex nA [nL] IIC; T4 Ta = 84°C; DIP A22 IP66 T90°C (< 80°C WITH OPTION DC)

AMBIENT LIMITS: -40 < Ta < 84°C (< 80°C WITH OPTION DC)

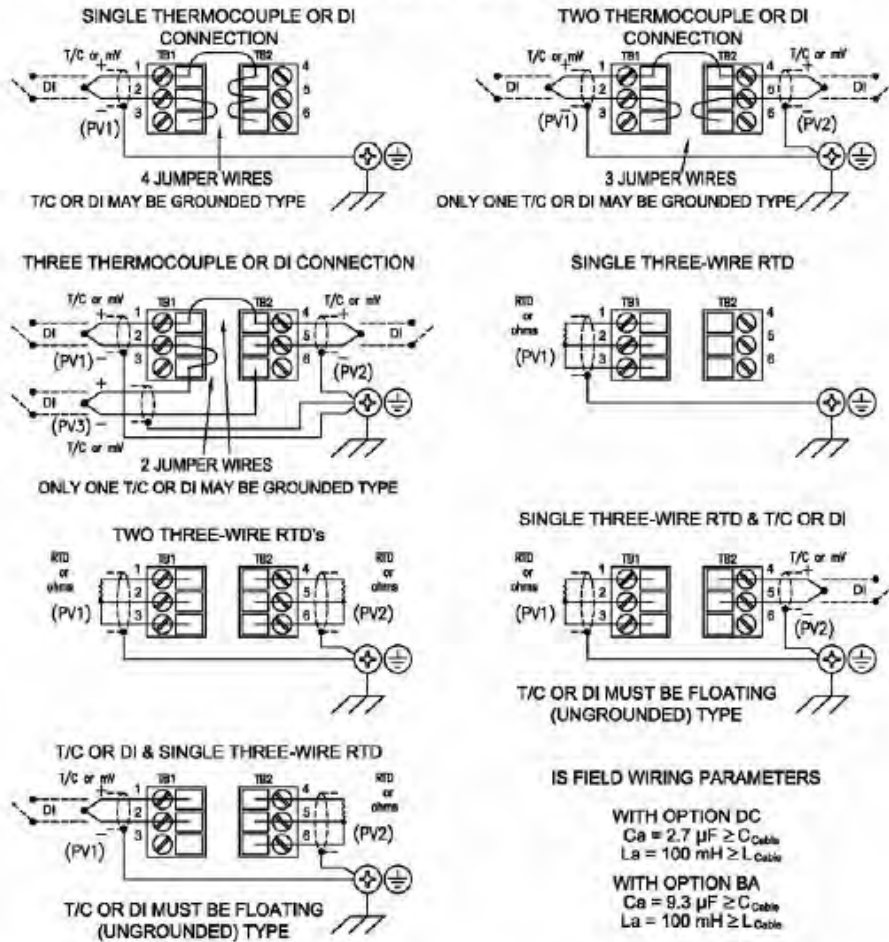

NOTES:

1. Shielded thermocouple/mV or RTD/Ohms cable is required for EMC conformity and is recommended for all remote sensor installations. The shield shall be grounded at the transmitter end only.
2. When remote mounted probe sensors are used and the shield is grounded at the probe, the shield shall not be connected at the transmitter end.
3. Duplex (redundant) sensors that are bonded to the probe are not permitted. All thermocouple/mV inputs and RTD/Ohms inputs must be insulated from ground (the probe) and from each other as noted above.
4. Jumper wires the same gauge and stranding as the thermocouple wires are required for single and dual thermocouple input combinations.
5. Digital input switches, DI, must be dry contact type, simple apparatus and properly segregated from all other sources of power.

Honeywell	A/A4	50033269		
	SCALE NONE	REV: F	DATE: 26 March 2012	SH.4 of 12

WIRELESS TEMPERATURE AND DIGITAL INPUT (DI) TRANSMITTERS

STTW400, STTW401, STXW500, STTW820, STTW830 & STTW840

HAZARDOUS LOCATION

Ex ib [ia] IIB; T4 Ta = 70°C; DIP A20 IP66 T90°C (WITH OPTION BA)

Ex nA [nL] IIC; T4 Ta = 84°C; DIP A22 IP66 T90°C (< 80°C WITH OPTION DC)

AMBIENT LIMITS: -40 < Ta < 84°C (< 80°C WITH OPTION DC)

SINGLE TWO-WIRE RTD

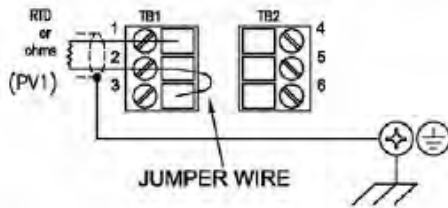

TWO TWO-WIRE RTD

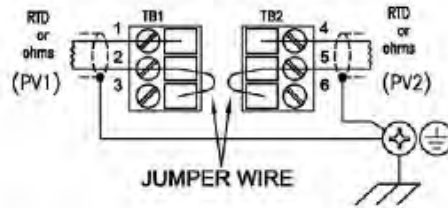

T/C OR DI & SINGLE TWO-WIRE RTD

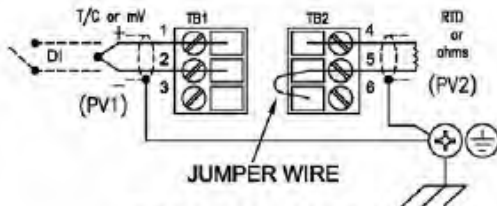

T/C OR DI MUST BE FLOATING (UNGROUND) TYPE

SINGLE TWO-WIRE RTD & T/C OR DI

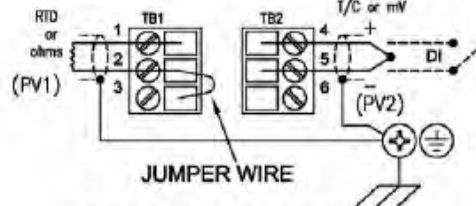

T/C OR DI MUST BE FLOATING (UNGROUND) TYPE

IS FIELD WIRING PARAMETERS

WITH OPTION DC

Ca = 2.7 μF ≥ C_{Cable}
 La = 100 mH ≥ L_{Cable}

WITH OPTION BA

Ca = 9.3 μF ≥ C_{Cable}
 La = 100 mH ≥ L_{Cable}

NOTES:

1. Shielded thermocouple/mV or RTD/Ohms cable is required for EMC conformity and is recommended for all remote sensor installations. The shield shall be grounded at the transmitter end only.
2. When remote mounted probe sensors are used and the shield is grounded at the probe, the shield shall not be connected at the transmitter end.
3. Duplex (redundant) sensors that are bonded to the probe are not permitted. All thermocouple/mV inputs and RTD/Ohms inputs must be insulated from ground (the probe) and from each other as noted above.
4. Jumper wires the same gauge and stranding as the thermocouple wires are required for single and dual thermocouple input combinations.
5. Digital input switches, DI, must be dry contact type, simple apparatus and properly segregated from all other sources of power.

Honeywell

A/A4

50033269

SCALE NONE

REV: F

DATE: 26 March 2012

SH.5 of 12

WIRELESS UNIVERSAL I/O - STUW700 & STUW701

HAZARDOUS LOCATION

Ex ia IIB; T4 Ta ≤ 70°C; Ex tD A20 IP66 T90°C

Ex nA [nL] IIC; T4 Ta ≤ 84°C (≤ 80°C WITH OPTION DC) Ex tD A22 IP66 T90°C

AMBIENT LIMITS: -40°C ≤ Ta ≤ 84°C (≤ 80°C WITH OPTION DC)

STUW700 - POSSIBLE CONNECTIONS T/C, mV, DIGITAL INPUT (DI) AND HIGH LEVEL ANALOG INPUT (HLAI)

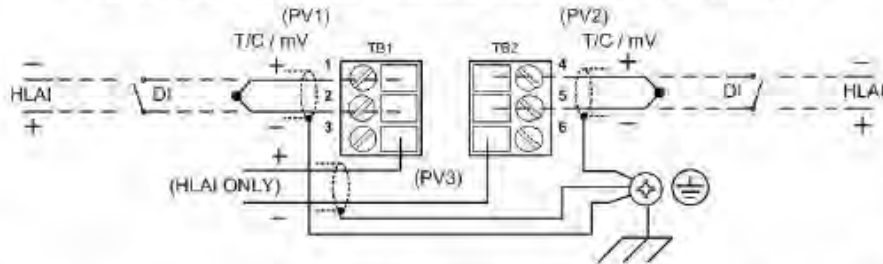

STUW701 - POSSIBLE CONNECTIONS T/C, mV, DIGITAL INPUT (DI), HIGH LEVEL ANALOG INPUT (HLAI) AND DIGITAL OUTPUT (DO)

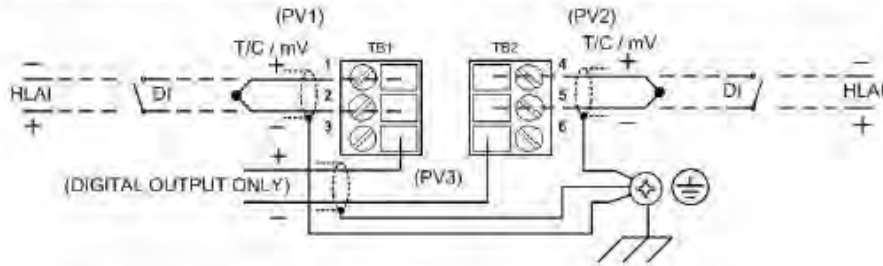

HIGH LEVEL ANALOG INPUT & DIGITAL OUTPUT ENTITY PARAMETERS

U_i (Vmax) = 30 V
 I_i (Imax) = 125 mA
 P_i = 1.0 W
 C_i = 6.8 nF
 L_i = 0.1 μH

DIGITAL INPUT AND T/C FIELD WIRING PARAMETERS

C_a = 100 μF ≥ C_{Cable}
 L_a = 100 mH ≥ L_{Cable}

NOTES:

1. Shielded HLAI, DI, DO, thermocouple, mV, or switch input cable is required for EMC conformity and is recommended for all installations. The shield shall be grounded at the transmitter end only. If the shield is grounded at the switch, remote HLAI transmitter location, or remote DO supply the shield shall not be connected at the Wireless transmitter end.

Honeywell

A/A4

50033269

SCALE NONE

REV: F

DATE: 26 March 2012

SH.6 of 12

XYR 6000, MODEL CETW6000M
WIRELESS CORROSION TRANSMITTER

Ex ia IIB; T4 Ta ≤ 70°C; Ex tD A20 IP66 T90°C
 Ex nA [nL] IIC; T4 Ta ≤ 84°C (≤ 80°C WITH OPTION DC)
 Ex tD A22 IP66 T90°C
 AMBIENT LIMITS: -30°C ≤ Ta ≤ 84°C (≤ 80°C WITH OPTION DC)

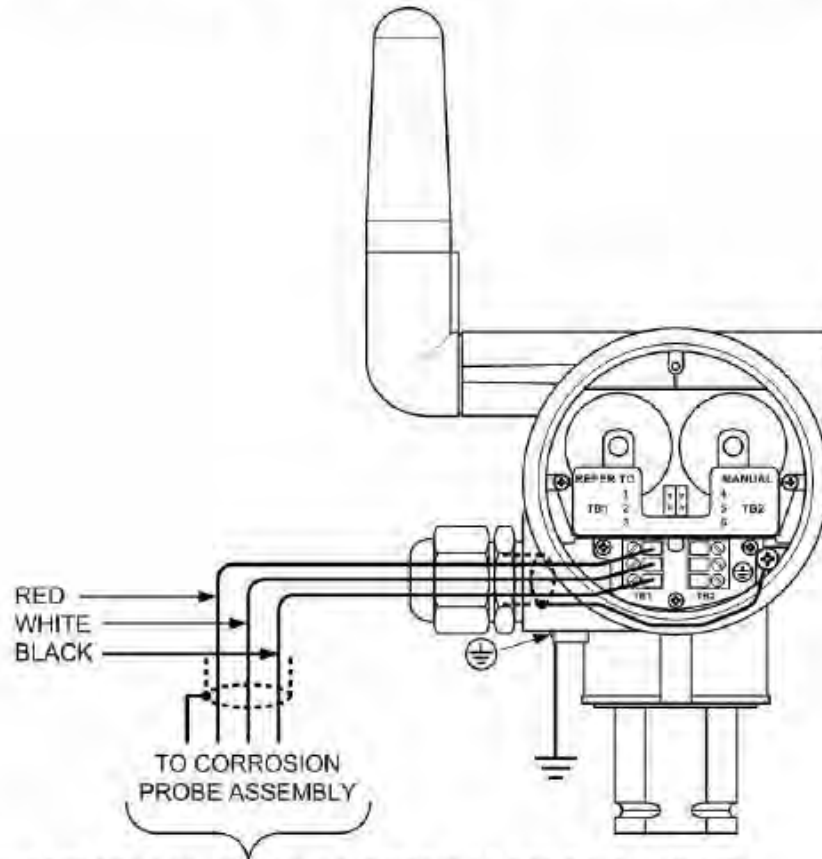

PROBE AND PROCESS ELECTRODES MUST BE PASSIVE
 ELEMENTS ONLY. PROBE AND CABLE PARAMETERS
 MUST NOT EXCEED $43 \mu\text{F} \geq C_{\text{PROBE}} + C_{\text{CABLE}}$ AND
 $0.25 \text{ mH} \geq L_{\text{PROBE}} + L_{\text{CABLE}}$

NOTE: Probe used with the Corrosion Transmitter must be acceptable to the competent body having jurisdiction with respect to pressure and temperature rating.

Honeywell	A/A4	50033269		
	SCALE NONE	REV: F	DATE: 26 March 2012	SH.7 of 12

6. Certification Installation Requirements
 Certification Drawings

The following models may be supplied with internal battery power, or externally supplied 24Vdc only when connected to the MTL Associated Apparatus listed on the following system diagram.

NOTE: XYR 6000 ambient limits with 24V Power Supply are -40°C to +80°C.

Model	Description	
STGW944	Series 900 Wireless Transmitter, Dual Head Gage Pressure (GP)	0-500 psi / 0-35 bar
STGW974		0-3000 psi / 0-210 bar
STDW924	Series 900 Wireless Transmitter, Differential Pressure (DP)	0-400" H ₂ O / 0-1000 mbar
STDW930		0-100 psi / 0-7 bar
STDW974		0-3000 psi / 0-210 bar
STGW94L	Series 900 Wireless Transmitter, In-Line Gage & Absolute Pressure	0-500 psi / 0-35 bar
STGW97L		0-3000 psi / 0-210 bar
STGW98L		0-6000 psi / 0-415 bar
STGW99L		0-10,000 psig / 0-690 bar
STAW94L		0-500 psi / 0-35 barA
STFW924	Flanged Series 900 Wireless Pressure Transmitter	0- 400" H ₂ O/ 0- 1000 mbar Compound Characterized
STFW932		0- 100 psi/ 0- 7 bar Compound Characterized
STRW93D	Series 900 Wireless Transmitter, Dual Pressure & Gage Pressure Remote Seals	0- 2700" H ₂ O/ 0- 7 bar Compound Characterized
STRW94G		0- 500 psi/ 0- 35 bar
STFW92F	In-Line Flanged Series 900 Wireless Transmitter	0- 400" H ₂ O/ 0- 1000 mbar
STFW93F		0- 100 psi/ 0- 7 bar
STDW120	Series 100 Wireless Transmitter, Differential Pressure (DP)	0- 400" H ₂ O/ 0- 1000 mbar
STDW125		0- 600" H ₂ O/ 0- 1500 mbar
STDW130		0- 100 psi/ 0- 7 bar
STDW170		0- 3000 psi/ 0-210 bar
STGW14L	Series 100 Wireless Transmitter, In-Line Gage Pressure	0- 500 psi/ 0- 35 bar
STGW17L		0- 3000 psi/ 0- 210 bar
STGW18L		0- 6000 psi/ 0- 415 bar
STGW19L		0- 10000 psi/ 0- 690 bar
STAW14L	Series 100 Wireless Transmitter, In-Line Absolute Pressure	0- 500 psia/ 0- 35 barA
STAW140	Series 100 Wireless Transmitter, Single Head Absolute Pressure	0- 500 psia/ 0- 35 barA
STFW128	Flanged Series 100 Wireless Pressure Transmitter	0- 400" H ₂ O/ 0- 1000 mbar Compound Characterized
STFW132		0- 100 psi/ 0- 7 bar Compound Characterized
STFW12F		0- 400" H ₂ O/ 0- 1000 mbar
STFW13F		0- 100 psi/ 0- 7 bar
STFW14F		0- 600" H ₂ O/ 0- 1500 mbar
STRW12D	Series 100 Wireless Transmitter, Dual Pressure, Gage Pressure and Absolute Remote Seals	0- 400" H ₂ O/ 0- 1000 mbar Compound Characterized
STRW13D		0- 100 psi/ 0- 7 bar
STRW14A		0- 500 psia/ 0- 35 barA
STRW14G		0- 500 psi/ 0- 35 bar
STRW17G		0- 100 psi/ 0- 7 bar
STTW400	Wireless Temperature Transmitter	Transmitter Only with Remote Sensors:

Honeywell

A/A4

50033269

SCALE NONE

REV: F

DATE: 26 March 2012

SH.8 of 12

Model	Description	
		3 T/C's, or 2 RTD's
STTW401	Wireless Temperature and Digital Input Transmitter	Transmitter Only with Remote Sensors: 1 T/C AND 2 Digital Inputs
STXW500	Wireless Digital Input Transmitter	Three DI (Switch) Inputs
STUW700	Wireless Universal I/O Interface	Three Inputs: 4-20 mA Analog, T/C's, or DI (Switch)
STUW701	Wireless Universal I/O Interface	Two Inputs: 4-20 mA Analog, T/C or DI and One Digital Output (Solid State)
STTW820 STTW830 STTW840	Wireless Temperature Transmitter	Transmitter Integrally Mounted to Thermowell or Probe Assembly
STIW600	Wireless High Level Input Interface	4-20 mA Analog Input
CETW6000M-W	SmartCET Wireless Transmitter, Corrosion Monitoring	Millivolt Input from Remote Mounted Corrosion Probe
CETW6000M-D	SmartCET Corrosion Data Logger	Millivolt Input from Remote Mounted Corrosion Probe, Data via IrDA Port *

* There is no Antenna for this version

The above listed wireless transmitters may include an Omni-directional or unidirectional high-gain antenna. The high-gain antenna may be installed remote from the XYR 6000 with the cable length not to exceed 20m. The antenna cable shield shall be bonded to earth ground.

IS Entity parameters for remote antennas, cables & lightning arrestor:
Ca = 43 µF, La = 0.1 mH.

Honeywell	A/A4	50033269		
	SCALE NONE	REV: F	DATE: 26 March 2012	SH.9 of 12

24Vdc IS POWER SUPPLY OPTION (DC)

(SYSTEM DIAGRAM)

HAZARDOUS LOCATION

Ex ia IIB; T4 Ta = 70°C; DIP A20 IP66 T90°C
 Ex nA [nL] IIC; T4 Ta = 80°C; DIP A22 IP66 T90°C
 AMBIENT LIMITS: $-40 < T_a < 80^\circ\text{C}$

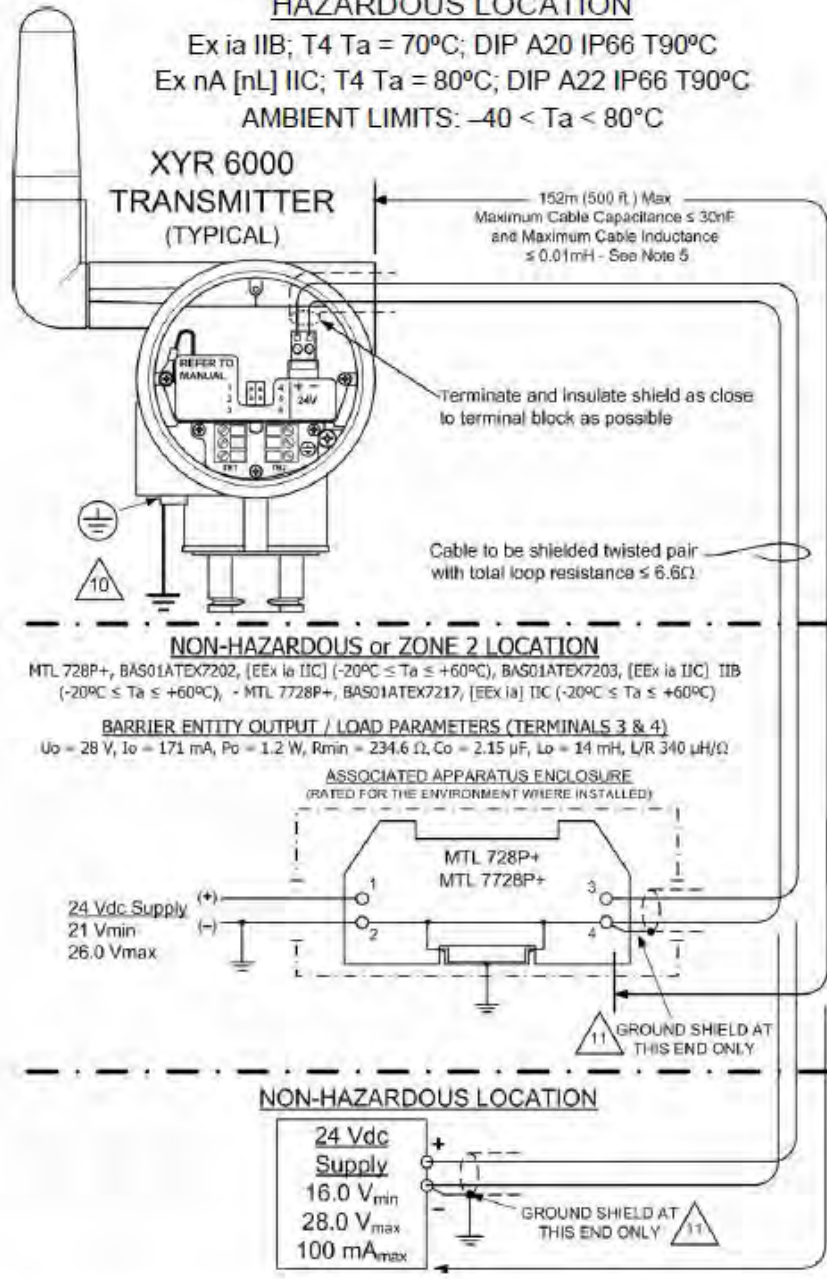

Honeywell

A/A4

50033269

SCALE NONE

REV: F

DATE: 26 March 2012

SH.10 of 12

**REMOTE ANTENNAS MUST BE
 PASSIVE ELEMENTS ONLY**

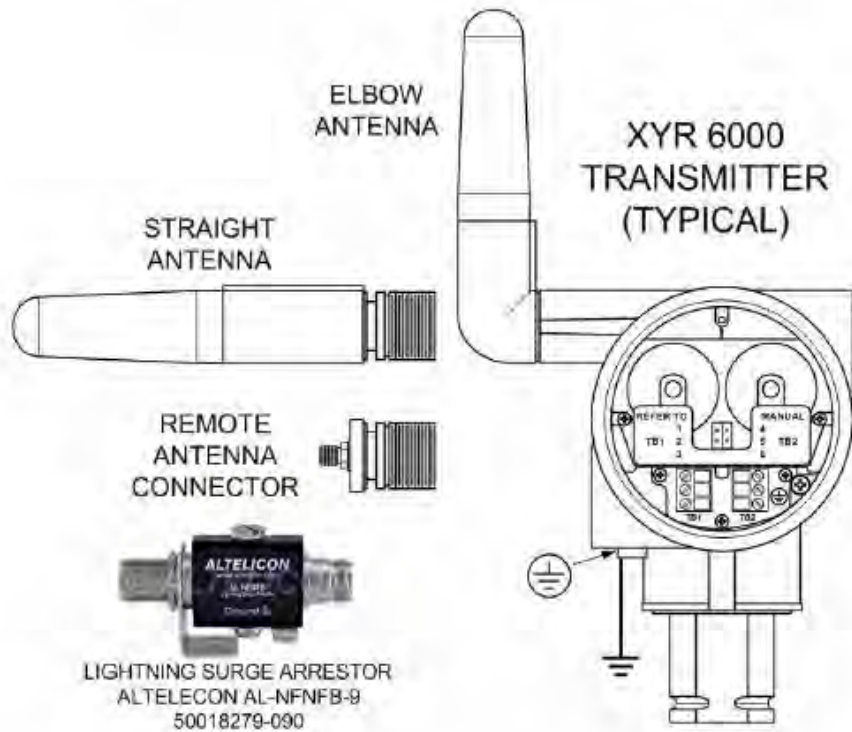

Honeywell

A/A4

50033269

SCALE NONE

REV: F

DATE: 26 March 2012

SH.11 of 12

6. Certification Installation Requirements
 Certification Drawings

IS parameters for remote antennas, cables & lightning arrestor.
 $C_a = 43 \mu\text{F}$, $L_a = 0.1 \text{ mH}$.

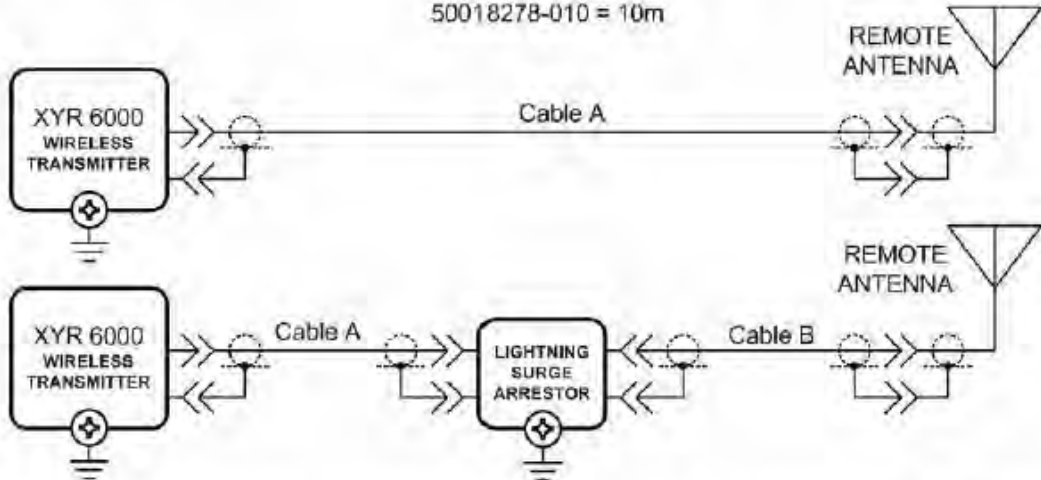
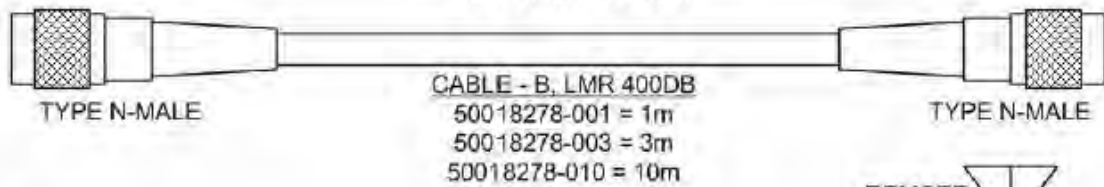
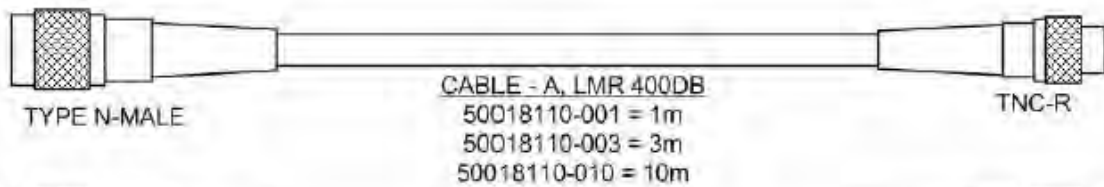

CABLE PARAMETERS			LIGHTNING SURGE ARRESTOR PARAMETERS
CABLE A, B LENGTH	CAPACITANCE	INDUCTANCE	
1 m	78.4 pF	0.2 μH	CAPACITANCE = 1 pF INDUCTANCE = 10 nH
3 m	235.2 pF	0.6 μH	
10 m	784 pF	2.0 μH	

Honeywell

A/A4

50033269

SCALE NONE

REV: F

DATE: 26 March 2012

SH.12 of 12

IECEX Control Drawings

COPYRIGHT 2012, HONEYWELL INTERNATIONAL INC. NEITHER THIS DOCUMENT NOR THE INFORMATION CONTAINED HEREIN SHALL BE REPRODUCED, USED OR DISCLOSED TO OTHERS WITHOUT THE WRITTEN AUTHORIZATION OF HONEYWELL. USE, DUPLICATION, OR DISCLOSURE OF THIS DOCUMENT IS SUBJECT TO THE RESTRICTIONS SET FORTH IN A WRITTEN AGREEMENT. NOTHING CONTAINED HEREIN SHALL BE CONSTRUED AS CONFERRING BY IMPLICATION, ESTOPPEL, OR OTHERWISE ANY LICENSE TO ANY PATENT, TRADEMARK, COPYRIGHT OR OTHER INTELLECTUAL PROPERTY RIGHT OF HONEYWELL OR ANY THIRD PARTY.	ISS	REVISION & DATE	APPD
	E	27 March 2012 ECO-0069377	VM

IECEX INTRINSICALLY SAFE (ia) AND NON-SPARKING (n) INSTALLATION CONTROL DRAWING XYR 6000 WIRELESS TRANSMITTERS

NOTES:

1. Electrical apparatus and circuits can be used in zone 0 if they are in accordance with IEC 60079-11 (category "ia" – intrinsic safety), the applicable parts of IEC 60079-0 and with the requirements of IEC 60079-14, 12.3 (see also 5.2.4).
2. Electrical apparatus and circuits can be used in zone 2 if they are in accordance with IEC 60079-15, the applicable parts of IEC 60079-0 and with the requirements of IEC 60079-14, 12.2.
3. IECEx certified intrinsically safe apparatus shall be installed in accordance with the manufacturer's Intrinsic Safety Control Drawing or shall be Simple Apparatus. Simple Apparatus are devices that will neither generate nor store more than 1.2V, 0.1A, 25mW, or 20µJ, such as switches, thermocouples, and RTDs. IECEx certified non-sparking apparatus shall be installed per this control drawing.
4. Intrinsic Safety system parameters shall comply with the following:
 $U_o \leq U_i$, $I_o \leq I_i$, $C_o \geq C_i + C_{cable}$, $L_o \geq L_i + L_{cable}$, $P_o \leq P_i$. Where two separate barrier channels are required, one dual-channel or two single-channel barriers may be used, where in either case, both channels have been Certified for use together with combined entity parameters that meet the above equations.
5. System Parameters:
 XYR 6000 and Field Transmitter $U_i \geq U_o$, $I_i \geq I_o$;
 XYR 6000 $C_i + \text{Field Transmitter } C_i + C_{cable} \leq \text{Associated Apparatus } C_o$,
 XYR 6000 $L_i + \text{Field Transmitter } L_i + L_{cable} \leq \text{Associated Apparatus } L_o$.
6. When the electrical parameters of the cable are unknown, the following values may be used: Capacitance – 197pF/m, Inductance – 0.66µH/m.
7. For IECEx 60079-0 Ex II/III installations where rigid metal conduit is not used, seal cable entries against dust and fibers using a certified cable gland fitting.
8. Control equipment that is connected to associated apparatus must not use or generate more than 250 V.
9. Associated apparatus must be IECEx certified. Associated apparatus may be installed in a Zone 2 location if so approved.
10. Non-Galvanically isolated apparatus (grounded Zener Barriers) must be connected to a suitable ground electrode per IEC 60079-14, Clause 12.2.4. The resistance of the ground path must be less than 1.0 ohm.
11. Shielded two-wire cable is required for EMC conformity and is recommended for all installations. The 4-20 mA loop shield shall be grounded at the supply (barrier) end to the barrier ground bus only when grounded Zener barriers are used. The 4-20 mA loop shield shall be grounded at the transmitter end only when galvanically isolated barriers are used.

MASTER FILE TYPE: MS WORD

CERTIFICATION DOCUMENT ENGINEERING CHANGE ORDERS (ECOs) MUST BE AUTHORIZED BY APPROVALS ENGINEERING	DRAWN	F.Kent	Honeywell		
	CHECKED				
	DEV ENG	NOTE 15	IECEX Control Drawing XYR 6000 Wireless Transmitters Zones 0, 1 & 2		
	MFG ENG		A A4	50036277	
	QA ENG				
	TOLERANCE UNLESS NOTED				
ANGULAR DIMENSION		SCALE	USED ON	SH.1 OF 11	

6. Certification Installation Requirements
 Certification Drawings

- 12. Zone 0 or Zone 1: WARNING: EXPLOSION HAZARD – SUBSTITUTION OF COMPONENTS MAY IMPAIR SUITABILITY FOR USE IN HAZARDOUS LOCATIONS.
- 13. Zone 2: WARNING: EXPLOSION HAZARD – DO NOT DISCONNECT EQUIPMENT UNLESS POWER HAS BEEN SWITCHED OFF OR THE AREA IS KNOWN TO BE NON-HAZARDOUS.
- 14. NO REVISION OF THIS CONTROL DRAWING IS PERMITTED WITHOUT AUTHORIZATION FROM THE NOTIFIED BODY.
- 15. For release approvals see ECO # 0049814.

XYR 6000 STIW600	Field Transmitter	Associated Apparatus
$U_i = 30 \text{ V}$	$U_i \geq$	$U_o \leq 30 \text{ V}$
$I_i = 125 \text{ mA}$	$I_i \geq$	$I_o \leq 125 \text{ mA}$
$P_i = 1.0 \text{ W}$	$P_i \geq P_o$	$P_o \leq \frac{(V_{oc} \text{ or } V_t \cdot I_{sc} \text{ or } I_t)}{4} \leq 1.0 \text{ W}$
$C_i = 6.4 \text{ nF}$	$C_i \leq$ Associated Apparatus $C_o - C_{cable} - C_i$ of other transmitter connected to two-channel barrier.	$C_o > 6.4 \text{ nF}$
$L_i = 1.0 \mu\text{H}$	$L_i \leq$ Associated Apparatus $L_o - L_{cable} - L_i$ of other transmitter connected to two-channel barrier.	$L_o > 1.0 \mu\text{H}$

Honeywell	A/A4	50036277	
	SCALE NONE	REV: E DATE 27 March 2012	SH. 2 of 11

**IECEX CERTIFIED INTRINSICALLY SAFE (ia) AND NON-SPARKING (n)
 INSTALLATION CONTROL DRAWING – TWO-WIRE CONFIGURATION**
XYR 6000, STIW600, 0–20 mA / 4–20 mA HIGH LEVEL INPUT INTERFACE

**NON-HAZARDOUS
 LOCATION**

ASSOCIATED APPARATUS
 IS FIELD WIRING
 PARAMETERS

$U_o \leq 30\text{ V}$
 $I_o \leq 125\text{ mA}$
 $P_o \leq 1.0\text{ W}$
 $C_o \geq C_{\text{cable}} + C_{\text{Field Transmitter}} + 6.4\text{ nF}$
 $L_o \geq L_{\text{cable}} + L_{\text{Field Transmitter}} + 1.0\text{ }\mu\text{H}$

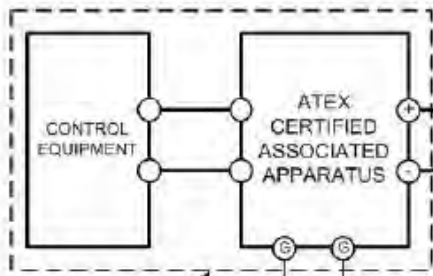

ZONE 2 CONTROL EQUIPMENT
 Ex nL OUTPUT PARAMETERS

$U_o \leq 30\text{ V}$
 $I_o \leq 125\text{ mA}$
 $P_o \leq 1.0\text{ W}$
 $C_o \geq C_{\text{cable}} + C_{\text{Field Transmitter}} + 6.4\text{ nF}$
 $L_o \geq L_{\text{cable}} + L_{\text{Field Transmitter}} + 1.0\text{ }\mu\text{H}$

GROUND SHIELD AT
 THIS END ONLY

HAZARDOUS LOCATION

XYR 6000 WIRELESS TRANSMITTER
 Ex ia IIB; T4 Ta = 70°C; DIP A20 IP66 T90°C
 Ex nA [nL] IIC; T4 Ta = 84°C; DIP A22 IP66 T90°C
 (≤ 80°C WITH OPTION DC)
 AMBIENT LIMITS: -40 ≤ Ta ≤ 84°C
 (≤ 80°C WITH OPTION DC)

ENTITY PARAMETERS

$U_i = 30\text{ V}$
 $I_i = 125\text{ mA}$
 $P_i = 1.0\text{ W}$
 $C_i = 6.4\text{ nF}$
 $L_i = 1.0\text{ }\mu\text{H}$

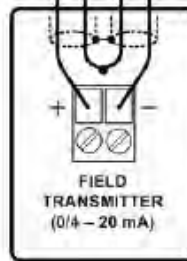
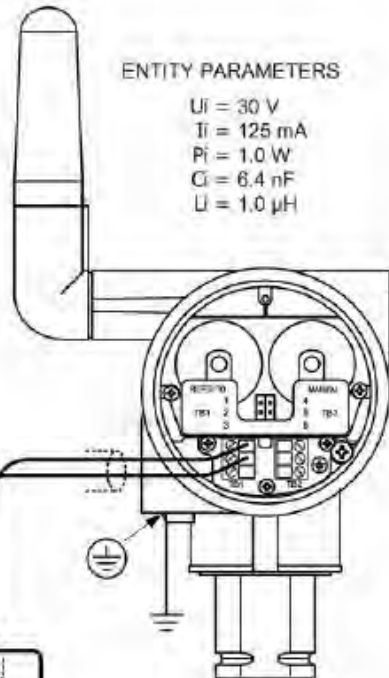

FIELD TRANSMITTER
 SHALL BE CERTIFIED INTRINSICALLY
 SAFE FOR USE IN ZONE 0 / 1
 LOCATIONS, OR NON-SPARKING,
 Ex nA FOR USE IN ZONE 2 LOCATIONS

Honeywell

A/A4

50036277

SCALE NONE

REV: E DATE 27 March 2012

SH. 3 of 11

**WIRELESS TEMPERATURE AND DIGITAL INPUT(DI) TRANSMITTERS
 STTW400, STTW401, STXW500, STT820, STTW830 & STTW840**

HAZARDOUS LOCATION

Ex ib [ja] IIB; T4 Ta = 70°C; DIP A20 IP66 T90°C (WITH OPTION BA)
 Ex nA [nL] IIC; T4 Ta = 84°C; DIP A22 IP66 T90°C (< 80°C WITH OPTION DC)
AMBIENT LIMITS: -40 < Ta < 84°C (< 80°C WITH OPTION DC)

SINGLE THERMOCOUPLE OR DI CONNECTION

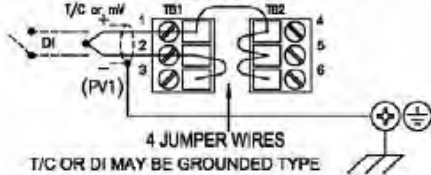

4 JUMPER WIRES
 T/C OR DI MAY BE GROUNDED TYPE

TWO THERMOCOUPLE OR DI CONNECTION

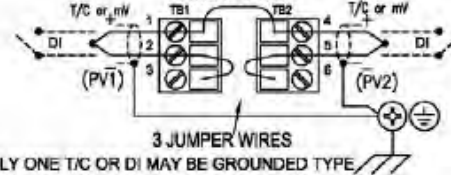

3 JUMPER WIRES
 ONLY ONE T/C OR DI MAY BE GROUNDED TYPE

THREE THERMOCOUPLE OR DI CONNECTION

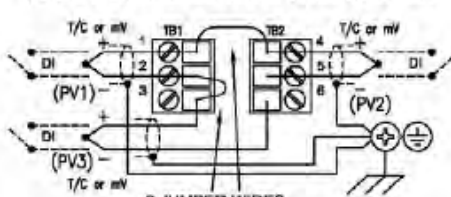

2 JUMPER WIRES
 ONLY ONE T/C OR DI MAY BE GROUNDED TYPE

SINGLE THREE-WIRE RTD

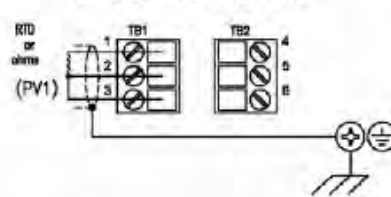

SINGLE THREE-WIRE RTD & T/C OR DI

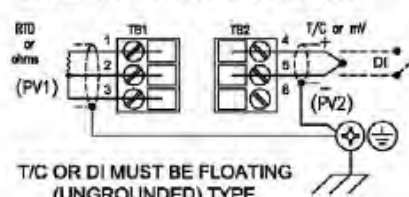

T/C OR DI MUST BE FLOATING (UNGROUND) TYPE

TWO THREE-WIRE RTD's

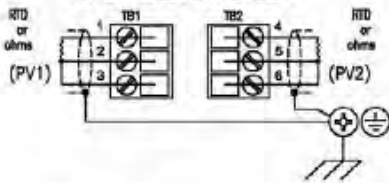

T/C OR DI & SINGLE THREE-WIRE RTD

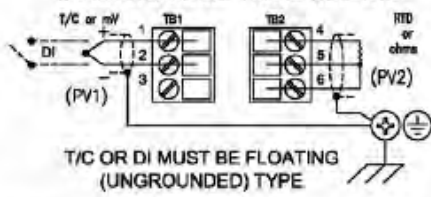

T/C OR DI MUST BE FLOATING (UNGROUND) TYPE

IS FIELD WIRING PARAMETERS

WITH OPTION DC
 $C_a = 2.7 \mu F \geq C_{Cable}$
 $L_a = 100 mH \geq L_{Cable}$

WITH OPTION BA
 $C_a = 9.3 \mu F \geq C_{Cable}$
 $L_a = 100 mH \geq L_{Cable}$

NOTES:

1. Shielded thermocouple/mV or RTD/Ohms cable is required for EMC conformity and is recommended for all remote sensor installations. The shield shall be grounded at the transmitter end only.
2. When remote mounted probe sensors are used and the shield is grounded at the probe, the shield shall not be connected at the transmitter end.
3. Duplex (redundant) sensors that are bonded to the probe are not permitted. All thermocouple/mV inputs and RTD/Ohms inputs must be insulated from ground (the probe) and from each other as noted above.
4. Jumper wires the same gauge and stranding as the thermocouple wires are required for single and dual thermocouple input combinations.
5. Digital input switches, DI, must be dry contact type, simple apparatus and properly segregated from all other sources of power.

Honeywell

A/A4

50036277

SCALE NONE

REV: E DATE 27 March 2012

SH. 4 of 11

**WIRELESS TEMPERATURE AND DIGITAL INPUT(DI) TRANSMITTERS
 STTW400, STTW401, STXW500, STT820, STTW830 & STTW840**

HAZARDOUS LOCATION

Ex ib [ia] IIB; T4 Ta = 70°C; DIP A20 IP66 T90°C (WITH OPTION BA)
 Ex nA [nL] IIC; T4 Ta = 84°C; DIP A22 IP66 T90°C (< 80°C WITH OPTION DC)
AMBIENT LIMITS: -40 < Ta < 84°C (< 80°C WITH OPTION DC)

SINGLE TWO-WIRE RTD

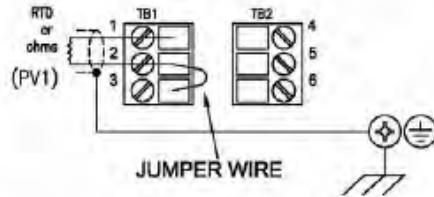

TWO TWO-WIRE RTD

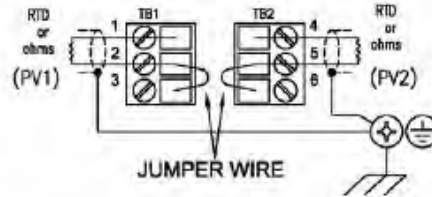

T/C OR DI & SINGLE TWO-WIRE RTD

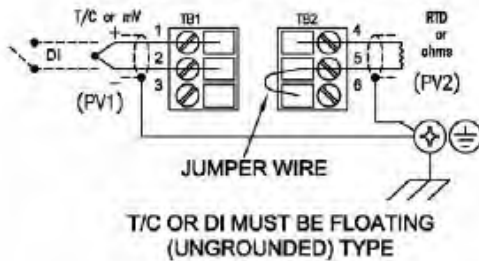

SINGLE TWO-WIRE RTD & T/C OR DI

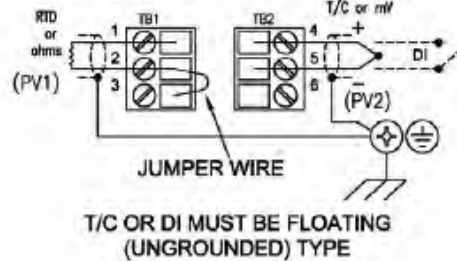

IS FIELD WIRING PARAMETERS

WITH OPTION DC
 $C_a = 2.7 \mu F \geq C_{Cable}$
 $L_a = 100 \text{ mH} \geq L_{Cable}$

WITH OPTION BA
 $C_a = 9.3 \mu F \geq C_{Cable}$
 $L_a = 100 \text{ mH} \geq L_{Cable}$

NOTES:

1. Shielded thermocouple/mV or RTD/Ohms cable is required for EMC conformity and is recommended for all remote sensor installations. The shield shall be grounded at the transmitter end only.
2. When remote mounted probe sensors are used and the shield is grounded at the probe, the shield shall not be connected at the transmitter end.
3. Duplex (redundant) sensors that are bonded to the probe are not permitted. All thermocouple/mV inputs and RTD/Ohms inputs must be insulated from ground (the probe) and from each other as noted above.
4. Jumper wires the same gauge and stranding as the thermocouple wires are required for single and dual thermocouple input combinations.
5. Digital input switches, DI, must be dry contact type, simple apparatus and properly segregated from all other sources of power.

Honeywell

A/A4

50036277

SCALE NONE

REV: E DATE 27 March 2012

SH. 5 of 11

WIRELESS UNIVERSAL I/O - STUW700 & STUW701

HAZARDOUS LOCATION

Ex ia IIB; T4 Ta ≤ 70°C; DIP A20 IP66 T90°C

Ex nA [nL] IIC; T4 Ta ≤ 84°C (≤ 80°C WITH OPTION DC) DIP A22 IP66 T90°C

AMBIENT LIMITS: -40 ≤ Ta ≤ 84°C (≤ 80°C WITH OPTION DC)

STUW700 - POSSIBLE CONNECTIONS T/C, mV, DIGITAL INPUT (DI) AND HIGH LEVEL ANALOG INPUT (HLAI)

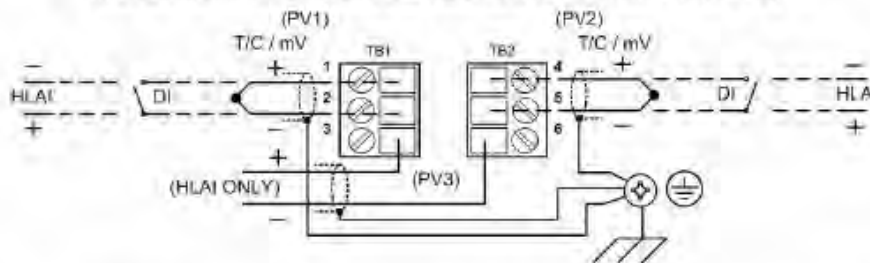

STUW701 - POSSIBLE CONNECTIONS T/C, mV, DIGITAL INPUT (DI), HIGH LEVEL ANALOG INPUT (HLAI) AND DIGITAL OUTPUT (DO)

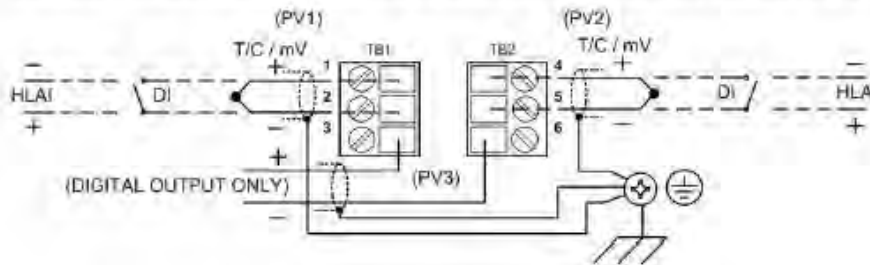

HIGH LEVEL ANALOG INPUT & DIGITAL OUTPUT ENTITY PARAMETERS

U_i (V_{max}) = 30 V
 I_i (I_{max}) = 125 mA
 P_i = 1.0 W
 C_i = 6.8 nF
 L_i = 0.1 μH

DIGITAL INPUT AND T/C FIELD WIRING PARAMETERS

C_a = 2.7 μF ≥ C_{Cable}
 L_a = 100 mH ≥ L_{Cable}

NOTES:

1. Shielded HLA I, DI, DO, thermocouple, mV, or switch input cable is required for EMC conformity and is recommended for all installations. The shield shall be grounded at the transmitter end only. If the shield is grounded at the switch, remote HLA I transmitter location, or remote DO supply the shield shall not be connected at the Wireless transmitter end.

Honeywell

A/A4

50036277

SCALE NONE

REV: E DATE 27 March 2012

SH. 6 of 11

**XYR 6000, MODEL CETW6000M-W WIRELESS CORROSION TRANSMITTER
 AND CETW6000M-D SmartCET CORROSION DATALOGGER**

Ex ia IIB; T4 Ta = 70°C; DIP A20 IP66 T90°C
 Ex nA [nL] IIC; T4 Ta = 84°C DIP A22 IP66 T90°C (≤ 80°C WITH OPTION DC)
 AMBIENT LIMITS: -30°C ≤ Ta ≤ 84°C (≤ 80°C WITH OPTION DC)

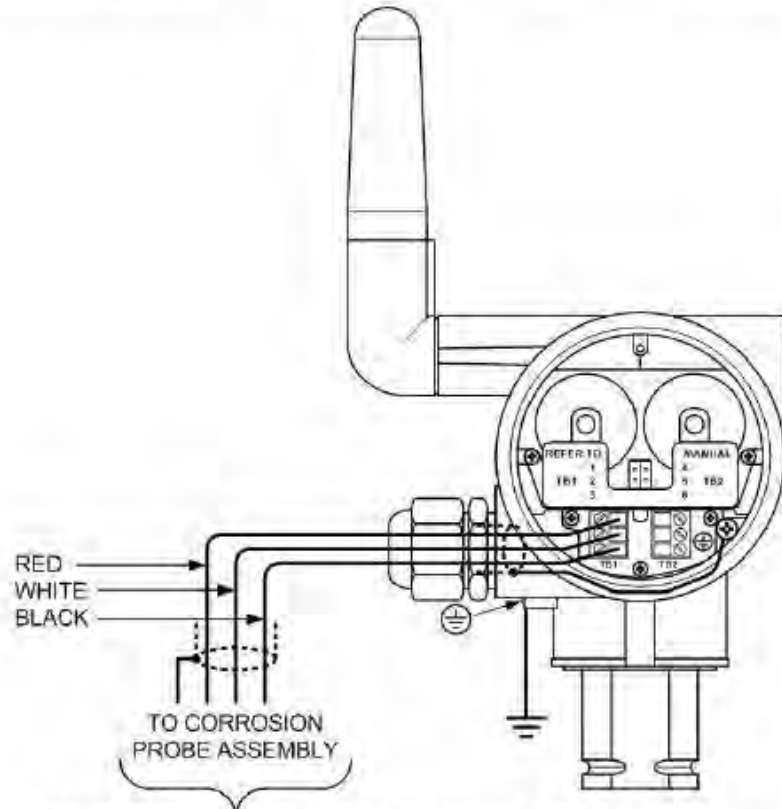

PROBE AND PROCESS ELECTRODES MUST BE PASSIVE ELEMENTS ONLY. PROBE AND CABLE PARAMETERS MUST NOT EXCEED $43 \mu\text{F} \geq C_{\text{PROBE}} + C_{\text{CABLE}}$ AND $0.25 \text{ mH} \geq L_{\text{PROBE}} + L_{\text{CABLE}}$

NOTE: The Probe connections are "ia" for connection to Zone 0 processes. The Probe used with the Corrosion Transmitter must be acceptable to the competent body having jurisdiction with respect to pressure and temperature ratings.

Honeywell	A/A4	50036277	
	SCALE NONE	REV: E DATE 27 March 2012	SH. 7 of 11

6. Certification Installation Requirements
 Certification Drawings

The following models may be supplied with internal battery power, or externally supplied 24Vdc only when connected to the MTL Associated Apparatus listed on the following system diagram.

NOTE: XYR 6000 ambient limits with 24V Power Supply are -40°C to +80°C.

Model	Description	
STGW944	Series 900 Wireless Transmitter, Dual Head Gage Pressure (GP)	0-500 psi / 0-35 bar
STGW974		0-3000 psi / 0-210 bar
STDW924	Series 900 Wireless Transmitter, Differential Pressure (DP)	0-400" H ₂ O / 0-1000 mbar
STDW930		0-100 psi / 0-7 bar
STDW974		0-3000 psi / 0-210 bar
STGW94L	Series 900 Wireless Transmitter, In-Line Gage & Absolute Pressure	0-500 psi / 0-35 bar
STGW97L		0-3000 psi / 0-210 bar
STGW98L		0-6000 psi / 0-415 bar
STGW99L		0-10,000 psig / 0-690 bar
STAW94L		0-500 psi / 0-35 barA
STFW924	Flanged Series 900 Wireless Pressure Transmitter	0- 400" H ₂ O/ 0- 1000 mbar Compound Characterized
STFW932		0- 100 psi/ 0- 7 bar Compound Characterized
STRW93D	Series 900 Wireless Transmitter, Dual Pressure & Gage Pressure Remote Seals	0- 2700" H ₂ O/ 0- 7 bar Compound Characterized
STRW94G		0- 500 psi/ 0- 35 bar
STFW92F	In-Line Flanged Series 900 Wireless Transmitter	0- 400" H ₂ O/ 0- 1000 mbar
STFW93F		0- 100 psi/ 0- 7 bar
STDW120	Series 100 Wireless Transmitter, Differential Pressure (DP)	0- 400" H ₂ O/ 0- 1000 mbar
STDW125		0- 600" H ₂ O/ 0- 1500 mbar
STDW130		0- 100 psi/ 0- 7 bar
STDW170		0- 3000 psi/ 0-210 bar
STGW14L		0- 500 psi/ 0- 35 bar
STGW17L	Series 100 Wireless Transmitter, In-Line Gage Pressure	0- 3000 psi/ 0- 210 bar
STGW18L		0- 6000 psi/ 0- 415 bar
STGW19L		0- 10000 psi/ 0- 690 bar
STAW14L	Series 100 Wireless Transmitter, In-Line Absolute Pressure	0- 500 psia/ 0- 35 barA
STAW140	Series 100 Wireless Transmitter, Single Head Absolute Pressure	0- 500 psia/ 0- 35 barA
STFW128	Flanged Series 100 Wireless Pressure Transmitter	0- 400" H ₂ O/ 0- 1000 mbar Compound Characterized
STFW132		0- 100 psi/ 0- 7 bar Compound Characterized
STFW12F		0- 400" H ₂ O/ 0- 1000 mbar
STFW13F		0- 100 psi/ 0- 7 bar
STFW14F		0- 600" H ₂ O/ 0- 1500 mbar
STRW12D	Series 100 Wireless Transmitter, Dual Pressure, Gage Pressure and Absolute Remote Seals	0- 400" H ₂ O/ 0- 1000 mbar Compound Characterized
STRW13D		0- 100 psi/ 0- 7 bar
STRW14A		0- 500 psia/ 0- 35 barA
STRW14G		0- 500 psi/ 0- 35 bar
STRW17G		0- 100 psi/ 0- 7 bar
STTW400	Wireless Temperature Transmitter	Transmitter Only with Remote Sensors: 3 T/C's, or 2 RTD's

Honeywell

A/A4

50036277

SCALE NONE

REV: E DATE 27 March 2012

SH. 8 of 11

Model	Description	
STTW401	Wireless Temperature and Digital Input Transmitter	Transmitter Only with Remote Sensors: 1 T/C AND 2 Digital Inputs
STXW500	Wireless Digital Input Transmitter	Three DI (Switch) Inputs
STUW700	Wireless Universal I/O Interface	Three Inputs: 4-20 mA Analog, T/C's, or DI (Switch)
STUW701	Wireless Universal I/O Interface	Two Inputs: 4-20 mA Analog, T/C or DI and One Digital Output (Solid State)
STTW820 STTW830 STTW840	Wireless Temperature Transmitter	Transmitter Integrally Mounted to Thermowell or Probe Assembly
STIW600	Wireless High Level Input Interface	4-20 mA Analog Input
CETW6000M-W	SmartCET Wireless Transmitter, Corrosion Monitoring	Millivolt Input from Remote Mounted Corrosion Probe
CETW6000M-D	SmartCET Corrosion Data Logger	Millivolt Input from Remote Mounted Corrosion Probe, Data via IrDA Port *

* There is no Antenna for this version

The above listed wireless transmitters may include an Omni-directional or unidirectional high-gain antenna. The high-gain antenna may be installed remote from the XYR 6000 with the cable length not to exceed 20m. The antenna cable shield shall be bonded to earth ground.

IS Entry parameters for remote antennas, cables & lightning arrestor:
Ca = 43 µF, La = 0.1 mH.

Honeywell	A/A4	50036277	
	SCALE NONE	REV: E DATE 27 March 2012	SH. 9 of 11

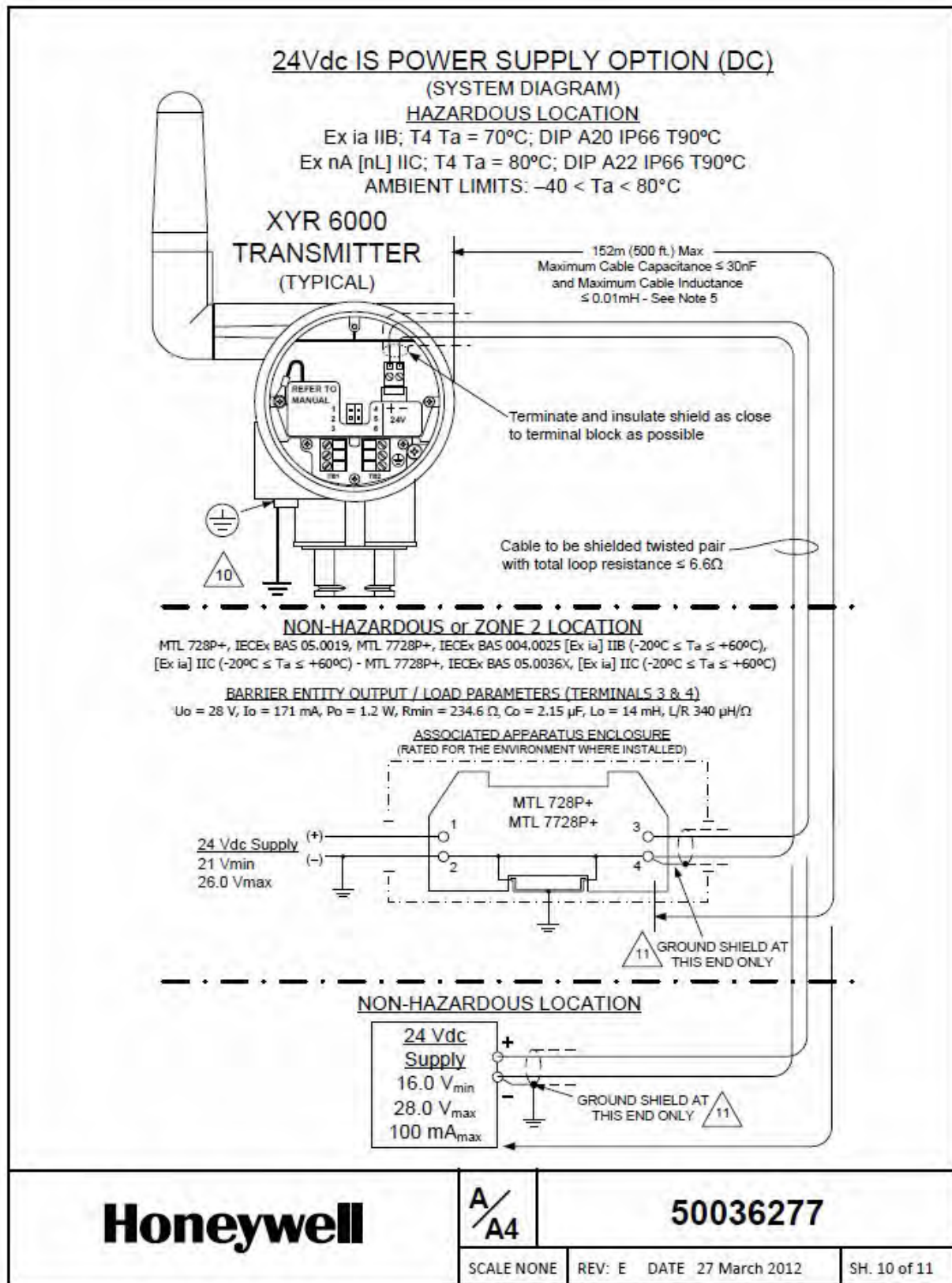

REMOTE ANTENNAS MUST BE
 PASSIVE ELEMENTS ONLY

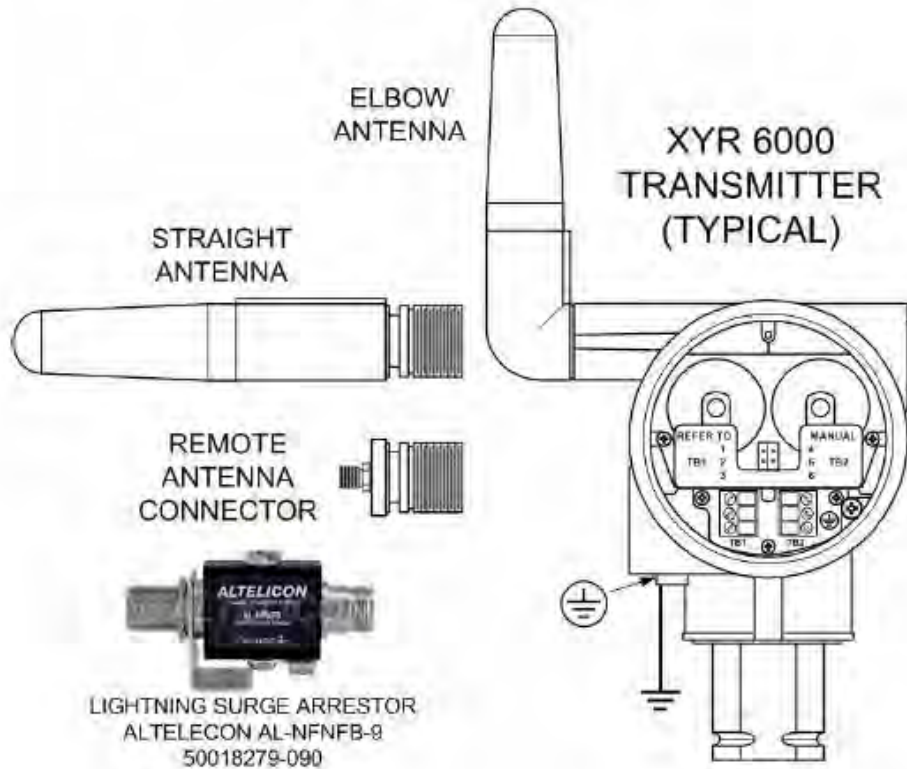

Honeywell	A/A4	50036277	
	SCALE NONE	REV: E	DATE 27 March 2012
			SH. 11 of 11

6. Certification Installation Requirements
 Certification Drawings

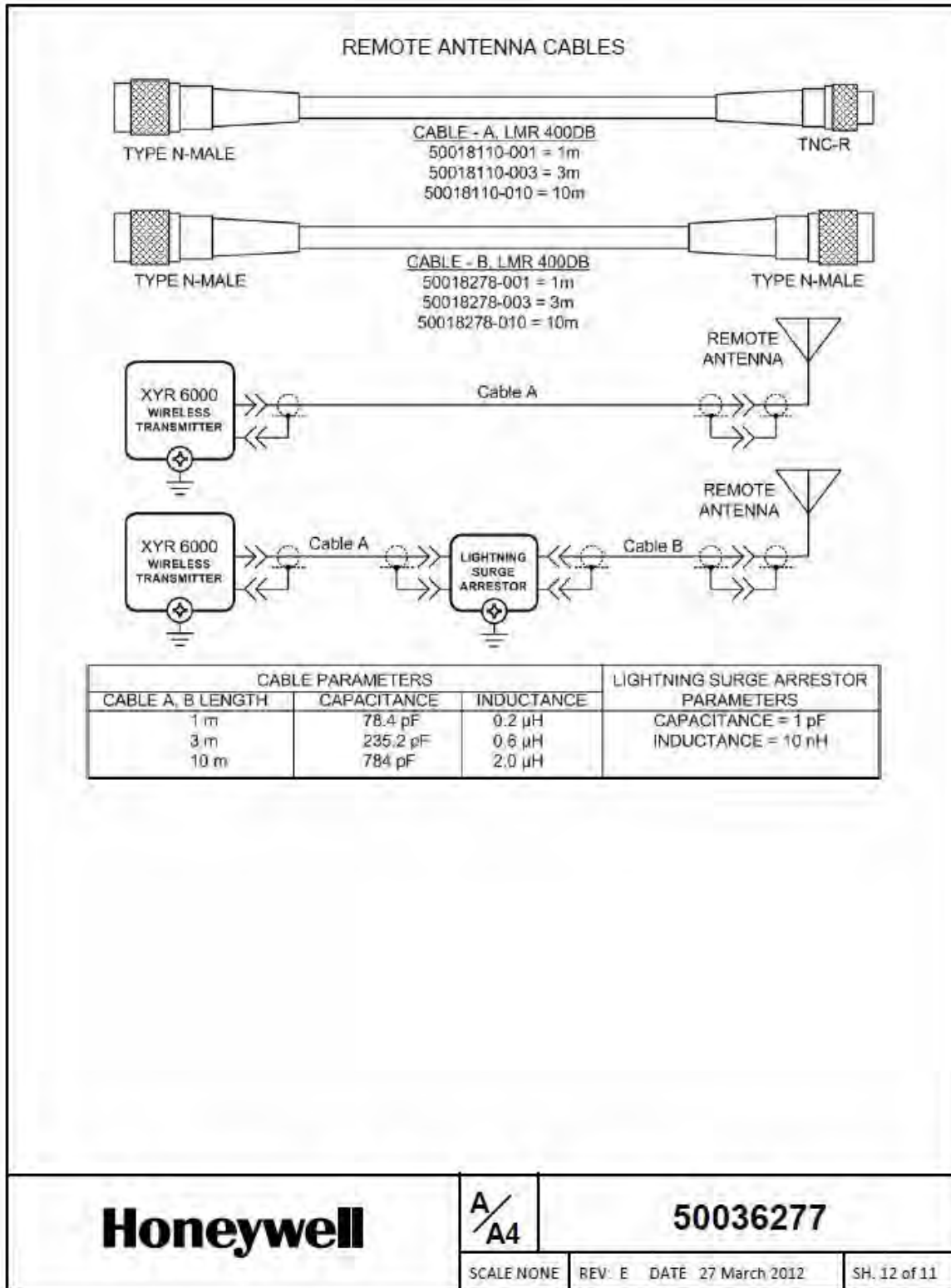

Honeywell

A/A4

50036277

SCALE NONE

REV: E DATE 27 March 2012

SH. 12 of 11

Sales and Service

For application assistance, current specifications, pricing, or name of the nearest Authorized Distributor, contact one of the offices below.

ASIA PACIFIC

(TAC)

hfs-tac-support@honeywell.com

Australia

Honeywell Limited
Phone: +(61) 7-3846 1255
FAX: +(61) 7-3840 6481
Toll Free 1300-36-39-36
Toll Free Fax:
1300-36-04-70

China – PRC - Shanghai

Honeywell China Inc.
Phone: (86-21) 5257-4568
Fax: (86-21) 6237-2826

Singapore

Honeywell Pte Ltd.
Phone: +(65) 6580 3278
Fax: +(65) 6445-3033

South Korea

Honeywell Korea Co Ltd
Phone: +(822) 799 6114
Fax: +(822) 792 9015

EMEA

Honeywell Process Solutions,
Phone: + 80012026455 or +44
(0)1202645583
FAX: +44 (0) 1344 655554

Email: (Sales)

sc-cp-apps-salespa62@honeywell.com

or

(TAC)

hfs-tac-support@honeywell.com

NORTH AMERICA

Honeywell Process Solutions,
Phone: 1-800-423-9883
Or 1-800-343-0228

Email: (Sales)

ask-ssc@honeywell.com

or

(TAC)

hfs-tac-support@honeywell.com

SOUTH AMERICA

Honeywell do Brasil & Cia
Phone: +(55-11) 7266-1900
FAX: +(55-11) 7266-1905

Email: (Sales)

ask-ssc@honeywell.com

or

(TAC)

hfs-tac-support@honeywell.com

Honeywell

Honeywell Process Solutions

1860 West Rose Garden Lane
Phoenix, Arizona 85027
www.honeywellprocess.com

34-XY-25-21 Revision 12
February 2013
©2013 Honeywell International Inc.