

Actuators IC 40

Technical Information · GB
3 Edition 07.18

- For complex applications with programmable functions for flexible adjustment to the process, with statistics and fault history to support service personnel
- Position indicator that can be read externally
- Spacious connection chamber for ease of installation
- Actuators can be delivered ready installed on butterfly valves BVG, BVGF, BVA, BVAF, BVH, BVHS or linear flow control VFC



Contents

Actuators IC 40	1
Contents	2
1 Application	4
1.1 Examples of application	6
1.1.1 Staged control	6
1.1.2 Staged control with three burner capacity levels	6
1.1.3 Continuous control by three-point step signal	7
1.1.4 Staged control with pre-purge	8
1.1.5 Continuous control with defined ignition position	9
1.1.6 Hot-air compensation	10
1.1.7 Staged control with online adjustment of the burner capacity	10
2 Certification	11
3 Function	12
3.1 Operating modes	13
3.2 Standard and analogue operating modes	13
3.3 Closed, low-fire rate, intermediate and open position	13
3.4 Running times	14
3.5 Standard operating modes 1 – 12	15
3.5.1 2-point operation	15
3.5.2 2-point operation with flame proving period	16
3.5.3 2-stage operation with one or two digital inputs	17
3.5.4 2-stage operation with two digital inputs	19
3.5.5 3-point step operation	20
3.5.6 3-stage operation with one or two digital inputs	21
3.5.7 2-point operation with switchover of the adjustment angle for the “open” position	23
3.5.8 2-point operation with input-dependent adjustment angle for the “open” position	25
3.5.9 2-point operation with switchover of the running times	26
3.5.10 3-point step operation with running time fractions	27
3.5.11 3-stage operation with two digital inputs	29
3.5.12 3-point step operation with low position	30

3.6 Analogue operating modes 21 – 27	31
3.6.1 2-point operation	31
3.6.2 2-point operation with switchover of the adjustment angle for the “open” position	33
3.6.3 2-point operation with input-dependent adjustment angle for the “open” position	35
3.6.4 2-point operation with switchover of the running times	36
3.6.5 2-point operation with characteristic curve switchover I	38
3.6.6 2-point operation with characteristic curve switchover II	40
3.6.7 2-stage operation with two digital inputs and variable adjustment angle for the “open” position	42
3.6.8 Emergency closing function	43
3.7 Parameters	44
3.7.1 Parameter sets	45
3.7.2 Factory default parameters	47
3.8 Inputs	48
3.8.1 Digital	48
3.8.2 Analogue	48
3.9 Outputs	50
3.10 Manual mode	51
3.10.1 Direct position preset	51
3.10.2 Simulate inputs	51
3.11 Statistics	52
3.11.1 Counters	52
3.11.2 Measured values	52
3.11.3 Resetting statistics	52
3.11.4 Resetting a signal	52
3.12 Connection diagram	53
3.13 Display	54
3.13.1 During operation	54
3.13.2 Warnings and faults	54
3.14 Relay outputs RO 1 and RO 2 function	56

4 Replacement possibilities for actuators	57
4.1 GT 31 is to be replaced with IC 40	57
4.2 M 5/M 6 is to be replaced with IC 40	58
5 Selection	59
5.1 Selection table	59
5.2 Type code	59
6 Project planning information	60
6.1 Electrical connection	60
6.1.1 Cable selection	60
6.1.2 Digital inputs	60
6.1.3 Feedback signalling	61
6.2 Feedback potentiometer	62
6.3 Installation	62
6.4 Commissioning	63
7 Accessories	64
7.1 Heat deflectors	64
7.2 “Single application” attachment set	64
7.3 BCSoft	65
7.3.1 Opto-adapter PCO 200	65
7.4 Cable gland with pressure equalization element	65
8 Technical data	66
8.1 Running times and torques	67
8.2 Dimensions	68
8.2.1 IC 40	68
9 Maintenance cycles	69
10 Glossary	70
10.1 Start fuel flow rate	70
10.2 Positions	70
10.3 Adjustment angle for the “open” position	70
11 Legend	71
Feedback	72
Contact	72

1 Application

Actuator IC 40 is designed for all applications that require precise, controlled rotary movement between 0° and 90°. It can be mounted directly onto the butterfly valves BVG, BVGF, BVA, BVAF, BVH, BVHS or linear flow control VFC in order to control the gas and air flow rates on gas burners.

Actuators and butterfly valves or linear flow control VFC can also be delivered ready assembled as butterfly valves with actuator IBG, IBGF, IBA, IBAF, IBH, IBHS or linear flow control IFC, see Technical Information Butterfly valves BVG, BVA, BVH..., IB..., and Linear flow controls VFC, IFC.

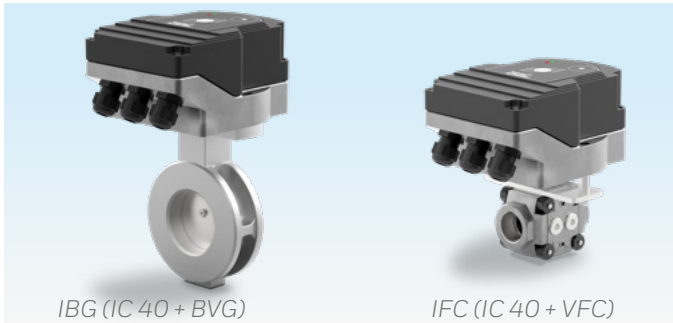

An optional integrated feedback potentiometer offers the option of monitoring the current position of the actuator. This checking function can be used in automation processes.



The IC 40 can be used on continuously-controlled burners and on stage-controlled burners.

Settings on the actuator IC 40 can be made using a PC with the programming software BCSoft. All the relevant settings for the process are made using the software via an optical interface. Various operating modes, which may be modified, are stored in the unit. In addition, the control type (two-point step signal, three-point step signal or continuous control), running times, adjustment angles and intermediate positions can be programmed.

The actuator can also be controlled “by hand” using the software.

Once set, all the parameters can be saved on the PC and copied from there into other actuators, thus saving time during the commissioning process.

Service technicians can call up statistical data using BCSoft, such as hours of operation, actuating cycles and a fault history. Some values can also be set to zero, for example to record data over a specific period of time.



Roller hearth kiln in the ceramics industry



Forging furnace

1.1 Examples of application

1.1.1 Staged control

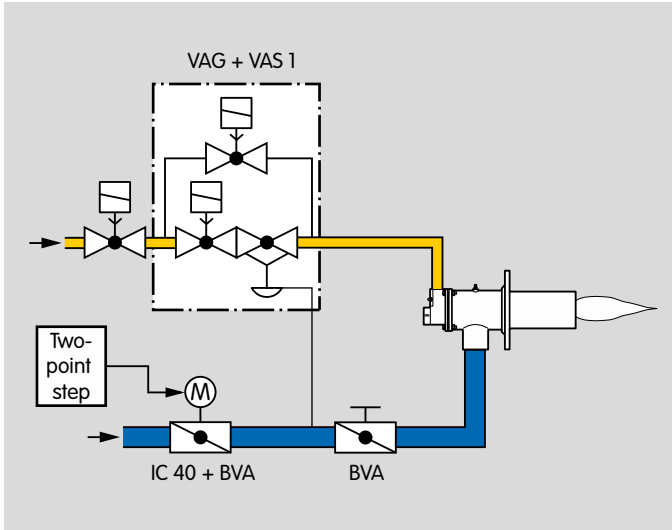

For processes that require a homogeneous temperature distribution in the furnace. The actuator IC 40 is controlled by a two-point controller and operates in On/Off or High/Low intermittent mode. The actuator closes when the voltage supply is interrupted. The running time can be infinitely adjusted between 5 and 25 seconds.

1.1.2 Staged control with three burner capacity levels

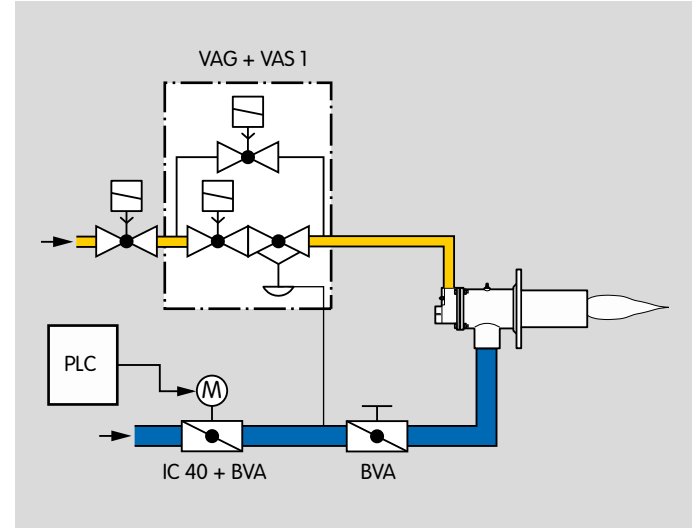

For processes that require a homogeneous temperature distribution in the furnace and three burner capacity levels. The actuator IC 40 is controlled by a programmable logic controller and works in High/Medium/Low or High/Medium/Low/Off intermittent mode. This allows the ignition stage to be started. The optional pressure switch provides fail-safe monitoring of the maximum pilot air volume. The actuator running time can be infinitely adjusted between 5 and 50 (75) seconds.

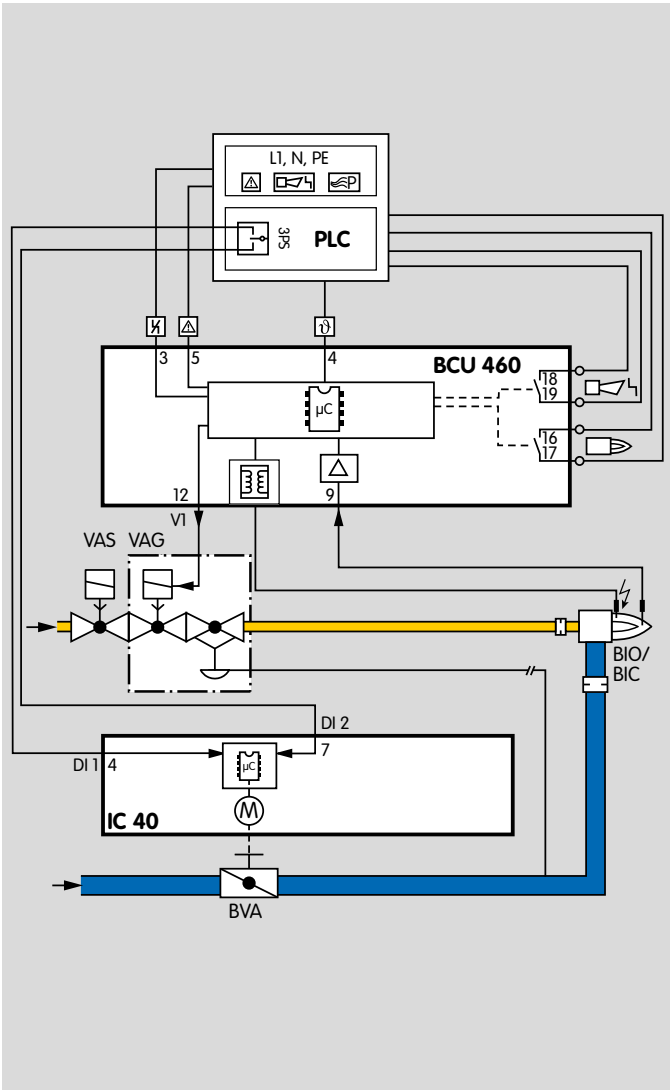

1.1.3 Continuous control by three-point step signal

The actuator IC 40 is controlled by the three-point step controller 3PS and moves the butterfly valve BVA to the ignition position. The burner starts.

Once the burner is operating, the operation signalling contact of the burner control unit BCU 460 closes. The BCU issues the controller enable signal to the temperature controller. The butterfly valve opens or closes between the low-fire and high-fire rate positions depending on the capacity demand of the burner. When the three-point step signal is disconnected, the butterfly valve stops at its current position.

If both inputs on the IC 40 (DI 1 and DI 2) are activated after the burner has been shut down, the butterfly valve closes further than the low-fire rate position (see Operating mode 12, 3-point step operation with low position).

DI 1	DI 2	IC 40 position	Valve position
Off	Off	Idle/Stop	Idle
On	Off	Open to high position	Open to high-fire rate
Off	On	Close to middle position	Close to low-fire rate
On	On	low	Valve closes further

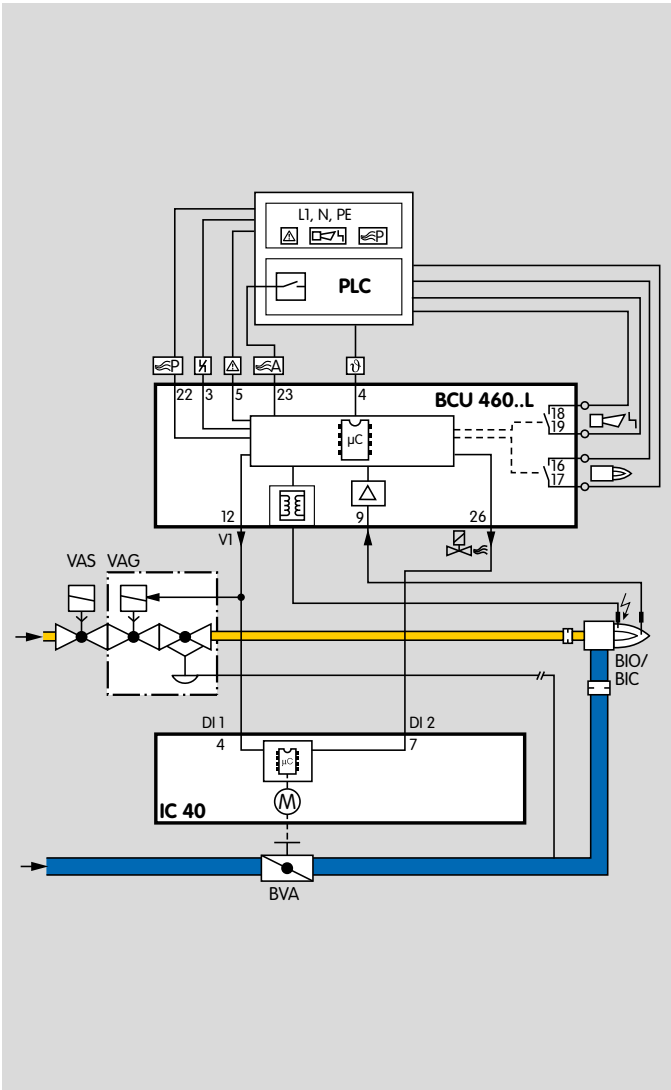

1.1.4 Staged control with pre-purge

The central control system starts the pre-purge. Input DI 2 is activated via the air valve output of the BCU and the butterfly valve BVA is set to the pre-purge position.

In the event of a temperature demand, the burner control unit BCU activates input DI 1 via the valve output V1 and moves the butterfly valve to the ignition position (precondition: the IC 40 must have reached the ignition position on the instant of ignition). The burner starts.

To activate the high-fire rate, DI 2 is actuated via the air valve output on terminal 26 of the BCU.

The butterfly valve moves cyclically between the high-fire rate position and the low-fire rate position (see Operating mode 11, 2-stage operation with two digital inputs).

DI 1/V1	DI 2/air valve	IC 4 position	Valve position
Off	Off	closed	Closed
On	Off	low	Ignition position/low-fire rate
On	On	middle	High-fire rate
Off	On	high	Pre-purge

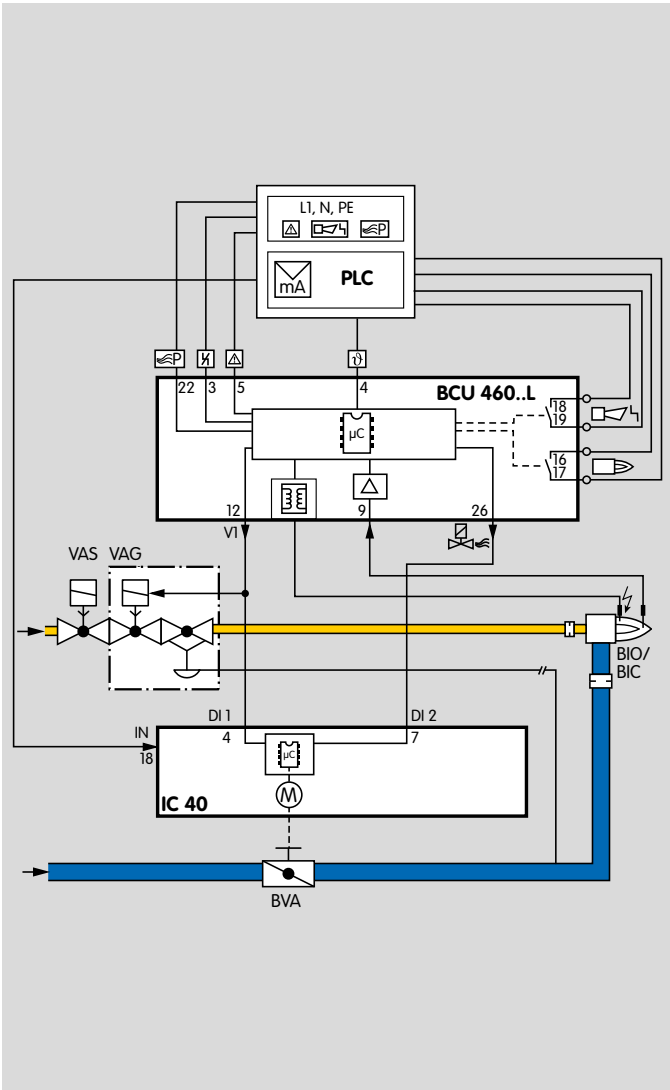

1.1.5 Continuous control with defined ignition position

The central control system starts the pre-purge. Input DI 2 is activated via the air valve output of the BCU and the butterfly valve BVA is set to the pre-purge position.

In the event of a temperature demand, the burner control unit BCU activates input DI 1 via the valve output V1 and moves the butterfly valve to the ignition position (precondition: the IC 40 must have reached the ignition position on the instant of ignition). The burner starts.

The BCU activates DI 2 via the air valve output. This enables the analogue input IN on the actuator IC 40. Depending on the capacity demand of the temperature controller, the butterfly valve BVA moves steplessly to the position between the low-fire rate and the high-fire rate as specified by the analogue input IN (see Operating mode 27, 2-stage operation with two digital inputs and variable adjustment angle for the open position).

DI 1/V1	DI 2/air valve	IC 40 position	Valve position
Off	Off	closed	Closed
On	Off	low	Ignition position/low-fire rate
On	On	analogue chart 1	In acc. with chart 1
Off	On	high	Pre-purge/high-fire rate

1.1.6 Hot-air compensation

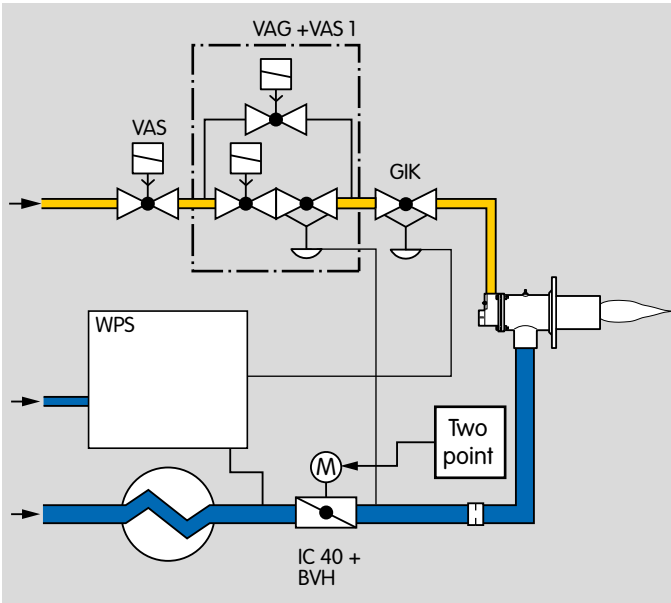

For processes in which preheated combustion air at a temperature of up to 450°C must be controlled. In this example, the actuator IC 40 is controlled by a two-point controller to adjust the burner capacity. It runs in High/Low intermittent mode. The running time can be adjusted between 5 and 25 seconds.

1.1.7 Staged control with online adjustment of the burner capacity

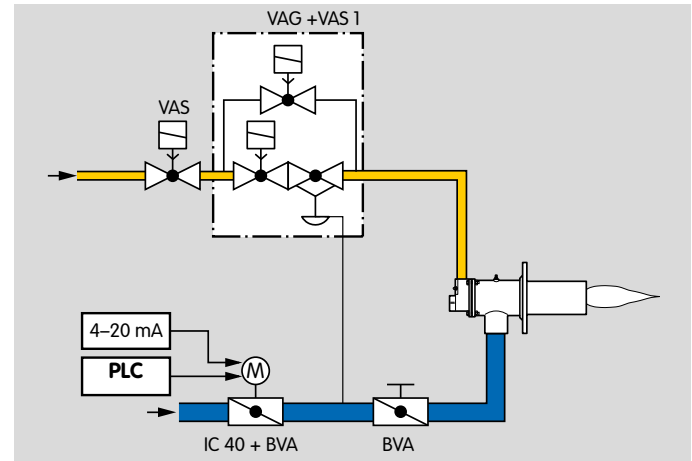

For processes that require a homogeneous temperature distribution and high temperature accuracy in the furnace.

If only a low heat output is required, for example to maintain the temperature in the furnace, the burner can continue to be operated in intermittent mode. The adjustment angle of the valve is reduced via the analogue input (4 – 20 mA) of the actuator and the burner capacity is therefore lowered. This ensures uniform temperature distribution even with a low heat output.

This function of the actuator IC 40 can also be used in the ceramics industry to correct the lambda value or for temperature compensation purposes in hot-air applications.

2 Certification

Certificates – see Docuthek.

EU certified



Meets the requirements of the

- Low Voltage Directive (2014/35/EU)
- EMC Directive (2014/30/EU)

Standards:

- EN 60730-2-14

Eurasian Customs Union



The product IC 40 meets the technical specifications of the Eurasian Customs Union.

ANSI/CSA approved



American National Standards Institute/Canadian Standards Association – ANSI/UL 429 and CSA C22.2. Class number: C322102, Class number: C322182 www.csagroup.org.

Directive on the restriction of the use of hazardous substances (RoHS) in China

Scan of the Disclosure Table China RoHS2 – see certificates at www.docuthek.com

UL listed



Underwriters Laboratories – UL 60730-1 “Automatic Electrical Controls for Household and Similar Use”, UL 60730-2-14 “Automatic Electrical Controls for Household and Similar Use; Part 2: Particular Requirements for Electric Actuators”, File No. E4436.

3 Function

The actuator IC 40 moves the butterfly valve towards 0° or 90°. There are 4 possible positions which the actuator can approach in steps. Any intermediate position is possible in continuous three-point step mode. Optionally, the actuator can also approach any intermediate position via an additional current input.

The slow flashing blue LED indicates that the motor of actuator IC 40 is moving. The position indicator on the housing indicates the opening angle. Further visualization and operation are performed on a PC using the BCSOft software.

BCSOft

The sequence of opening and closing is programmed using the BCSOft software and can be adapted individually to any application.

All settings for the actuator IC 40 are made using BCSOft. Commissioning and calibration of the “closed” position are performed conveniently using the software.

BCSOft offers the option of moving and adjusting the butterfly valve in Manual mode via the actuator, see page 51 (Manual mode).

A detailed manual is available for the BCSOft PC software:

www.docuthek.com ► Home ► Elster Thermal Solutions ► Products ► O3 Valves and butterfly valves ► Actuators IC ► BCSOft (D, GB)

3.1 Operating modes

The operating mode is responsible for the setting properties of the IC 40.

The running times and dwell positions of the actuator are stored in the various operating modes but can be reprogrammed at any time using BCSoft (if mounted on butterfly valve BV..).

The actuator operates in continuous and intermittent mode with various adjustment angles for the “open” position. The adjustment angles for the “open” position indicate the approached position of the actuator in the case of intermittent operation. They can be changed in BCSoft.

The corresponding operating modes are displayed in BCSoft as flowcharts by way of example to visualize the opening/closing behaviour of the actuator.

3.2 Standard and analogue operating modes

In the **standard operating modes**, two digital inputs (DI 1 and DI 2) of the actuator are pre-assigned at the works as universal inputs. If a voltage of 24 V DC or 100 – 230 V AC is applied to the input, this is recognized as “On” signal (positive logic). It is not necessary to set or readjust the voltage magnitude or voltage type.

In the **analogue operating modes**, an additional input (IN) is assigned for the actuator. If an actuator IC 40..A with 4 – 20 mA analogue input is connected (option), further operating modes are available in addition to the

standard operating modes. The actuator can approach corresponding intermediate positions via a current signal to the additional input, see page 49 (Priority and running time in operating modes 1 – 10).

3.3 Closed, low-fire rate, intermediate and open position

Depending on the set operating mode, there are 4 positions which the actuator can approach:

Closed = $0^\circ = 0\%$,

Low = low-fire rate position,

Middle = intermediate position,

High = open position.

The positions not used by the operating mode are barred.

The “closed position” is always the calibrated zero position of the device and cannot be readjusted. The other positions can be defined on site.

Basically, the following parameter limits must be noted.

Ascending sequence of positions:

0% = closed →

low →

middle →

high ≤ 100%

The “high position” must not be selected less than 10 %.

If the positions have been changed in the software, BCSofT checks the new values for compliance with the limits and adapts the positions.

3.4 Running times

Up to 6 running times (t_1 to t_6), each between 0 and max. 25.5 seconds, can be set dependent on the operating mode.

A minimum running time is required for each change in position.

Minimum actuator running time t_{\min} :

$$t_{\min} = \frac{4.5 \text{ s} \times \text{change in position}\%}{100\%}$$

Times which are too short are automatically corrected by the IC 40 to the minimum possible value. If the actuator is to operate as fast as possible, a time of 0 seconds can be preset.

In the case of position changes < 16.2%, the maximum running time is reduced from 25.5 s percentage-wise.

The IC 40 corrects the time to the maximum possible value.

After they have been entered, the valid parameters are automatically read out and displayed in BCSofT.

We recommend switching to Manual mode when commissioning in order to establish the right positions and running times for the application, see page 51 (Manual mode).

Outputs

In addition to feedback signals, it is also possible to assign freely adjustable position ranges to the two outputs, RO 1 and RO 2, see page 50 (Outputs).

Statistics

The statistical data stored in the unit, such as faults which have occurred, various counter readings and measured values, are displayed and read out in BCSofT, see page 52 (Statistics).

Emergency closing function

A pre-tensioned spiral spring moves the drive shaft with valve disc to the closed position in the event of faults or if the continuous supply voltage is interrupted, within the closing time < 1 s, see page 43 (Emergency closing function).

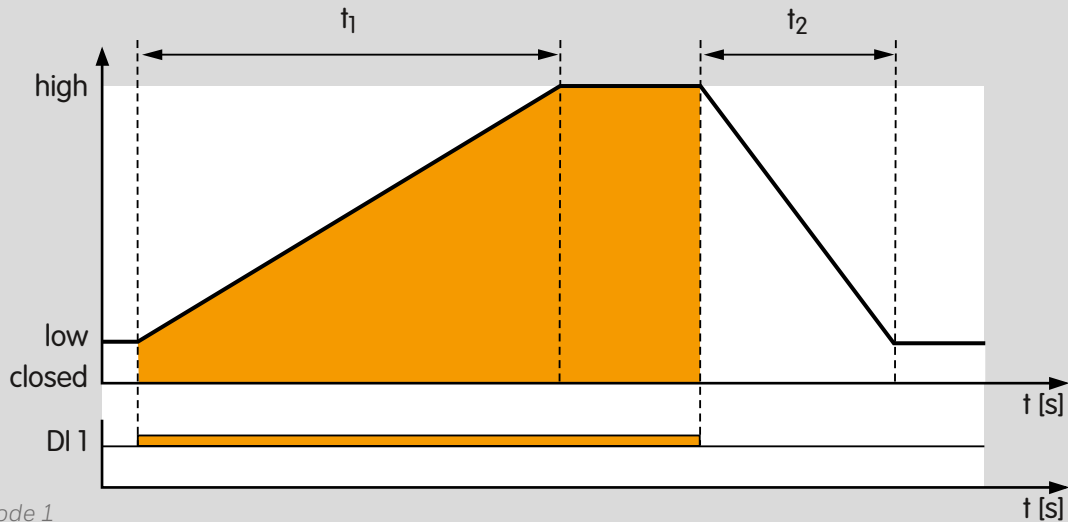

Operating mode 1

3.5 Standard operating modes 1 – 12

General description, see page 13 (Operating modes).

3.5.1 2-point operation

Operating mode 1

In idle state (DI 1 with no signal), the actuator is in “low” position (“low” position may also be 0° = “closed” position).

If a signal is applied to digital input DI 1, the actuator moves to “high” position within running time t_1 . When the signal at digital input DI 1 drops, the actuator moves back to “low” position within running time t_2 .

DI 1	Position
Off	low/closed
On	high

If the signal at digital input DI 1 is deactivated before “high” position is reached, the actuator moves directly to “low” position within the percentage time of t_2 .

The actuator operates in high/low (high/closed) intermittent mode.

Possible parameter sets for this operating mode: P68017, P68018 and P68019, see page 45 (Parameter sets).

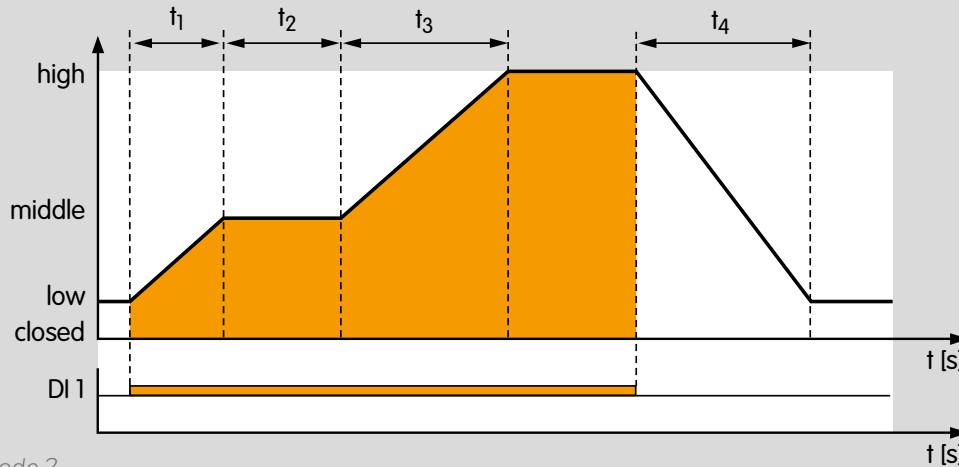

Operating mode 2

3.5.2 2-point operation with flame proving period

Operating mode 2

In idle state (DI 1 with no signal), the actuator is in “low” position (“low” position may also be 0° = “closed” position).

If digital input DI 1 is activated, the actuator moves to “middle” position within running time t_1 .

After waiting time t_2 , the actuator automatically moves further to “high” position within running time t_3 .

As the voltage at digital input DI 1 drops, the actuator closes to “low” position within running time t_4 .

DI 1	Position
Off	low/closed
On	high

If the signal at digital input DI 1 is deactivated before “high” position is reached, the actuator moves directly to “low” position within the percentage time of t_4 .

The actuator operates in high/middle/low (high/middle/closed) intermittent mode.

On burners which must ignite during opening of the butterfly valve, waiting time t_2 is appropriate for flame proving.

Possible parameter set for this operating mode: P 68021, see page 45 (Parameter sets).

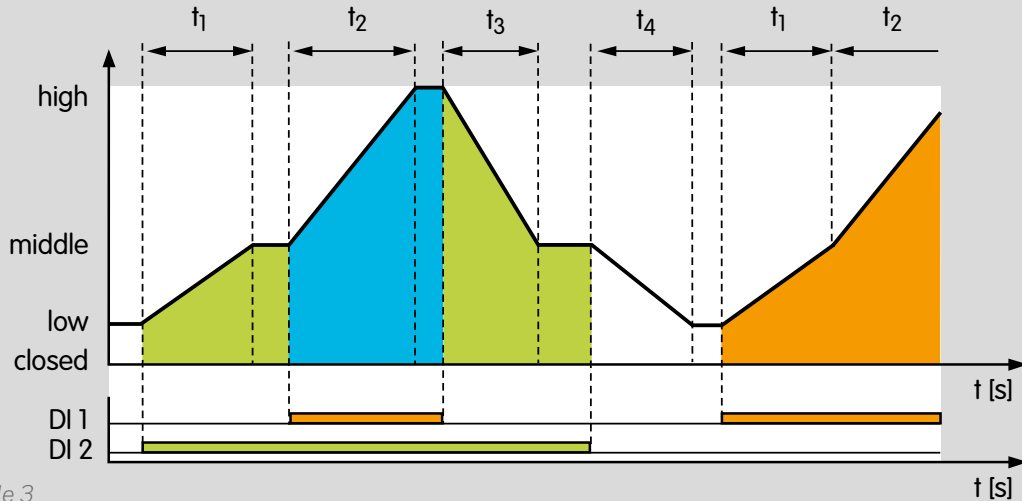

Operating mode 3

3.5.3 2-stage operation with one or two digital inputs

Operating mode 3

In idle state (DI 1 and DI 2 with no signal), the actuator is in "low" position ("low" position may also be 0° = "closed" position).

Control via two digital inputs

If digital input DI 2 is activated, the actuator moves from "low" position to "middle" position within running time t_1 .

If, in addition, digital input DI 1 is activated, the actuator approaches "high" position within running time t_2 .

When the signal at DI 1 drops, the actuator moves back to "middle" position within running time t_3 and closes the control element to "low" position within running

time t_4 if the signal is also disconnected from DI 1. The actuator operates in high/middle/low (high/middle/closed) intermittent mode.

DI 1	DI 2	Position
Off	Off	low/closed
On	Off	high (DI 1 has priority)
Off	On	middle
On	On	high

In this operating mode, digital input DI 1 has priority and its signal always leads to opening of the actuator to "high" position.

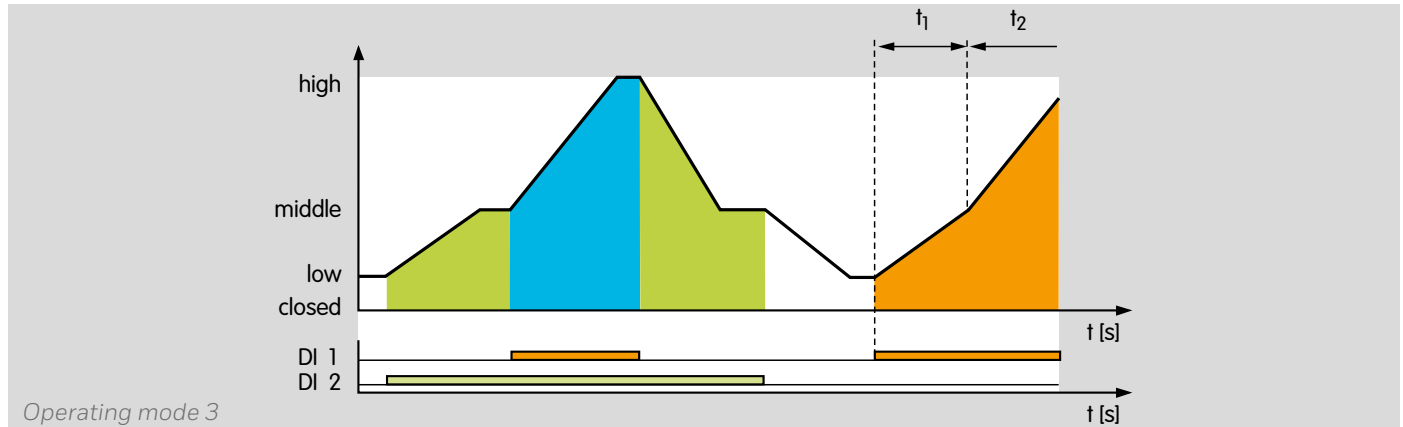

This may prove to be practical in order to purge a furnace or kiln via DI 1 (independently of DI 2), for instance. It is then possible to operate with both inputs in high/middle/low intermittent mode.

Possible parameter sets for this operating mode: P 68015, P68016, see page.45 (Parameter sets).

Control via one digital input

If digital input DI 1 is activated (DI 2 with no signal), the actuator moves to “high” position. The running times t_1 and t_2 run directly in succession.

Likewise, the actuator closes within the successive running times t_3 and t_4 if signal DI 1 drops. The “middle” position serves as an interpolation point and can be freely programmed.

Owing to the two successive running times, the opening characteristic of the butterfly valve can be changed. For example, the characteristic of the air circuit can be adapted to that of the gas circuit.

Running times up to 51 s (2 x 25.5 s) are possible in this operating mode. If the signal at digital input DI 1 is deactivated before “high” position is reached, the actuator moves directly to “low” position within the percentage times of t_3 and t_4 .

The actuator operates in high/low (high/closed) intermittent mode.

DI 1	DI 2	Position
Off	Off	low/closed
On	Off	high

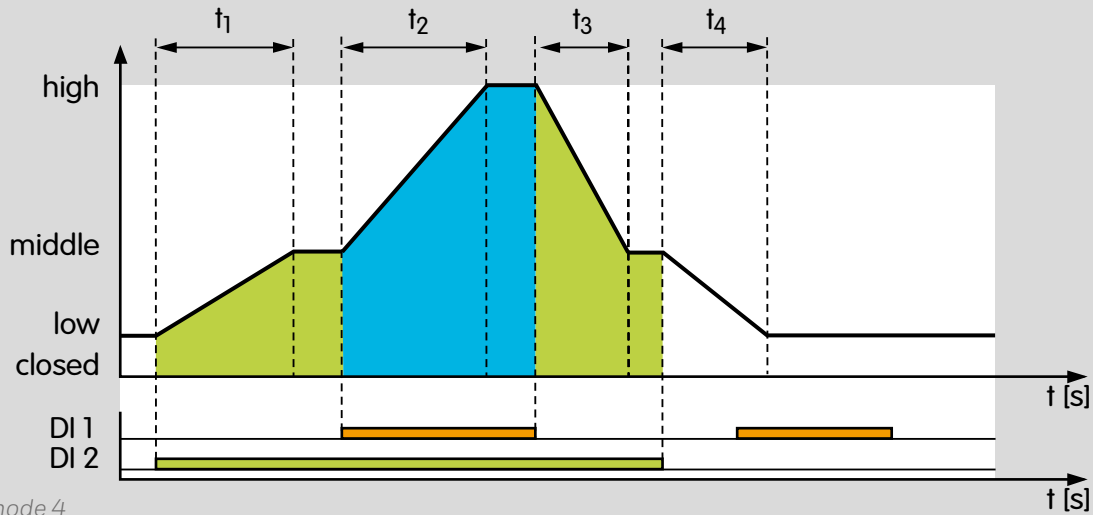

Operating mode 4

3.5.4 2-stage operation with two digital inputs

Operating mode 4

The function corresponds to operating mode 3 with different priority of the digital inputs.

Digital input DI 2 has priority over DI 1. This means that a signal at DI 1 has no effect unless a signal is also applied to DI 2.

DI 1	DI 2	Position
Off	Off	low/closed
On	Off	low/closed (DI 2 has priority)
Off	On	middle
On	On	high

Possible parameter set for this operating mode: P 68022, see page 45 (Parameter sets).

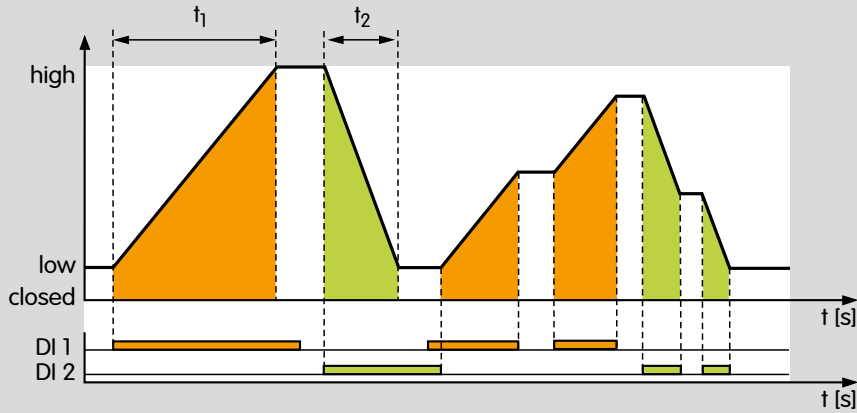

Operating mode 5

3.5.5 3-point step operation

Operating mode 5

If only digital input DI 1 is active, the actuator opens. If only digital input DI 2 is active, the actuator closes.

If neither of the digital inputs or both digital inputs are active simultaneously, the actuator stops in its position. This means that it can be stopped in any position.

The actuator operates in continuous mode and is controlled via a 3-point step signal. The setting function is limited by the “low” and “high” positions (“low” position may also be 0° = “closed” position).

The opening speed is preset via the time t_1 for the entire “low” to “high” setting travel. Accordingly, the closing speed is set with t_2 for the entire “high” to “low” setting travel.

Possible parameter sets for this operating mode: P68012, P68013, P68014, see page 45 (Parameter sets).

DI 1	DI 2	Reaction
Off	Off	Idle/Stop
On	Off	Open to “high” position at max.
Off	On	Close to “low” position (“closed” position) at min.
On	On	Idle/Stop

This method of control is frequently used on furnaces and kilns in the sector of ceramics, steel and aluminium.

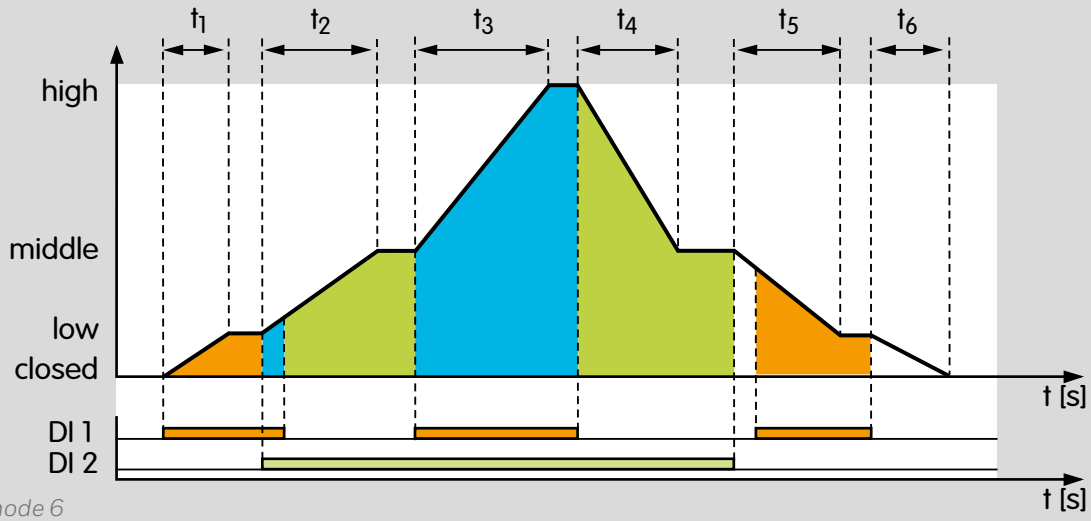

Operating mode 6

3.5.6 3-stage operation with one or two digital inputs

Operating mode 6

Each of the 4 circuit combinations resulting from DI 1 and DI 2 determines precisely one actuator position:

DI 1	DI 2	Position
Off	Off	closed
On	Off	low
Off	On	middle
On	On	high

Each signal change results in a new position setpoint for the actuator. If the signals overlap (see t_2), the actuator moves towards “high”. If the signals do not overlap (see t_5), the actuator moves towards “closed”.

Various modes of operation can be implemented with this operating mode.

Control via one digital input

DI 2 with no signal:

The actuator operates in low/closed intermittent mode via digital input DI 1.

DI 1 with no signal:

The actuator operates in middle/low intermittent mode via digital input DI 2.

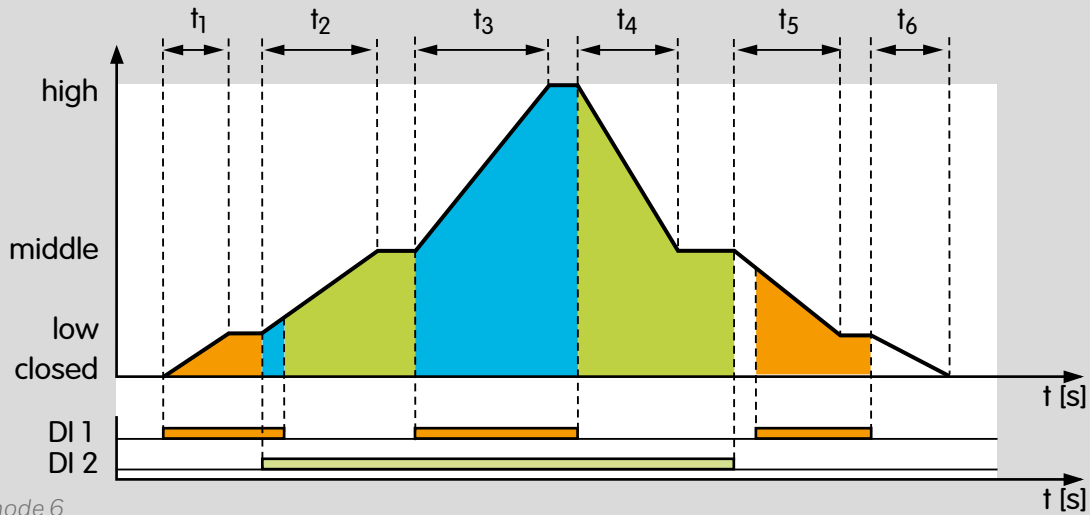

DI 1 with continuous signal, for instance resulting from inversion of the logic, see page 48 (Switching logic):

The actuator operates in high/low (high/closed) intermittent mode via digital input DI 2 with two successive running times up to 51 s (2 x 25.5 s).

DI 1 and DI 2 are connected in parallel:

The actuator operates with one signal in high/closed intermittent mode with three successive running times up to 76.5 s (3 x 25.5 s).

With three successive running times via interpolation points, it is possible to change the opening characteristic of the butterfly valve. For example, the characteristic of the air circuit can be adapted to that of the gas circuit.

Control via two digital inputs

If all possible combinations of the two inputs are used, for instance by a PLC control system, it is possible to implement high/middle/low/closed intermittent mode (3 stages plus the “closed” position).

Possible parameter set for this operating mode: P 68001, see page 45 (Parameter sets).

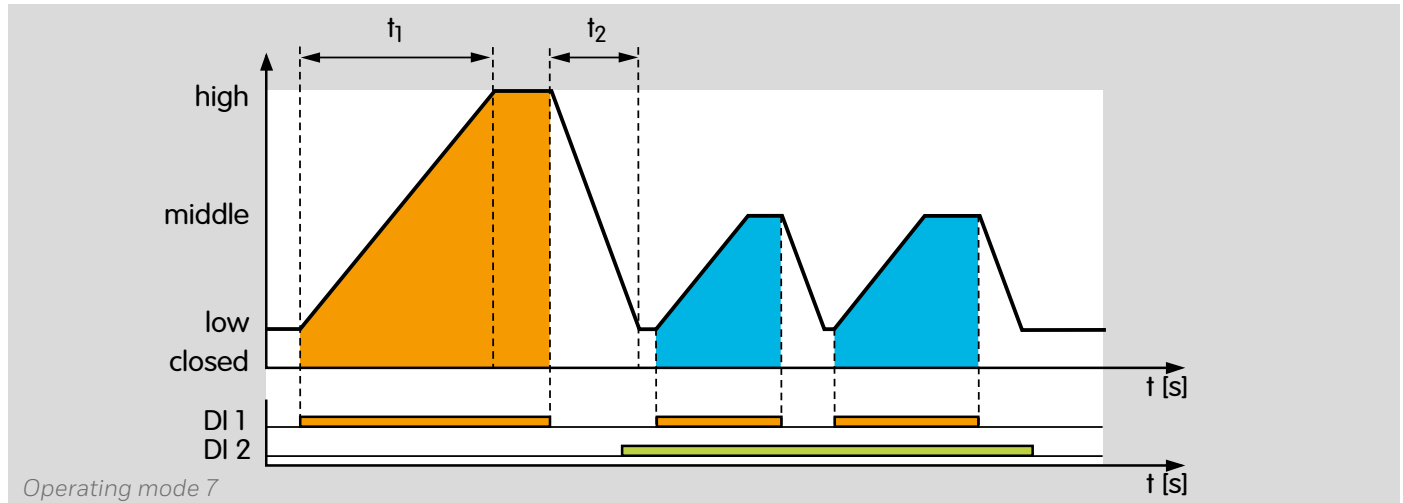

3.5.7 2-point operation with switchover of the adjustment angle for the “open” position

Operating mode 7

In idle state (DI 1 and DI 2 with no signal), the actuator is in “low” position (“low” position may also be 0° = “closed” position).

Digital input DI 1 functions as a pulse input.

DI 2 has no signal:

The actuator operates in high/low (high/closed) intermittent mode via digital input DI 1.

Signal at DI 2:

The actuator can switch over its intermittent mode between high/low (high/closed) and middle/low (middle/closed) during ongoing operation.

The adjustment angle for the “open” position is then approached with signal at DI 1 and switched over via DI 2.

The actuator now operates in middle/low (middle/closed) intermittent mode via digital input DI 1.

The heat output can now be reduced and it is nevertheless possible to continue operation in intermittent mode so as to ensure a uniform temperature distribution. High/low may also be used for purging and middle/low may also be used for heating mode in order to reduce the pre-purge time, for instance.

DI 1	DI 2	Position
Off	Off	low/closed
On	Off	high
Off	On	low/closed (DI 1 has priority)
On	On	middle

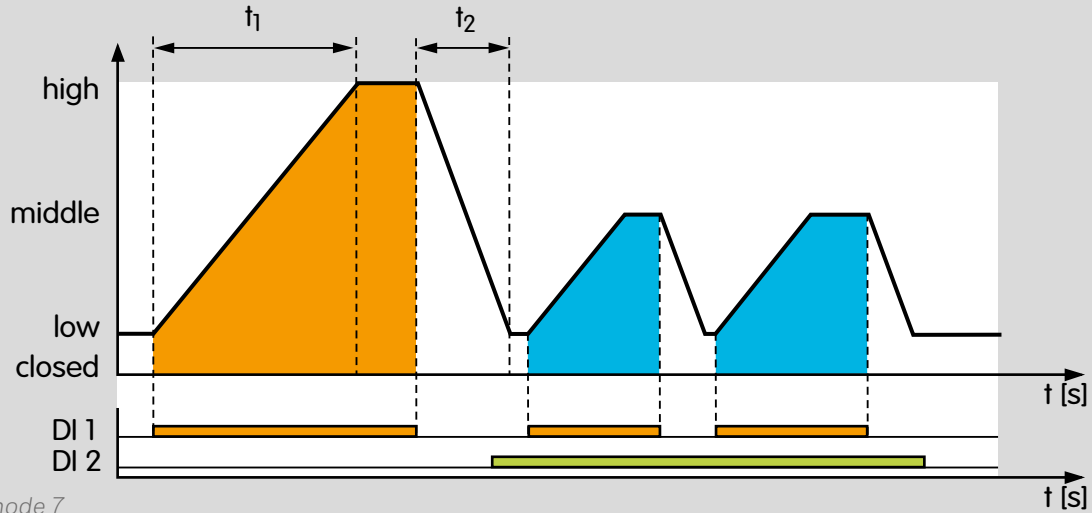

Operating mode 7

The opening speed is preset via the running time t_1 for the entire “low” to “high” setting travel. Accordingly, the closing speed is set with t_2 for the entire “high” to “low” setting travel. The speeds are retained when switching with reduced capacity (signal at DI 2). The running time is shortened in accordance with the reduced position.

Alternative function (2-stage operation with constant speed):

DI 1	DI 2	Position
Off	Off	low/closed
On	Off	high
Off	On	low/closed (DI 1 has priority)
On	On	middle

For as long as a signal is applied to DI 1, DI 2 switches to and fro between “high” and “middle” position. In this case, it may be practical to invert the logic of digital input DI 2, see page 48 (Switching logic).

This mode of operation ensures that the actuator always opens or closes at constant speed.

Possible parameter set for this operating mode: P 68023, see page 45 (Parameter sets).

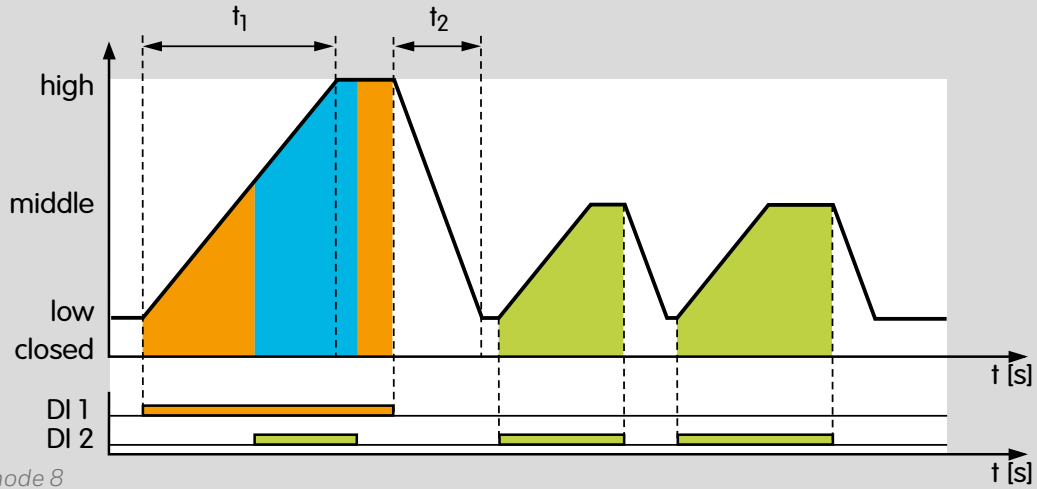

Operating mode 8

3.5.8 2-point operation with input-dependent adjustment angle for the “open” position

Operating mode 8

The function corresponds to operating mode 7 apart from the fact that both digital inputs function as pulse inputs.

The actuator operates in high/low (high/closed) intermittent mode via digital input DI 1 and operates in middle/low (middle/closed) mode via DI 2.

A signal at DI 1 (priority) always leads to approaching “high” position which can be used to purge the furnace or kiln, for instance.

DI 1	DI 2	Position
Off	Off	low/closed
On	Off	high
Off	On	middle
On	On	high (DI 1 has priority)

Alternative function: 2-stage operation with constant speed.

For as long as a signal is applied to DI 2, DI 1 switches to and fro between “high” and “middle” position.

This mode of operation ensures that the actuator always opens or closes at constant speed.

Possible parameter set for this operating mode: P68024, see page 45 (Parameter sets).

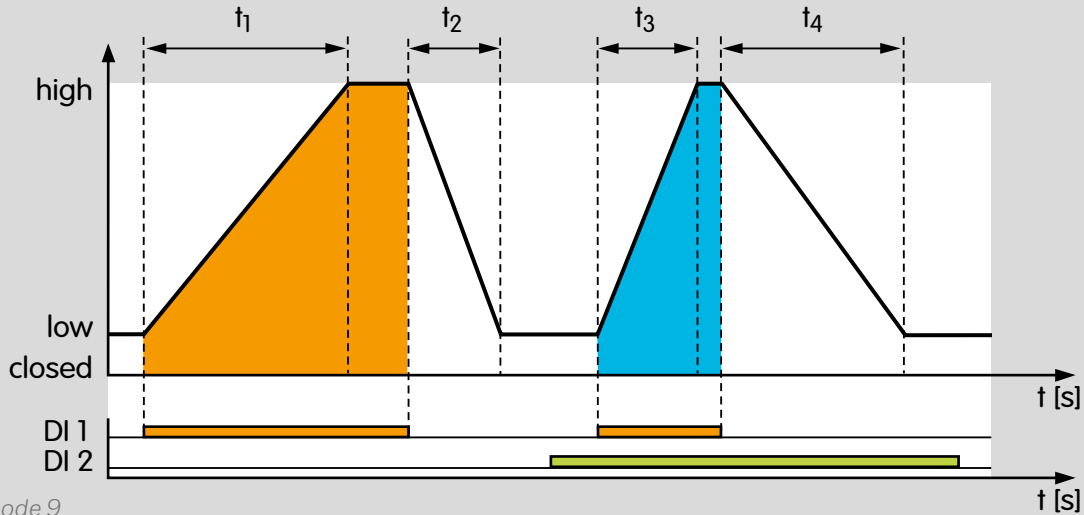

Operating mode 9

3.5.9 2-point operation with switchover of the running times

Operating mode 9

Digital input DI 1 functions as a pulse input.

The actuator operates in high/low (high/closed) intermittent mode via digital input DI 1.

In idle state (DI 1 with no signal), the actuator is in “low” position (“low” position may also be 0° = “closed” position).

DI 1	Position
Off	low/closed
On	high

The running times are switched over via DI 2.

DI 2	Opening time	Closing time
Off	t_1	t_2
On	t_3	t_4

Switchover of the running times may also occur during movement of the actuator.

This function can also be used for fast movement to the pre-purge position, for instance, with correspondingly slow running time for burner operation.

Possible parameter set for this operating mode: P 68025, see page 45 (Parameter sets).

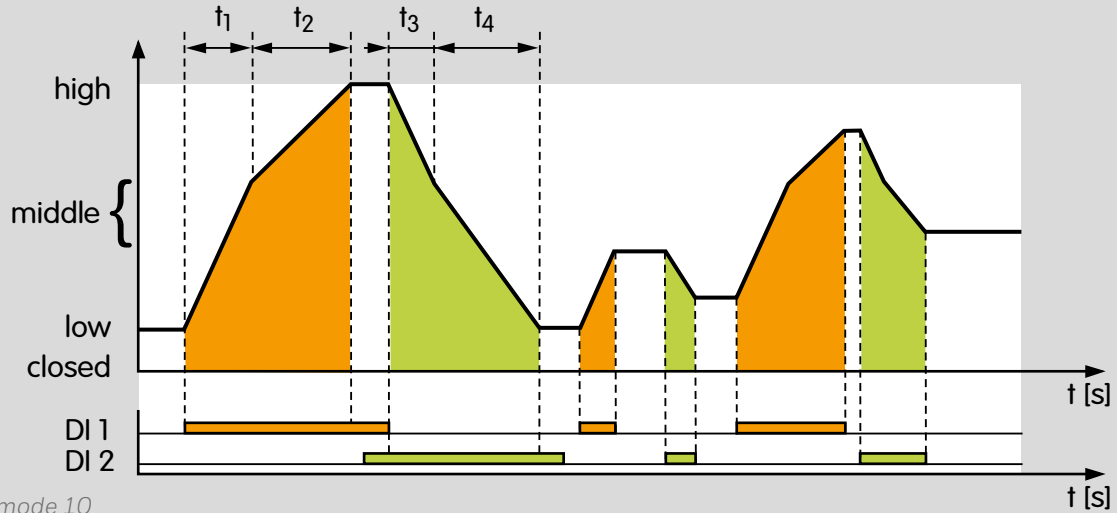

Operating mode 10

3.5.10 3-point step operation with running time fractions

Operating mode 10

If only digital input DI 1 is active, the actuator opens. If only digital input DI 2 is active, the actuator closes.

If neither of the digital inputs or both digital inputs are active simultaneously, the actuator stops in its position. The actuator can be stopped in any position.

The actuator operates in continuous mode and is controlled via a 3-point step signal.

The setting function is limited by the “low” and “high” positions (“low” position may also be 0° = “closed” position).

DI 1	DI 2	Reaction
Off	Off	Idle/Stop
On	Off	Open to “high” position at max.
Off	On	Close to “low” position (“closed” position) at min.
On	On	Idle/Stop

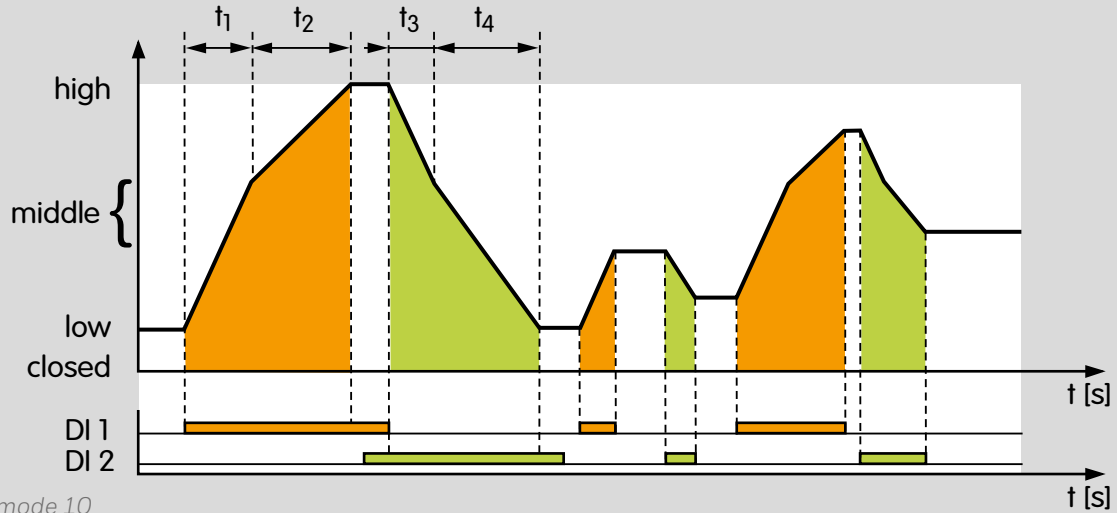

Operating mode 10

The opening time results from the two successive running times t_1 and t_2 .

The closing time results accordingly from running times t_3 and t_4 . "Middle" position is used as an interpolation point. This can be defined individually.

Owing to the two successive running times, the opening characteristic of the butterfly valve can be changed. For example, the characteristic of the air circuit can be adapted to that of the gas circuit.

Running times up to 51 s (2 x 25.5 s) are possible in this operating mode.

Possible parameter sets for this operating mode: P68010, P68011 and P68020, see page 45 (Parameter sets).

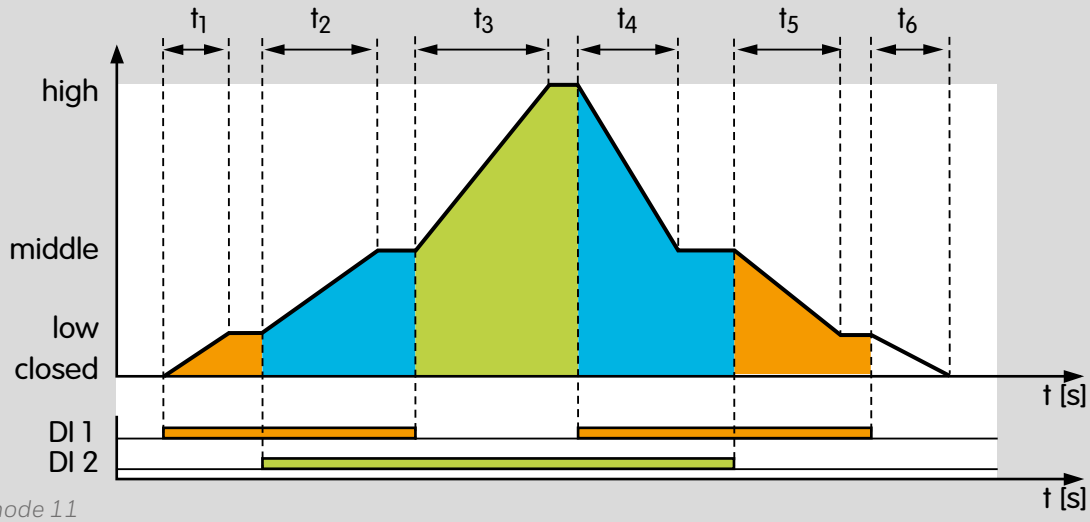

Operating mode 11

3.5.11 3-stage operation with two digital inputs

Operating mode 11

In idle state (DI 1 and DI 2 with no signal), the actuator is in “closed” position and the butterfly valve is closed.

If a signal is applied to DI 1 (DI 2 with no signal), the butterfly valve moves to “low” position (ignition position and low-fire rate position).

If a signal is applied to DI 2 (DI 1 with no signal), the butterfly valve moves to “high” position for pre-purge.

If a signal is applied to DI 1 and DI 2, the butterfly valve moves to “middle” position (high-fire rate).

DI 1/V1	DI 2/air valve	IC 40 Position	Valve position
Off	Off	closed	Closed
On	Off	low	Ignition position/low-fire rate
On	On	middle	High-fire rate
Off	On	high	Pre-purge

Example of application, see page 8 (Staged control with pre-purge).

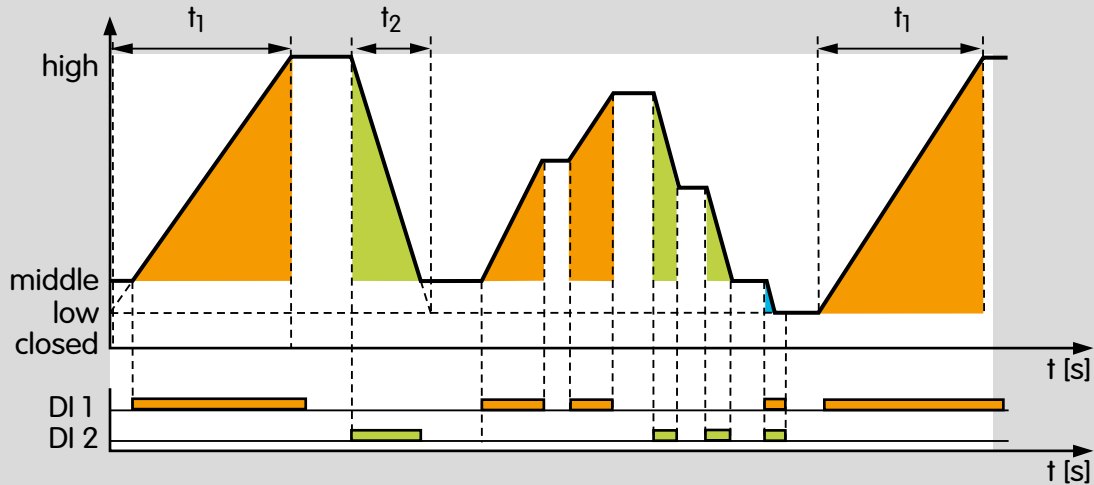

Operating mode 12

3.5.12 3-point step operation with low position

Operating mode 12

If a three-point step signal is applied to DI 1 (DI 2 with no signal), the butterfly valve moves to “high” position.

If a three-point step signal is applied to DI 2 (DI 1 with no signal), the butterfly valve moves to “middle” position.

If no three-point step signal is applied to the inputs (DI 1 and DI 2 with no signal), the actuator stops and the butterfly valve remains in its current position.

If a three-point step signal is applied to inputs DI 1 and DI 2, the actuator moves from the low-fire rate position to “low” position.

DI 1	DI 2	IC 40 position	Valve position
Off	Off	Idle/Stop	Idle
On	Off	Open to high position	Open to high-fire rate
Off	On	Close to middle position	Close to low-fire rate
On	On	low	Valve closes further

Example of application, see page 7 (Continuous control by three-point step signal).

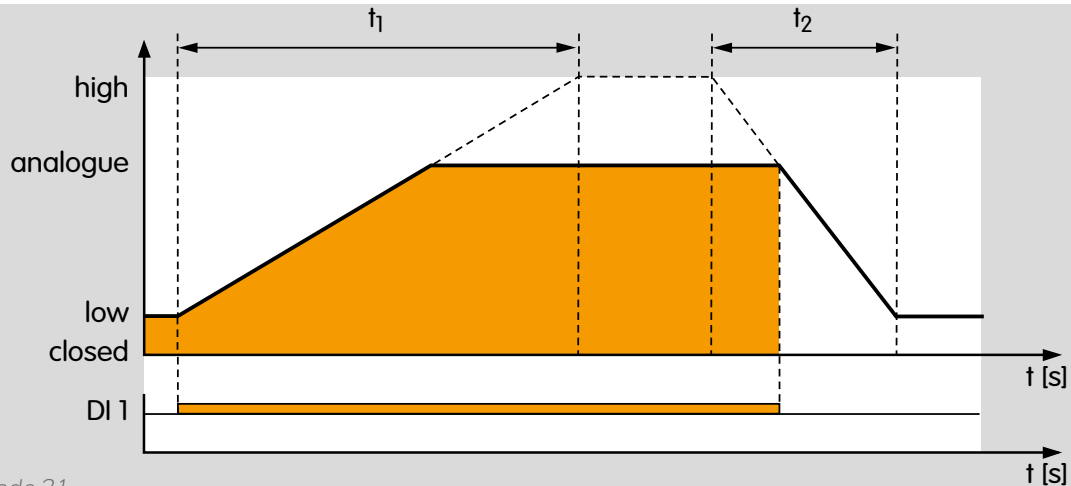

Operating mode 21

3.6 Analogue operating modes 21 – 27

General description, see page 13 (Operating modes).

3.6.1 2-point operation

Operating mode 21

In idle state (DI 1 with no signal), the actuator is in “low” position (“low” position may also be 0° = “closed” position).

If a signal is applied to digital input DI 1, the actuator moves to the position preset via analogue input 4 – 20 mA. When the signal at DI 1 drops, the actuator moves back to “low” position.

The actuator operates in analogue/low (analogue/closed) intermittent mode, whereby the analogue signal determines the adjustment angle for the “open” posi-

tion (= setpoint). The adjustment angle for the “open” position, which can be varied via the analogue signal, is set in BCSofT.

Example: 4 mA for 60% opening and 20 mA for 100% opening. If no analogue value is preset, the actuator remains in “low” position (“closed” position).

DI 1	Position
Off	low/closed
On	analogue

The opening speed is preset via the time t_1 for the entire “low” to “high” setting travel. Accordingly, the closing speed is set with t_2 for the entire “high” to “low” setting travel.

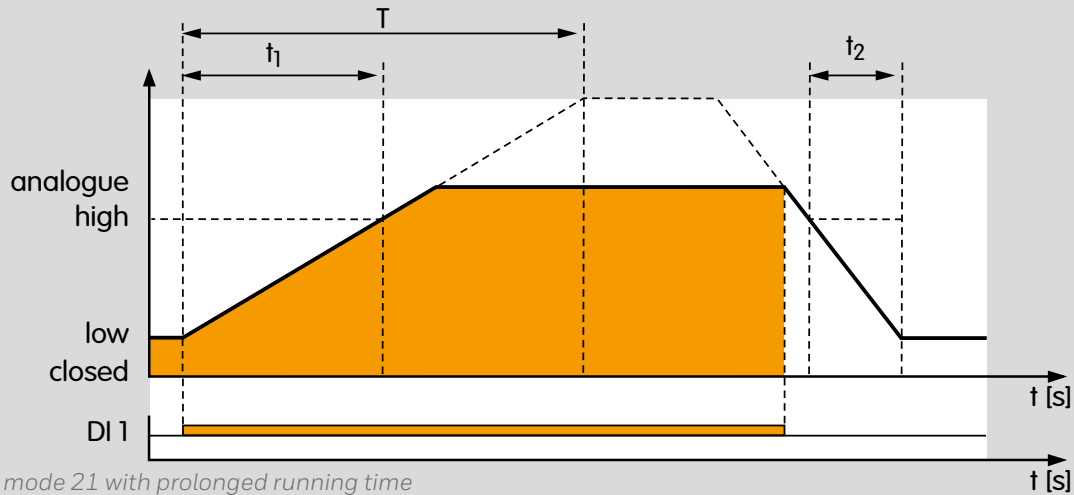

The “high” position can be selected correspondingly lower in order to obtain longer running times (> 25.5 s).
 The “high” position does not limit the adjustment angle for the “open” position but defines only the speeds here.
 Consequently, the “high” position may also be lower than the “analogue” position. The magnitude of the current signal is crucial as regards the “analogue” position.

Example for double running time T:
 The “high” position is set to 50%.

$$T = t_1 \frac{100\%}{\text{high}}$$

$$T = 25.5 \text{ s} \frac{100\%}{50\%}$$

$$T = 51 \text{ s}$$

Possible parameter set for this operating mode:
 P68026, see page 45 (Parameter sets).

Note:

The running time can be prolonged up to max. 150 s for the full adjustment range 0 – 90°. Running times outside of this permitted range are adapted automatically by BCSofT.

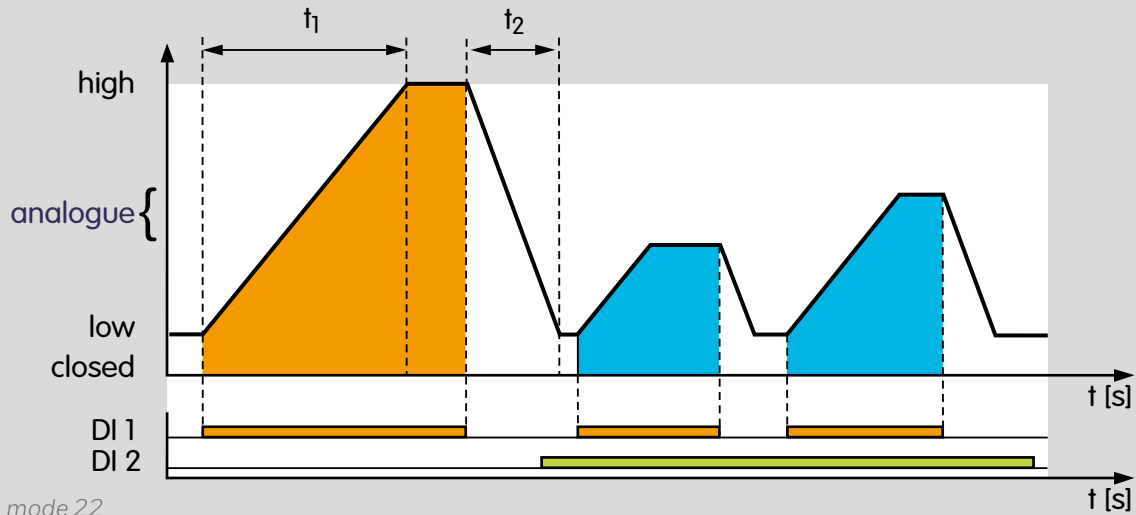

Operating mode 22

3.6.2 2-point operation with switchover of the adjustment angle for the “open” position

Operating mode 22

In idle state (DI 1 and DI 2 with no signal), the actuator is in “low” position independently of the analogue signal (“low” position may also be 0° = “closed” position).

Signal at DI 1, DI 2 with no signal:

The actuator operates in high/low (high/closed) intermittent mode via digital input DI 1.

Digital input DI 1 functions as a pulse input.

Signal at DI 2:

Intermittent mode can switch in ongoing operation between high/low (high/closed) and analogue/low (analogue/closed). The adjustment angle for the “open”

position is then approached with signal at DI 1 and switched over via DI 2. The actuator now operates in analogue/low (analogue/closed) intermittent mode via digital input DI 1.

The adjustment angle for the “open” position, which can be varied via the analogue signal (position setpoint), is set in BCSoft.

Example: 4 mA for 60% opening and 20 mA for 100% opening.

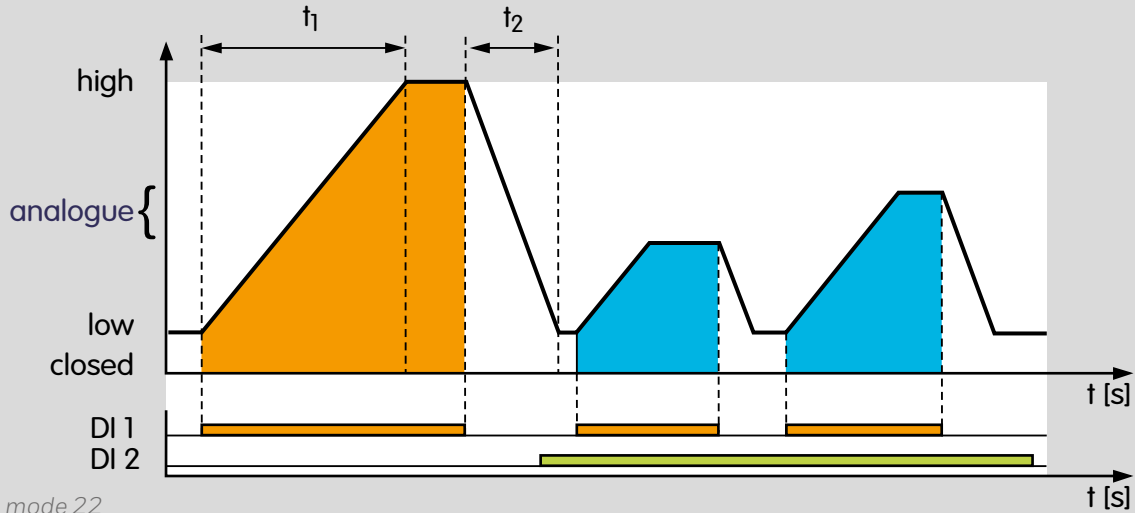

Operating mode 22

Depending on the adjustment angle for the “open” position, the heat output can be reduced and a uniform temperature distribution in the furnace or kiln can be achieved nevertheless owing to intermittent operation of the burner.

DI 1	DI 2	Position
Off	Off	low/closed
On	Off	high
Off	On	low/closed
On	On	analogue

The opening speed is preset via the time t_1 for the entire “low” to “high” setting travel.

Accordingly, the closing speed is set with t_2 for the entire “high” to “low” setting travel.

The speeds are retained in both intermittent modes. The running times are changed accordingly if the “analogue” position (current signal) is moved. The “analogue” position may also be higher than the “high” position in this operating mode.

Possible parameter set for this operating mode: P 68027, see page 45 (Parameter sets).

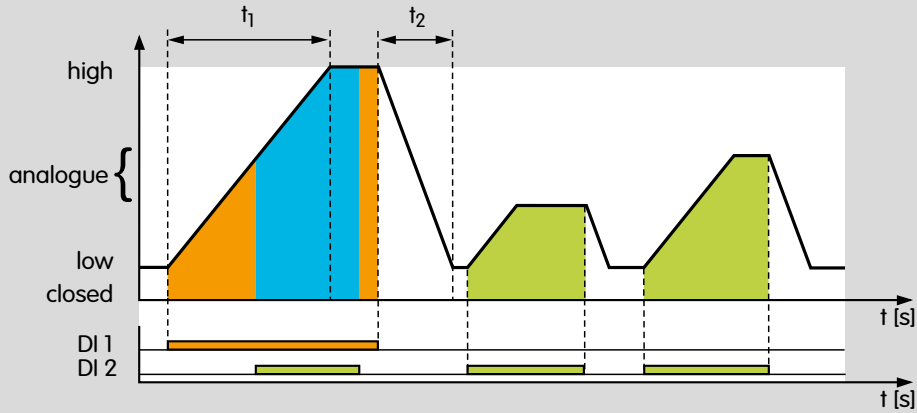

Operating mode 23

3.6.3 2-point operation with input-dependent adjustment angle for the “open” position

Operating mode 23

The function corresponds to operating mode 22 apart from the fact that both digital inputs function as pulse inputs.

The actuator operates in high/low (high/closed) intermittent mode via digital input DI 1.

The actuator operates in analogue/low (analogue/closed) intermittent mode via digital input DI 2.

A signal at DI 1 (priority) always leads to approaching “high” position. This application can be used for purging a furnace or kiln, for instance.

The adjustment angle for the “open” position, which can be varied via the analogue signal, is set in BCSofT.

Example: 4 mA for 60% opening and 20 mA for 100% opening.

Depending on the adjustment angle for the “open” position, the heat output can be reduced and a uniform temperature distribution in the furnace or kiln can be achieved nevertheless owing to intermittent operation of the burner. The “high” position may also be lower than the “analogue” position in this case.

DI 1	DI 2	Position
Off	Off	low/closed
On	Off	high
Off	On	analogue
On	On	high (DI 1 has priority)

Possible parameter set for this operating mode: P68028, see page 45 (Parameter sets).

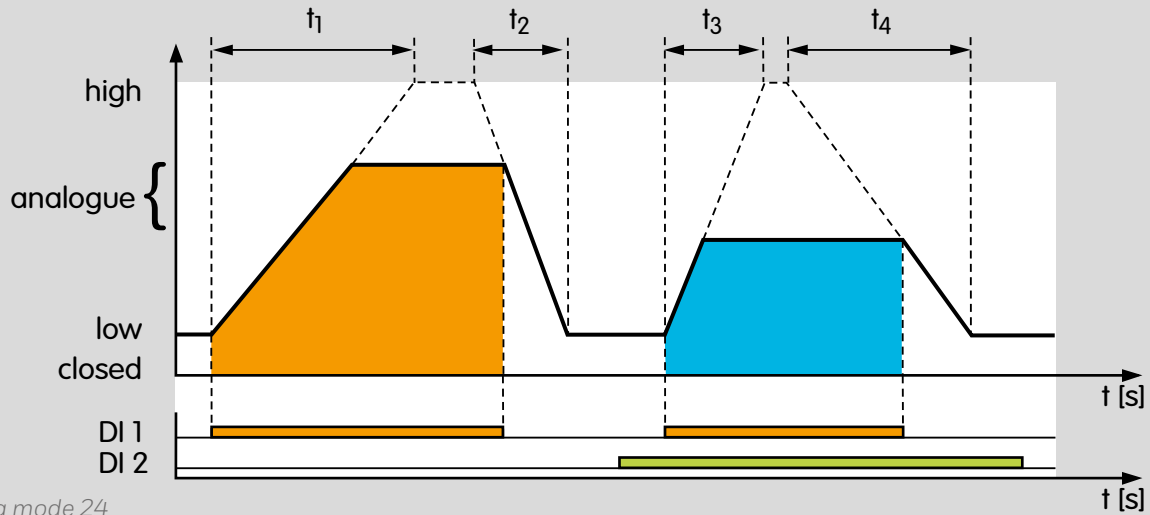

3.6.4 2-point operation with switchover of the running times

Operating mode 24

Digital input DI 1 functions as a pulse input. The actuator operates in analogue/low (analogue/closed) intermittent mode via DI 1.

In idle state (DI 1 with no signal), the actuator is in “low” position (“low” position may also be 0° = “closed” position).

The adjustment angle for the “open” position, which can be varied via the analogue signal, is set in BCSoft.

Example: 4 mA for 60% opening and 20 mA for 100% opening.

Depending on the adjustment angle for the “open” position, the heat output can be reduced and a uniform temperature distribution in the furnace or kiln can be achieved nevertheless owing to intermittent operation of the burner.

DI 1	Position
Off	low/closed
On	analogue

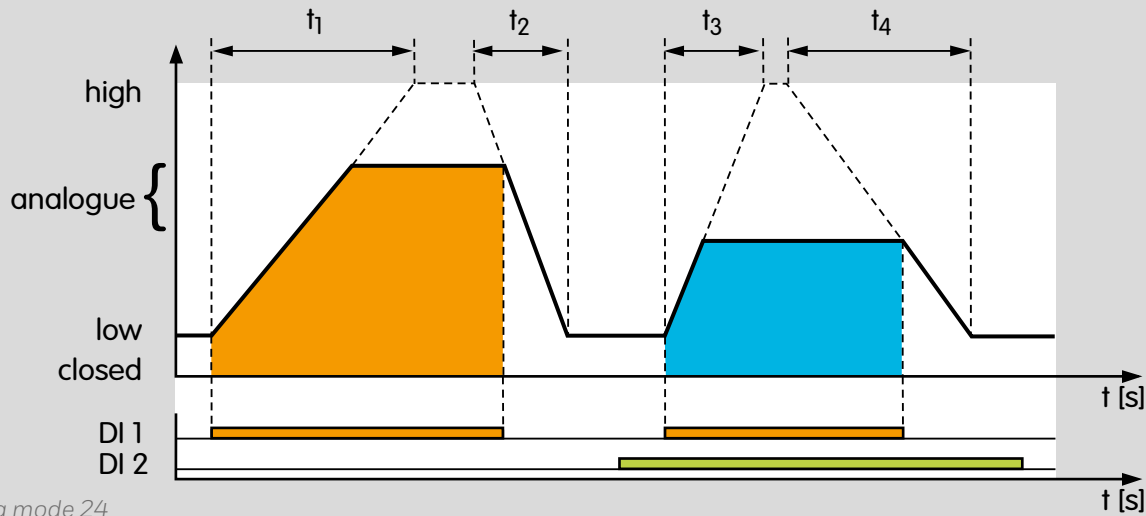

Operating mode 24

The running times are switched over via DI 2.

DI 2	Opening time	Closing time
Off	t_1	t_2
On	t_3	t_4

Possible parameter set for this operating mode: P68029, see page 45 (Parameter sets).

The running times can also be switched over in ongoing operation.

The “high” position can be selected correspondingly lower in order to obtain longer running times (> 25.5 s).

The “high” position does not limit the adjustment angle for the “open” position but only defines the speeds.

Consequently, the “high” position may also be lower than the “analogue” position. The magnitude of the current signal is crucial as regards the “analogue” position.

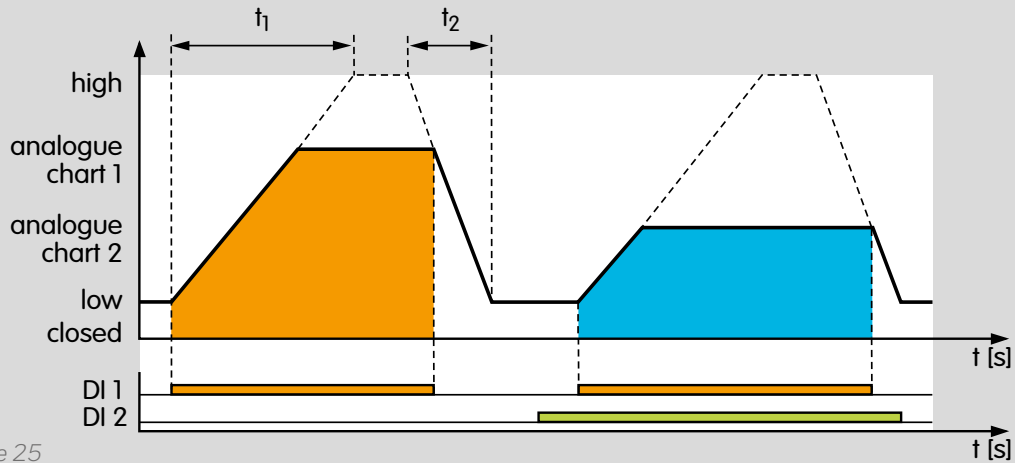

Operating mode 25

3.6.5 2-point operation with characteristic curve switchover I

Operating mode 25

In idle state (DI 1 and DI 2 with no signal), the actuator is in “low” position (“low” position may also be 0° = “closed” position).

DI 1 functions as a pulse input. The analogue characteristic curve (analogue chart 1/analogue chart 2) is switched over via DI 2 and the adjustment angle for the “open” position is preset by this. This angle is approached with signal at DI 1.

DI 2 with no signal:

The actuator operates in analogue chart 1/low (analogue chart 1/closed) intermittent mode via digital input DI 1.

Signal at DI 2:

The actuator operates in analogue chart 2/low (analogue chart 2/closed) intermittent mode via digital input DI 1.

This function allows the actuator to switch over its intermittent mode in ongoing operation. The adjustment angle for the “open” position is preset via two characteristic curves (charts), each with 5 interpolation points, see page 48 (Inputs). This allows the same current signal to be used for running through two different capacity ranges, for example for lambda adjustment or for hot-air compensation.

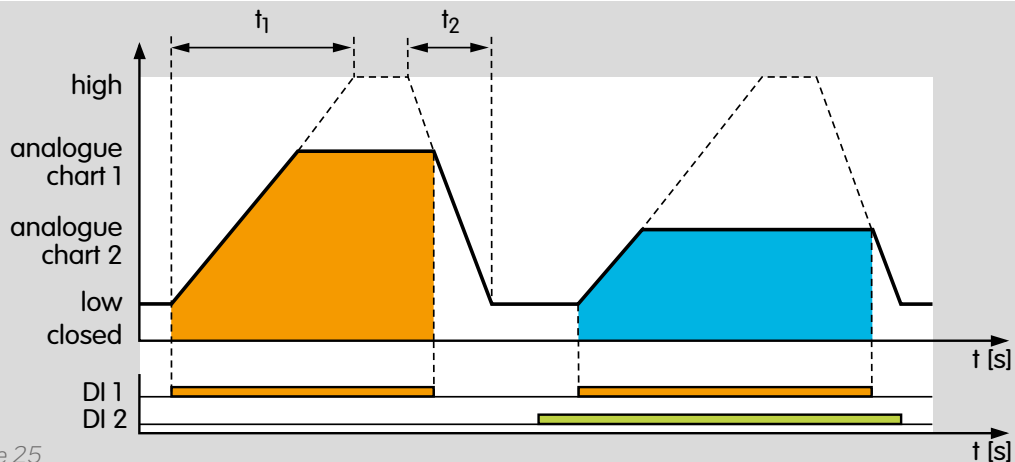

Operating mode 25

The adjustment angles for the “open” position of the characteristic curves chart 1 and chart 2 can be set mutually independently. The adjustment angle for the “open” position of chart 2 may thus also be higher than that of chart 1.

The burner continues to be operated in intermittent mode so as to ensure a uniform temperature distribution even with low heat output.

DI 1	DI 2	Position
Off	Off	low/closed
On	Off	analogue chart 1
Off	On	low/closed
On	On	analogue chart 2

The opening speed is preset via the time t_1 for the entire “low” to “high” setting travel.

Accordingly, the closing speed is set with t_2 for the entire “high” to “low” setting travel.

The speeds are retained in both intermittent modes.

The “high” position can be selected correspondingly lower in order to obtain longer running times (> 25.5 s). The “high” position does not limit the adjustment angle for the “open” position but only defines the speeds. The adjustment angles for the “open” position are preset by the current signal.

Consequently, “high” position may also be lower than the “analogue chart” positions. If no analogue value is preset, the actuator remains in “low” position (“closed” position).

Possible parameter set for this operating mode: P68030, see page 45 (Parameter sets).

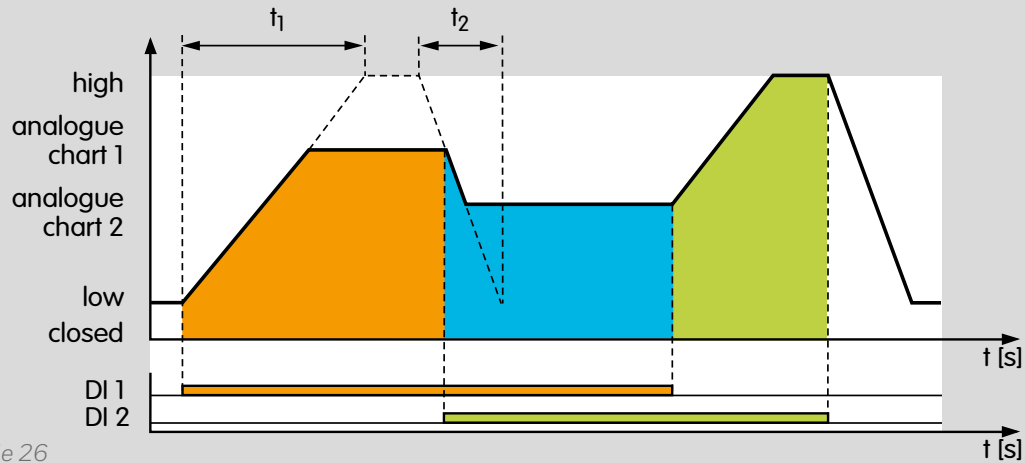

Operating mode 26

3.6.6 2-point operation with characteristic curve switchover II

Operating mode 26

In idle state (DI 1 with no signal), the actuator is in “low” position (“low” position may also be 0° = “closed” position).

Each circuit combination of DI 1 and DI 2 determines precisely one actuator position:

DI 1	DI 2	Position
Off	Off	low/closed
0n	Off	analogue chart 1
Off	0n	high
0n	0n	analogue chart 2

A change in the circuit combination directly triggers approach to the new position.

“High” position may also be lower than the “analogue chart” positions in this case. The opening speed is pre-set via the running time t_1 for the entire “low” to “high” setting travel. Accordingly, the closing speed is set with t_2 for the entire “high” to “low” setting travel. The speeds are independent of the digital inputs and the analogue input in this case.

Two characteristic curves, each with 5 interpolation points, are available, see page 48 (Inputs).

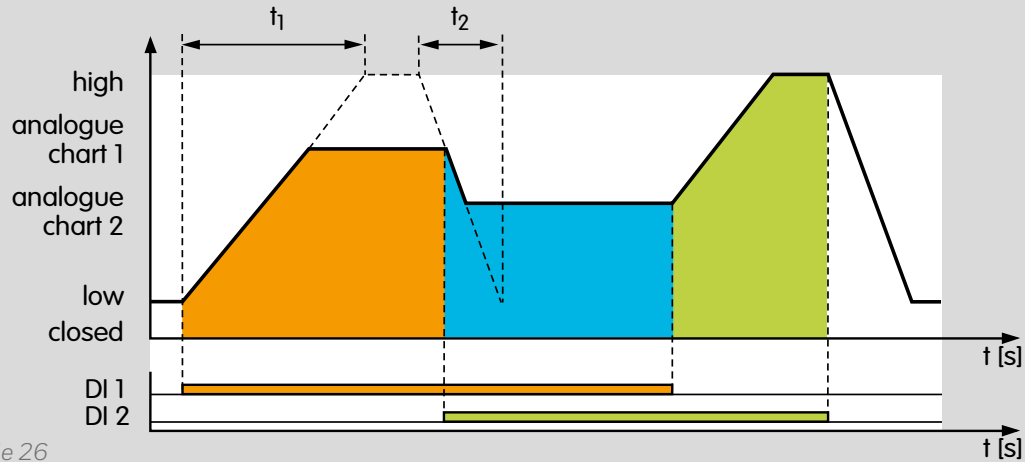

Operating mode 26

This allows the same current signal to be used for running through two different capacity ranges, for example for lambda adjustment or for hot-air compensation.

Intermittent operation

DI 2 with no signal:

The actuator operates in analogue chart 1/low (analogue chart 1/closed) intermittent mode via digital input DI 1.

DI 1 with no signal:

The actuator operates in high/low (high/closed) intermittent mode via digital input DI 2.

DI 1 and DI 2 simultaneously with ON or OFF signal:

The actuator operates in analogue chart 2/low (analogue chart 2/closed) intermittent mode.

If all possible combinations of the two inputs are used, for instance by a PLC control system, this allows high/analogue chart 1/analogue chart 2/low (closed) intermittent mode to be implemented.

Continuous operation

The actuator may also operate in continuous mode via the 4 – 20 mA current input. In this case, it is possible to switch over between two characteristic curves via the digital inputs, see page 48 (Inputs).

As with operating mode 25, this allows lambda adjustment or hot-air compensation to be implemented.

Possible parameter set for this operating mode: P 68031, see page 45 (Parameter sets).

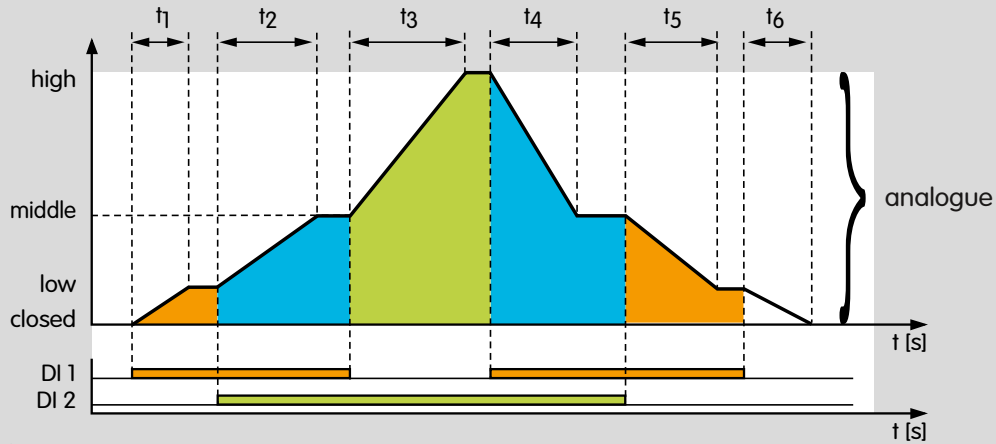

Operating mode 27

3.6.7 2-stage operation with two digital inputs and variable adjustment angle for the “open” position

Operating mode 27

In idle state (DI 1 and DI 2 with no signal), the actuator is in “closed” position and the butterfly valve is closed.

If a signal is applied to DI 1 (DI 2 with no signal), the butterfly valve moves to “low” position (ignition position and low-fire rate position).

If a signal is applied to DI 2 (DI 1 with no signal), the butterfly valve moves to “high” position for pre-purge (high-fire rate).

If a signal is applied to DI 1 and DI 2, the butterfly valve can be moved steplessly via the analogue input. The possible adjustment range is between 0% and 100%. The adjustment angle for the “open” position, which can

be varied via the analogue signal, is set in BCSof. Example: 4 mA for 60% opening and 20 mA for 100% opening.

DI 1	DI 2	IC 40 position	Valve position
Off	Off	closed	Closed
On	Off	low	Ignition position/low-fire rate
On	On	analogue chart 1	In acc. with chart 1
Off	On	high	Pre-purge/high-fire rate

Example of application, see page 9 (Continuous control with defined ignition position).

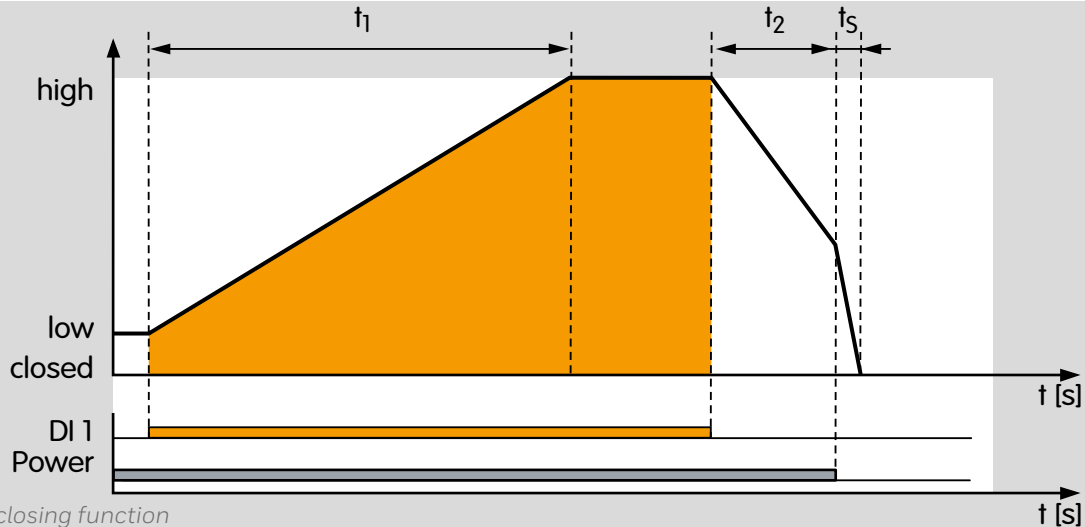

Emergency closing function

3.6.8 Emergency closing function

The emergency closing function cuts in in the event of a fault or interruption of the continuous supply voltage (power) or, for instance, in the event of a motor defect.

A pre-tensioned spiral spring turns the drive shaft with valve disc to the “closed” position within the closing time $t_S < 1$ s.

Fast and reliable closing prevents air being able to flow into the furnace or kiln chamber in uncontrolled manner if the installation is disconnected from the electrical power supply or in the event of a device defect. The penetration of air may also lead to damage to the material in the furnace or kiln in extreme cases, besides changing the furnace or kiln atmosphere.

In order to maximize the service life of the parts subject to wear in the actuator and in the butterfly valve, the emergency closing function should be used only for the intended closing function and not for controlled shut-down or for intermittent switching of the burner.

The emergency closing function is available as an option on the actuator IC 40S and can be implemented only in combination with the butterfly valve BVHS. Both actuator and butterfly valve must feature this function, see page 59 (Selection).

3.7 Parameters

Various parameter sets are saved in the BCSoft software to assist programming. Selecting a parameter set preselects the corresponding operating mode and assigns practical values to all parameters which can be set. Each parameter can be tailored to the individual requirements of the installation

3.7.1 Parameter sets

Parameter set	Operating mode	Function
P68001	6	3-stage operation with one or two digital inputs, running time: 6 s
P68010	10	3-point step operation with running time fractions, running time: 51 s
P68011	10	3-point step operation with running time fractions, running time: 30 s
P68012	5	3-point step operation, running time: 15 s
P68013	5	3-point step operation, running time: 7.5 s
P68014	5	3-point step operation, running time: 4.5 s
P68015	3	2-stage operation with one or two digital inputs, running time: 51 s
P68016	3	2-stage operation with one or two digital inputs, running time: 30 s
P68017	1	2-point operation, running time: 15 s
P68018	1	2-point operation, running time: 7.5 s
P68019	1	2-point operation, running time: 4.5 s
P68020	10	3-point step operation with running time fractions, running time: 15 s
P68021	2	2-point operation with flame proving period, running time: 4.5 s
P68022	4	2-stage operation with two digital inputs, running time: 5 s
P68023	7	2-point operation with switchover of the adjustment angle for the "open" position, running time: 4.5 s
P68024	8	2-point operation with input-dependent adjustment angle for the "open" position, running time: 4.5 s

Function

Parameter set	Operating mode	Function
P68025	9	2-point operation with switchover of the running times, running time: 4.5 s/15 s
P68026	21	2-point operation, running time: 7.5 s
P68027	22	2-point operation with switchover of the adjustment angle for the "open" position, running time: 7.5 s
P68028	23	2-point operation with input-dependent adjustment angle for the "open" position, running time: 7.5 s
P68029	24	2-point operation with switchover of the running times, running time: 4.5 s/15 s
P68030	25	2-point operation with characteristic curve switchover I, running time: 7.5 s
P68031	26	2-point operation with characteristic curve switchover II, running time: 7.5 s

3.7.2 Factory default parameters

Factory default parameters are data saved permanently in the unit. This includes motor data and calibration data.

In addition, information on which parameter set was preset in the condition as delivered is also saved in the factory default parameters, see page 45 (Parameter sets).

3.8 Inputs

3.8.1 Digital

In the basic setting, the two digital inputs operate as universal inputs. If a voltage of 24 V DC or 100 – 230 V AC is applied to the input, this is recognized as “On” signal (positive logic).

Switching logic

The switching logic can be inverted for each individual digital input. An applied voltage is then recognized as “Off” signal while no voltage results in an “On” signal (negative logic). Inversion of the input switching logic in conjunction with the operating modes provides new options for defining the behaviour of the actuator.

3.8.2 Analogue

The actuator can approach corresponding intermediate positions via a current signal to the additional input. This function can be used only if an actuator IC 40 with 4 – 20 mA analogue input is connected (option). The switch-on and switch-off threshold of the analogue input is defined at approx. 3 mA.

The assignment of current value to position can be freely defined via 5 pairs of values (interpolation points).

Each of the interpolation points at 4, 8, 12, 16 and 20 mA can be assigned a position which the actuator approaches when the corresponding current signal is applied. The position is interpolated on the basis of a linear function in each case between the interpolation points.

In the case of operating modes 25 and 26, 2 characteristic curves, each with 5 interpolation points, can be defined. In this case, the digital inputs define which characteristic curve currently applies. This allows the same current signal to be used to run through two different capacity ranges, for example for lambda adjustment or for hot-air compensation, see page 38 (2-point operation with characteristic curve switchover I) and page 40 (2-point operation with characteristic curve switchover II).

Filtering and hysteresis of the current signal

In order to suppress noise of the current signal, the analogue input is sampled equidistantly every millisecond and a mean value is generated over 0.1 s. This filtering can be prolonged up to 1 s in the case of a very poor input signal. However, this also prolongs the response time to a change at the analogue input.

The current input (4 – 20 mA) operates internally with a resolution of 10 bit (corresponding to 0.1% of the actuator). This allows the analogue input to detect a change of 0.02 mA (hysteresis).

If the input signal fluctuates too greatly (owing to noise, for instance), this high resolution results in constant corrections of the actuator and butterfly valve (when mounted onto butterfly valve BV..).

Consequently, the hysteresis may be increased to up to 0.2 mA. The resolution in this case is reduced down to 1% of the actuator accordingly. The maximum resolution is always set in each case as the basic setting.

Priority and running time in operating modes 1 – 10

In operating modes 1 to 10, the actuator is positioned (0 – 100%) by both digital inputs DI 1 and DI 2. Alternatively, on the IC 40A..A, there is the option of positioning the actuator with a 4 – 20 mA current signal. Simultaneous presets via the analogue input and via the digital inputs necessitate defining a priority in BCSofT. The digital inputs have priority by default.

Opening speeds and closing speeds between 0 and 25.5 s can be set for analogue mode. The time always relates to the distance between the positions at 4 and 20 mA. If the current signal changes more slowly than the set running time, the actuator follows more slowly accordingly through to step-by-step movement, see page 14 (Running times).

3.9 Outputs

Various, independent signalling functions can be assigned to the two outputs RO 1 and RO 2: closed position, low position, middle position and high position, fault signals and freely programmable positions.

2 relays with change-over contacts are available for signalling. The contacts are floating and are thus referred to as dry contacts. They can be integrated in automation processes.

For instance, reaching the preset position can be signalled back as a signal function. The range in which the output switches can be defined in BCSoft using the relational operator. The range may be $=$, \geq or \leq the set position. Thus, for instance, the behaviour of a cam disk can be simulated.

Example for output 1 (RO 1): if the condition is met, the output relay is energized. Terminals 10 and 12 are connected, see page 53 (Connection diagram).

The switching range can also be set individually via one minimum value and one maximum value. These settings are independent of the selected low position, middle position or high position.

A feedback signal can also be used as a fault signal. In BCSoft, it is possible to select what status is to lead to setting of the output (relay energized).

Device defective:

An internal error, such as a fault in the memory chip, leads to failure of the device.

Internal warning (reference switch):

Internal monitoring of the motor position has detected a fault. Recalibrate!

Internal temperature $> 90^{\circ}\text{C}$:

Warning! Attach heat deflectors.

Service note:

Number of cycles, changes of direction or relay switching operations greater than limit.

“Fault signals” also covers a “Device in Manual mode” signal even though the signal is not actually a fault signal.

The precise cause of the signal is displayed in BCSoft and saved in the statistics, see page 52 (Statistics).

The feedback signal of the IC 40 must not be used on its own for fail-safe signalling of a status or a fail-safe position, see page 60 (Project planning information).

3.10 Manual mode

For simplified commissioning, the actuator can be operated “by hand” via the BCSofT software. Manual mode is activated via BCSofT.

A distinction is made between two types of Manual mode: **Direct position preset** and **Simulate inputs**. The related setting options are enabled after the required Manual mode is selected.

The exterior, applied input signals have no effect on the control element in both Manual operating modes. Instead, the device responds to the presets from the software.

Fast flashing of the blue LED indicates that the actuator is in Manual mode.

Only one Manual mode may be activated at any one time. If the Manual mode is to be changed, the existing Manual mode must first be deactivated before the other Manual mode can be activated.

3.10.1 Direct position preset

This Manual mode serves to determine the operating positions for the process, such as the low-fire rate (low) position, the ignition (middle) position and the high-fire rate (high) position.

For this purpose, the actuator can be moved to any position, regardless of the input signal. The position can be entered or changed directly in BCSofT. The resolu-

tion is defined in ranges fine/medium/coarse, whereby “fine” allows any step of the step motor (< 0.05%).

After transfer of the values from BCSofT to the actuator, the actuator responds accordingly to the new presets. The new position is always approached at maximum speed in this case.

The operating position determined can be assigned in BCSofT to a position, for example ignition position.

3.10.2 Simulate inputs

When this Manual mode is activated, the external inputs are deactivated. Instead, the signals of the two digital inputs can be preset “manually”. If the actuator has a 4 – 20 mA analogue input (option), this can also be simulated.

Switching the inputs allows the behaviour of the actuator to be tested. This allows the set running times to be checked and optimized in BCSofT.

3.11 Statistics

The statistical data stored in the unit, such as fault signals which have occurred, various counter readings and measured values, is displayed in statistics in BCSofT.

The **counters** and **measured values** ranges are each split into overall data and customer data. The customer data is used for recording information over a specific period.

3.11.1 Counters

Actuating cycles (0 – 100 – 0%), changes of direction (Open/Close), switching of the output relays, “Power On” switching operations and mains operating hours are added in the statistics. Besides the total counters, there are customer counters for recording information over a specific period.

3.11.2 Measured values

The minimum and maximum internal housing temperatures are saved in statistics. In addition, the current internal temperature is displayed. Here as well, there is a customer memory for viewing a period.

3.11.3 Resetting statistics

All signals and customer data can be reset. The reset date is saved automatically and displayed together with the customer data.

Total counter and measured values cannot be reset or deleted.

3.11.4 Resetting a signal

A fault signal is signalled by the red LED on the actuator. The detailed cause of the signal is displayed in BCSofT. The cause must be remedied. The signal can then be acknowledged and reset with BCSofT.

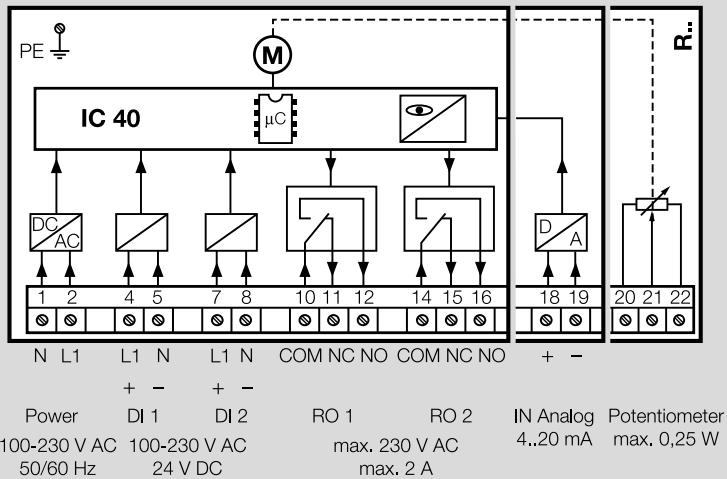

3.12 Connection diagram

For detailed information on the electrical connections, see page 60 (Project planning information). or on the technical data, see page 66 (Technical data).

3.13 Display

3.13.1 During operation

Blue LED	Red LED	Operating state
Moderately flashing ²⁾	Off	Zero position
Slow flashing ³⁾	Slow flashing ³⁾	Calibration
Lit	Off	Device in Standby mode
Moderately flashing ²⁾	Off	Device in motion
Fast flashing ¹⁾	Off	Manual mode
Fast flashing ¹⁾	Off	Moving in Manual mode
Lit	Flashing depending on fault message	Fault
Flashing alternately for 2 s ¹⁾		Parameters accepted

¹⁾ Fast: 5 times per second, ²⁾ moderately: 3 times per second, ³⁾ slow: once per second

3.13.2 Warnings and faults

Blue LED	Red LED	BCSoft fault code	Warning/fault	Description	Cause
According to operating state	Flashing light (1×)	1	Warning	Internal temperature > 90°C	- High ambient temperature
According to operating state	Flashing light (2×)	4	Warning	Drift > 5%	- Mechanical valve offset - Valve moving against its stop
According to operating state	Flashing light (3×)	7	Warning	Drift > 10%	- Mechanical valve offset - Valve moving against its stop
According to operating state	Flashing light (4×)	8	Warning	Reference switch does not open	- Valve blocked - Large mechanical offset - Internal error - Actuator offset
According to operating state	Flashing light (5×)	9	Warning	Reference switch does not close	- Valve blocked - Internal error - Actuator offset, mechanical offset
According to operating state	Flashing light (6×)	10	Warning	Analogue input IN < 4 mA	- Signal interrupted - Signal not connected - Input defective

Function

Blue LED	Red LED	BCSoft fault code	Warning/fault	Description	Cause
According to operating state	Flashing light (7×)	21	Warning	Service note: number of OPEN/CLOSE cycles > limit value	
According to operating state	Flashing light (8×)	22	Warning	Service note: number of changes of direction > limit value	
According to operating state	Flashing light (9×)	23	Warning	Service note: number of relay output RO 1 or RO 2 switching operations > limit value	
Flashing light (1×)	Permanent light	5	Fault	Internal fault	- e.g. EEPROM reading or writing error
Flashing light (2×)	Permanent light	11	Fault	Zero position check: reference switch does not close	- Valve blocked - Internal error - Actuator offset - Valve not closed (BVHS)
Flashing light (3×)	Permanent light	12	Fault	Zero position check: reference switch does not open	- Valve blocked - Internal error - Actuator offset
Flashing light (6×)	Permanent light	30	Fault	Saving error for adjustable parameters, etc.	
Flashing light (7×)	Permanent light	31	Fault	Saving error: factory default parameters	
Flashing light (8×)	Permanent light	32	Fault	Saving error: user calibration	
Flashing light (9×)	Permanent light	15	Fault	Low voltage	Check actuator mains voltage supply

3.14 Relay outputs RO 1 and RO 2 function

The function of digital outputs RO 1 and RO 2 can be adjusted using BCSofT.

Signal at RO 1 or RO 2	Further setting options	Remarks
CLOSED position	equal to = greater than or equal to > = equal to or less than < =	
Low-fire rate position (low)		
Intermediate position (middle)		
OPEN position (high)		
Freely programmable position	Minimum and maximum value [°, %]	Relay switches when valve between min. and max. position
Faults and warnings	Reference switch drift > 5% ¹⁾ Reference switch drift > 10% ¹⁾ Reference switch does not open ¹⁾ Reference switch does not close ¹⁾ Internal temperature > 90°C Analogue input IN < 4 mA Service note	Faults are always signalled, warnings are signalled depending on the selection in BCSofT (see Inputs/Outputs, 54 (Warnings and faults))
Fault		Only faults are displayed
Manual mode		Device is in Manual mode
Ready		Relay drops out in the event of: faults (not in the event of warnings), Manual mode, zero position check, calibration, no mains voltage
None		Relay output has no function

¹⁾ These warnings are displayed as positioning errors in BCSofT.

4 Replacement possibilities for actuators

4.1 GT 31 is to be replaced with IC 40

GT 31	Actuator	Actuator	IC 40
03	Running time [s/90°]: 3.7 s		●
07	7.5 s		●
15	15 s	Running time: 4.5 – 76.5 [s/90°] ³⁾	●
30	30 s		●
60	60 s		●
H	Mains voltage: 24 V AC	-	-
M	120 V AC	Mains voltage ⁴⁾ : 100 – 230 V AC, ±10%	A
T	220/240 V AC		A
1	Torque: 1.2 Nm	-	-
2	Torque: 2.5 Nm	Torque: 2.5: Nm ²⁾	2
3	Torque: 3.0 Nm	Torque: 3.0: Nm ²⁾	3
●	Three-point step control	Three-point step control ³⁾	D
R	Two-point step control	Two-point step control ³⁾	D
E	Continuous control	4 – 20 mA analogue input	A
G	Additional switches with gold contacts	-	-
○ ¹⁾	1000 Ω feedback potentiometer	1000 Ω feedback potentiometer	R10

Example

GT 31-07T2E

Example

IC 40A2A

with parameterset P68013³⁾

● standard, ○ available

¹⁾ See separate type label on the device

²⁾ IC 40: 2.5 Nm, IC 40S: 3.0 Nm.

³⁾ Various parameter sets can be preset ex-works.

⁴⁾ Supply the IC 40 permanently with voltage

4.2 M 5/M 6 is to be replaced with IC 40

M	Solenoid actuator	Actuator	IC 40
●	Closed when de-energized	Emergency closing function	S
5	Actuator size 5 for DN 40 – 80	–	–
6	Actuator size 6 for DN 100	–	–
R	Slow opening, slow closing		
L	Slow opening, quick closing	Running time: 4.5 – 76.5 [s/90°] ¹⁾	●
N	Quick opening, quick closing		
T	Mains voltage: 220/240 V AC	Mains voltage ²⁾ : 100 – 230 V AC, ±10%	A
M	110 V AC	100 – 230 V AC, ±10%	A
K	24 V DC	–	–
●	Two-point control	Two-point control ¹⁾	●
3	Terminal connection box, IP 54	IP 65	●
6	... Standard plug	–	–

Example

M 6RT3

Example

IC 40SA

with parameter set P68019¹⁾

● standard, ○ available

¹⁾ Various parameter sets can be preset ex-works.

²⁾ Supply the IC 40 permanently with voltage.

5 Selection

5.1 Selection table

	S ²⁾	A	2 ³⁾	3 ³⁾	A ⁴⁾	D ⁴⁾	R10
IC 40 ¹⁾	○	●	●	●	○	●	○

- 1) Please quote the required parameter set in your order.
Running time programmable between 4.5 and 76.5 s.
- 2) Only in conjunction with butterfly valve BVHS. If "none", this specification is omitted.
- 3) C 40: 2.5 Nm, IC 40..S: 3.0 Nm.
- 4) If "none", this specification is omitted.

● = standard, ○ = available

Example

IC 40A2D

5.2 Type code

Code	Description
IC 40	Actuator
S	Emergency closing function
A	Mains voltage: 100 – 230 VAC, 50/60 Hz
2 3	Torque: 2.5 Nm 3 Nm
A D	4 – 20 mA analogue input Digital inputs
R10	Feedback potentiometer

6 Project planning information

6.1 Electrical connection

6.1.1 Cable selection

Install supply and signal lines separately.

Cables should be installed well away from high-voltage lines of other devices.

Use temperature-resistant supply cables ($\geq 90^{\circ}\text{C}$ and min. 1 – 1.5 mm² or AWG 14 – 18).

Observe EMC Directive for installation of signal lines.

Do not connect power supply and digital inputs to different phases of a three-phase current system.

6.1.2 Digital inputs

The digital inputs require a current of approx. 5 mA at 24 V DC or approx. 3 mA at 230 V AC. To avoid interference, it may be necessary to increase the output current by using an additional load resistor on the signal sensor.

Load resistors may not be fitted inside the IC 40 for reasons relating to heat dissipation.

Example for 24 V DC and 10 mA:

Load resistor = 4.7 k Ω , 0.6 W.

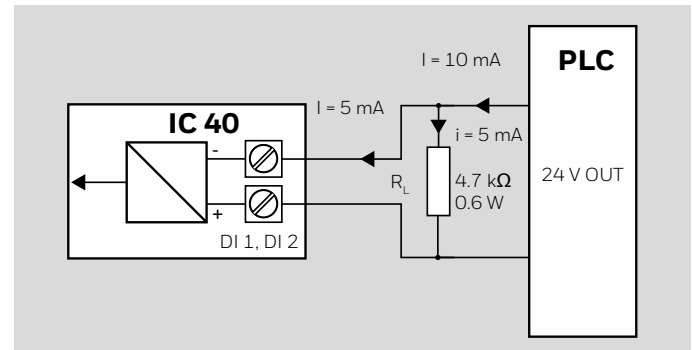

6.1.3 Feedback signalling

The feedback signal function (relay contact) possible with the outputs must not be used on its own for fail-safe signalling of the status or of the position.

Please refer to the relevant Directives and Standards as to whether and when a fail-safe signal is required.

As defined in European Standard EN 746-2 for instance, gating of two non-fail-safe sensors (signals) must be considered as a fail-safe equivalent array if the two sensors detect different physical variables.

Example 1:

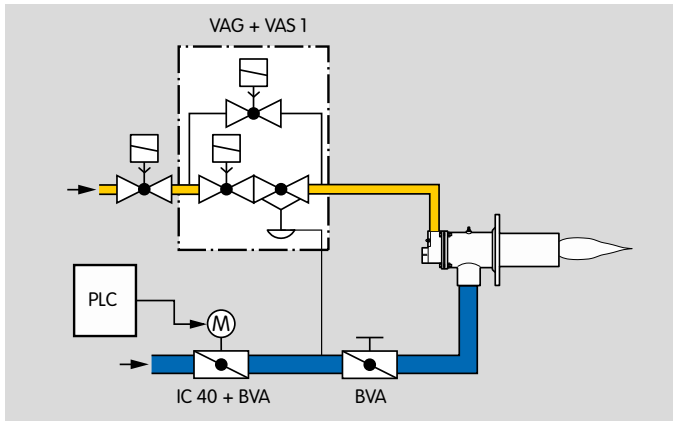

A fail-safe equivalent array for the ignition position of the butterfly valve for air may be series connection of a pressure switch signal with the feedback signal of the IC 40.

In this application, the pressure switch monitors the maximum permitted air pressure so as to restrict the maximum permitted start fuel flow rate using the air/gas ratio control GIK.

Example 2:

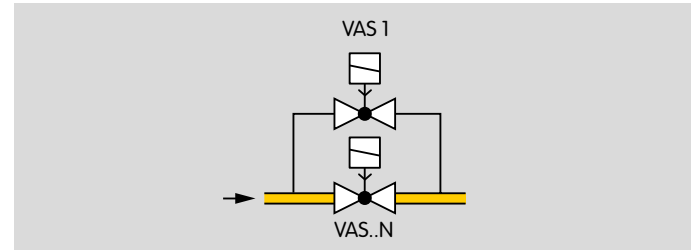

One other option of fail-safe limitation of the start fuel flow rate is utilization of a bypass in the gas circuit. A bypass valve can limit the amount of gas in fail-safe manner owing to its nominal cross-section. The maximum possible gas pressure must be allowed for when selecting the nominal cross-section.

At all events, the plant operator is responsible for assessing installation safety. Elster GmbH can, in this case, only provide its own estimates and resultant recommendations which do not reflect the individual situation of the particular installation.

6.2 Feedback potentiometer

The feedback potentiometer offers the option of monitoring the current position of the actuator.

It must be utilized as a voltage divider. The change in position of the potentiometer wiper (which corresponds to the actuator position) can be measured as a changing voltage between U_- and U_M .

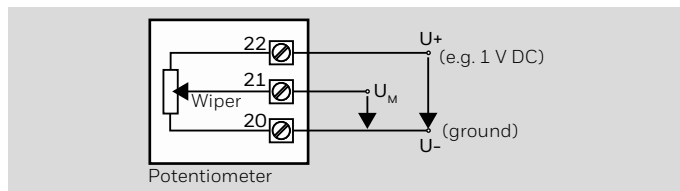

Other circuit layouts produce measurement results that are inaccurate and do not remain stable over a long period of time or are non-reproducible. They also reduce the service life of the feedback potentiometer.

The potentiometer is only suitable for connection of safety extra-low voltage (SELV) and protective extra low voltage (PELV).

IC 40 cannot be retrofitted with a potentiometer. The actuator is available with fitted potentiometer.

6.3 Installation

The IC 40 must not be installed in a public place. It must be accessible to authorized personnel only. Unauthorized personnel could make changes which could cause the system to become unsafe or dangerous.

Installation position: vertical or horizontal, not upside down.

If the actuator is used with hot air, the pipeline should be adequately insulated so as to reduce the ambient temperature.

Important! In order to avoid over-heating, the flanges and butterfly valve must not be insulated.

In conjunction with butterfly valves BVH, BVHS, the actuator can be used in temperatures of up to 250°C, with additional heat deflectors it can be used in temperatures of up to 450°C, see page 64 (Accessories).

In order to mount the actuator onto control elements other than DKL, DKG, BVA, BVAF, BVG, BVGF, BVH, BVHS or VFC, the attachment set for “single application” is required, see page 64 (Accessories).

6.4 Commissioning

When mains power is connected, the actuator IC 40 conducts a zero position check. To do this, the actuator opens the control element to approx. 25°. Then the actuator moves to the position specified by the operating mode and input signals.

7 Accessories

7.1 Heat deflectors

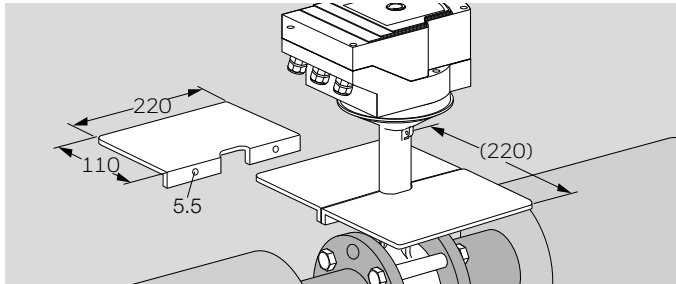

In conjunction with butterfly valves BVH, BVHS for hot air, the actuator can be used in temperatures of up to 250°C, with additional heat deflectors it can be used in temperatures of up to 450°C.

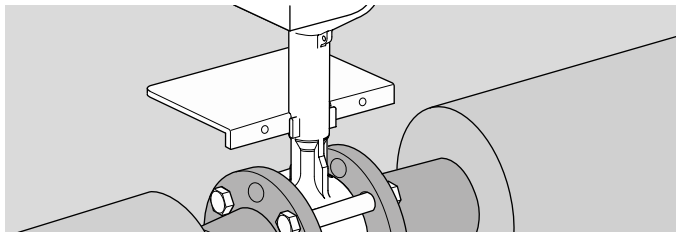

Order No.: 74921670

If you are using an insulated pipeline, ensure that there is sufficient installation space to access the heat deflectors and the screw connectors near the valve.

7.2 “Single application” attachment set

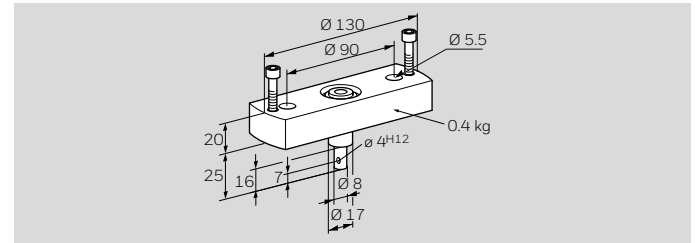

Order No.: 74921671

This attachment set is required if the actuator is mounted onto control elements other than DKL, DKG, BVA, BVAF, BVG, BVGF, BVH, BVHS or VFC.

7.3 BCSoft

The current software can be downloaded from our Internet site at www.docuthek.com. To do so, you need to register in the DOCUTHEK.

7.3.1 Opto-adapter PCO 200



BCSoft CD-ROM included,
Order No.: 74960625.

7.4 Cable gland with pressure equalization element

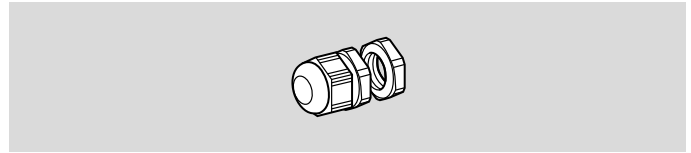

To avoid the formation of condensation, the cable gland with pressure equalization element can be used instead of the standard M20 cable gland. The diaphragm in the gland is designed to ventilate the device, without allowing water to enter.

1 x cable gland, Order No.: 74924686.

8 Technical data

Purpose of control: operating control, electric actuator.

Mains voltage:

100 – 230 V AC, $\pm 10\%$, 50/60 Hz, the actuator automatically adjusts to the respective mains voltage.

Power consumption: 10.5 W/21 VA at 230 V AC,
9 W/16.5 VA at 120 V AC.

Switch-on peak current: max. 10 A for max. 5 ms.

Screw terminals using the elevator principles for cables up to 4 mm² (single core cables) and for cables up to 2.5 mm² with wire end ferrules.

Angle of rotation: 0 – 90°, setting accuracy < 0.05°.

Holding torque = torque as long as mains voltage is applied.

Independently mounted control.

Pollution degree: 3 (outside of enclosure)/
2 (within enclosure).

Rated impulse voltage: 4000 V.

Impedance protected motor.

2 digital inputs:

24 V DC or 100 – 230 V AC each.

Current requirement of digital inputs:

24 V DC: approx. 5 mA eff,

230 V AC: approx. 3 mA eff.

1 analogue input (optional):

4 – 20 mA (load impedance switchable from 50 Ω to 250 Ω).

Potentiometer (optional): 1 k Ω \pm 20%, see page 62 (Feedback potentiometer).

Linearity tolerance: \pm 2%, max. capacity: 0.25 W, conductive plastic element.

Tap wiper at high resistance.

2 digital outputs:

Signalling contacts designed as relay change-over contacts. Contact current of digital outputs: min. 5 mA (resistive) and max. 2 A (resistive).

Enclosure:

IC 40: IP 64, in conjunction with BVH: IP 65,
IC 40: Nema 2, in conjunction with BVG, BVA or
BVH: Nema 3.

Safety class: I.

Duty cycle: 100%.

Type of action to EN 60730: type 1C.

Software class A.

Overvoltage category III.

Electrical connection: line entrance: 3 x M20 plastic cable glands.

Ambient temperature:

-20 to +60°C, no condensation permitted.

Storage temperature: -20 to +40°C.

Max. installation altitude: 2000 m AMSL.

8.1 Running times and torques

Type	Running time [s/90°]		Torque [Nm]	
	50 Hz	60 Hz	50 Hz	60 Hz
IC 40	4.5 - 76.5	4.5 - 76.5	2.5	2.5
IC 40S	4.5 - 76.5	4.5 - 76.5	3	3

On the IC 40, the running time and torque are independent of the mains frequency. The running time can be freely programmed between the limits of 4.5 – 76.5 s.

The following specifications on the designed lifetime of the actuator relate to typical applications with BVA, BVAF, BVG, BVGF, BVH, BVHS and VFC.

Mechanical switching cycles

(0° – 90° – 0°/0% – 100% – 0%):

IC 40 with VFC: 5 million cycles

IC 40 with BVA/BVG: 5 million cycles

IC 40 with BVAF/BVGF: 5 million cycles

IC 40 with BVH/BVHx: 3 million cycles

Typical number of operating cycles of the digital outputs RO 1 and RO 2:

Switching current	Switching cycles
5 mA	4,000,000
2A	250,000

8.2 Dimensions

8.2.1 IC 40

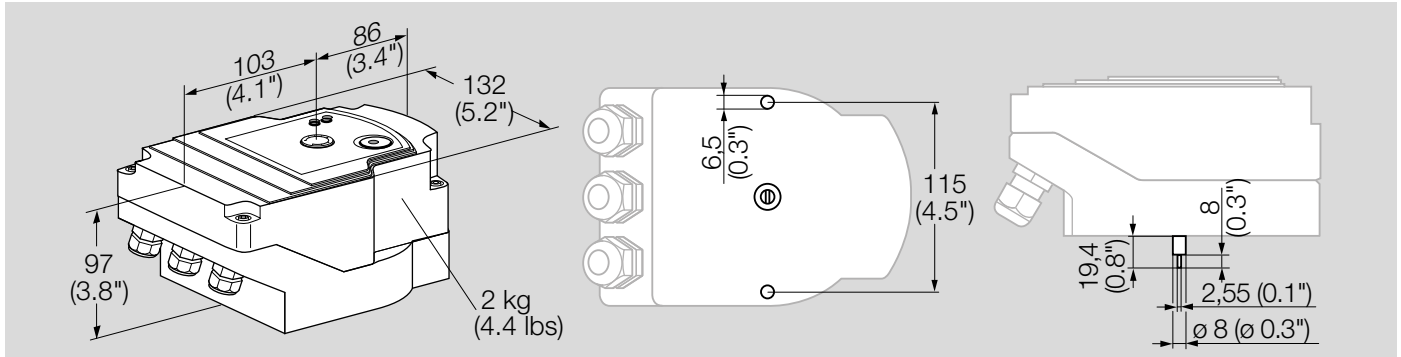

Other dimensions of IC 40 with butterfly valves BV., see www.docuthek.com, Butterfly valves BVG, BVA, BVH, Technical Information. Dimensions of IC 40 with VFC, see www.docuthek.com, Linear flow controls VFC, Technical Information.

9 Maintenance cycles

Actuator IC 40 suffers little wear and requires little servicing.

We recommend a function check once a year.

If the “Service note” option has been activated in BCSofT, the warning limits are preset as follows and can be adapted if necessary:

3 million cycles (0 – 90 – 0°/0 – 100 – 0%),

3 million relay switching operations,

5 million changes of direction.

10 Glossary

10.1 Start fuel flow rate

The start fuel flow rate is the quantity of fuel ignited by the ignition device on start-up of the burner.

10.2 Positions

Position is the angle (0 – 90° or 0 – 100%) which the actuator approaches. There are 4 positions, depending on the set operating mode:

Closed = 0° = 0%,

Low = low-fire rate,















Middle = intermediate,

High = open.

10.3 Adjustment angle for the “open” position

The adjustment angle for the “open” position indicates the approached position of the actuator and thus determines the maximum quantity in intermittent mode.

11 Legend

	Manual mode
	Safety interlocks (limits)
	Start-up signal
	High temperature mode
	Ignition transformer
	Gas valve
	Air valve
	Purge
	Ext. air valve control
	Flame signal
	Operating signal
1, 2	Pilot and main burner
	Fault signal
	Reset
t_s	Closing time
	Air pressure switch

Feedback

Finally, we are offering you the opportunity to assess this “Technical Information (TI)” and to give us your opinion, so that we can improve our documents further and suit them to your needs.

Clarity

- Found information quickly
- Searched for a long time
- Didn't find information
- What is missing?
- No answer

Comprehension

- Coherent
- Too complicated
- No answer

Scope

- Too little
- Sufficient
- Too wide
- No answer



Use

- To get to know the product
- To choose a product
- Planning
- To look for information

Navigation

- I can find my way around
- I got “lost”
- No answer

My scope of functions

- Technical department
- Sales
- No answer

Remarks

Contact

Elster GmbH
Postfach 2809 · 49018 Osnabrück
Strotheweg 1 · 49504 Lotte (Büren)
Germany

Tel. +49 541 1214-0
Fax +49 541 1214-370
hts.lotte@honeywell.com
www.kromschroeder.com

The current addresses of our international agents are available on the Internet:
www.kromschroeder.de/Weltweit.20.0.html?&L=1

We reserve the right to make technical modifications in the interests of progress.
Copyright © 2018 Elster GmbH
All rights reserved.

